



目录	页面	Contents	Page
----	----	----------	------

**YS系列斜齿-蜗杆减速机**

**YS Series Helical-worm Gear Motor**

产品外形	367-367	Products Figure	367-367
型号标记	368-368	Designation	368-368
电机配置说明	368-369	Configuration	368-369
安装位置	370-371	Mounting Position	370-371
技术参数	372-402	Technical Data	372-402
安装尺寸	403-432	Mounting Dimensions	403-432

YS系列结构图

YS series structrue drawing

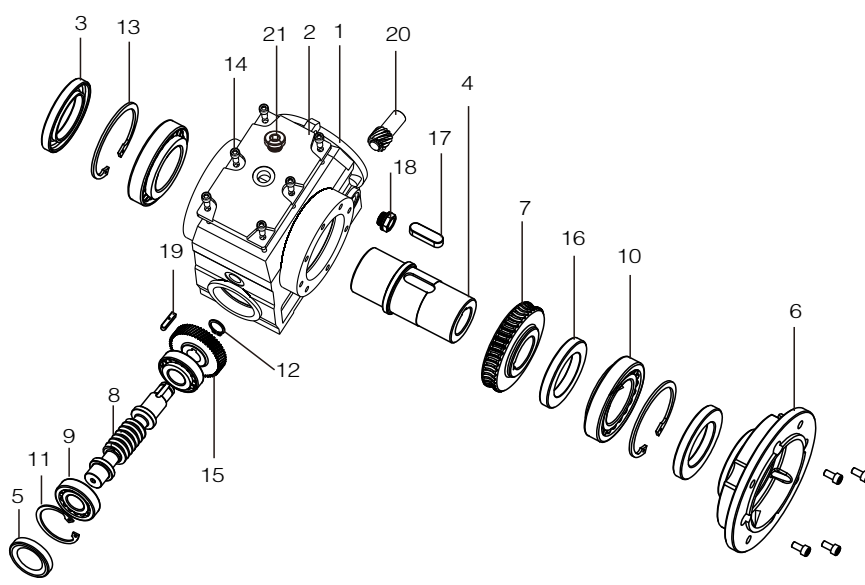

- 1.箱体 Housing
- 2.箱盖 Cover plate
- 3.油封 Circlip for hole
- 4.输出轴 Output shaft
- 5.封盖 Grand
- 6.输出法兰 Output flange
- 7.蜗轮 Worm wheel
- 8.蜗杆 Worm
- 9.轴承 Bearing
- 10.轴承 Bearing
- 11.孔用挡圈 Circlip for hole
- 12.轴用挡圈 Circlip for shaft
- 13.孔用挡圈 Circlip for hole
- 14.螺钉 Screw
- 15.一级大齿轮 First-stage big gear
- 16.垫圈 Washer
- 17.平键 Key
- 18.油镜, 油塞 Oil gauge Oil plug
- 19.平键 Key
- 20.输入齿轴 Input gear shaft
- 21.通气帽 Breather



产品外形

Products Figure

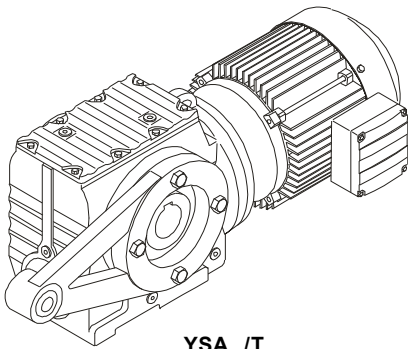

YSA.../T

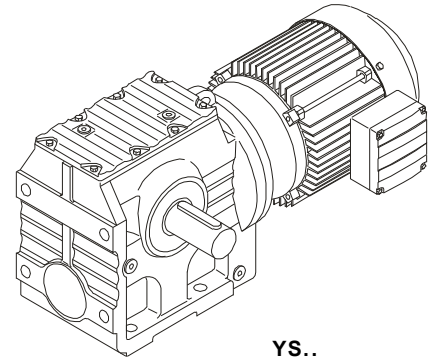

YS..

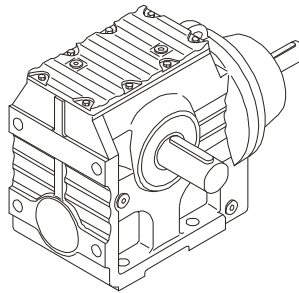

YS..S

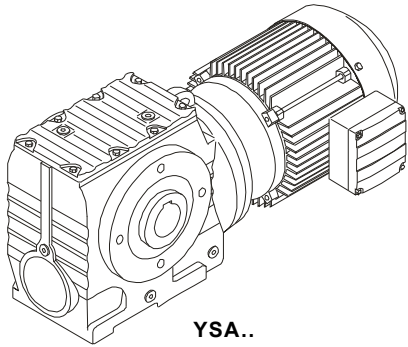

YSA..

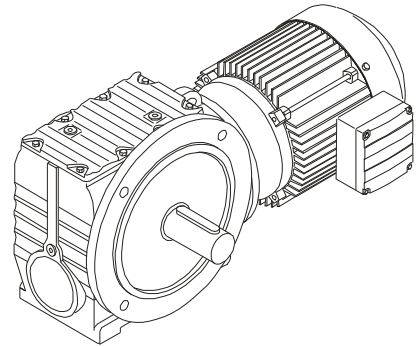

YSF..

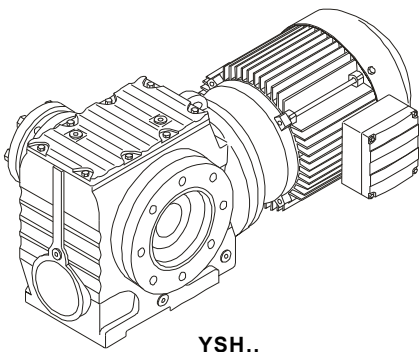

YSH..

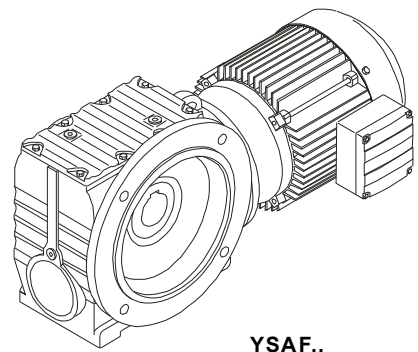

YSAF..

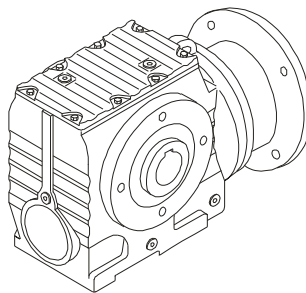

YS..B5

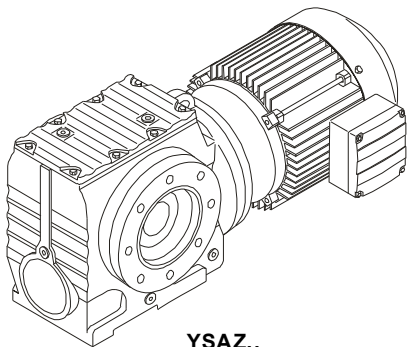

YSAZ..

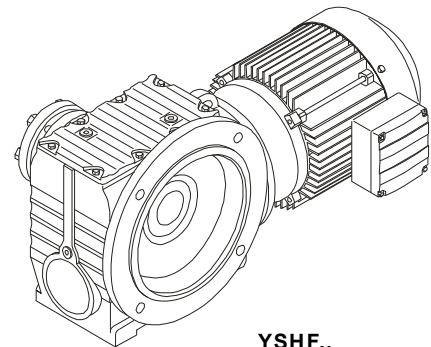

YSHF..



## 型号标记



### 标记示例

- A YSA57Y100L1-4NA194M1-270 (Ø35)**  
空心孔Ø35输出, 轴装式, 机型号57, 电机规格Y100L1-4, 输出转速194rpm, 安装位置M1, 电机接线盒位置270°
- B YSA57BY100L1-4NA194M1-270 (Ø30)**  
空心孔Ø30输出, 底脚安装, 机型号57, 电机规格Y100L1-4, 输出转速194rpm, 安装位置M1, 电机接线盒位置270°
- C YSHF57YB100L1-4NA194M1A-270 (dII BT4, IP54/F Ø 35)**  
法兰安装, 空心孔Ø35带胀紧套输出, 机型号57, 防爆电机YB100L1-4 防爆等级dII BT4, 防护等级IP54, 绝缘等级F, 输出转速194rpm, 安装位置M1, 输出发兰方向A, 电机接线盒位置270°

## 电机配置说明

### Y系列普通三相异步电机

- 1 本系列减速机标准配置Y系列普通三相异步感应电机;
- 2 电机电压: 380V/50Hz;
- 3 电机防护等级IP54, 绝缘等级F, B级温升;
- 4 环境温度不超过40℃, 不低于-15℃;
- 5 连续工作制S1;
- 6 海拔高度不超过1000m;

## Designation

- gear unit type
- YS** : solid shaft, foot-mounted
  - YSF** : solid shaft, flange-mounted
  - YSA** : hollow shaft with key, shaft-mounted
  - YSAF** : hollow shaft with key, flange-mounted
  - YSH..** : with shrink disk
  - YS..Z** : small flange mounting
  - YSA..B** : hollow shaft with key, foot-mounted
- gear unit size
- input structure:
- connect with motor, indicate motor model
  - connect with IEC flange, indicate frame
- output speed
- connect with motor, indicate output speed
  - connect with IEC flange or with input shaft, indicate ratio
- mounting position
- output shaft and flange position
- terminal box position

### Sign Example

- A YSA57Y100L1-4NA194M1-270 (Ø 35)**  
hollow shaft Ø 35, shaft mounted with, gear unit size 57, motor frame Y100L1-4, output speed 194 rpm, mounting position M1, terminal box 270°
- B YSA57BY100L1-4NA194M1-270 (Ø 30)**  
foot mounted, hollow shaft Ø 30, gear unit size 57, motor frame Y100L1-4, output speed 194 rpm, mounting position M1, terminal box 270°
- C YSHF57YB100L1-4NA194M1-270 (dII BT4, IP54/F Ø 35)**  
flange mounted, hollow shaft Ø 35 with shrink disc, gear unit size 57, explosion proof motor frame 100L1-4, protection IP54/F, output speed 194 rpm, mounting position M1, output flange position A, terminal box 270°

## Configuration of Electric Motor

### Y series Three-phase Asynchronous Electric Motor

- 1 this series gear unit configure three-phase asynchronous electric motor;
- 2 voltage: 380V/50Hz;
- 3 protection class: IP54, insulation class: F; temperature rising class: B;
- 4 ambient temperature: -15~40℃ ;
- 5 continue working duty: S1;
- 6 altitude less than 1000m;



## 电机配置说明

## Configuration of Electric Motor

### Y系列普通三相异步电机

- 冷却方式为C0141（风扇自冷）；
- 100L2及以下规格为"Y"接法，112M及以上规格为"Δ"接法；
- 优先选用4, 6, 8极电机，2极电机不推荐使用；
- 电机技术参数见第433-438页

### YEJ系列三相异步制动电机

- 三相异步制动电机为普通电机的基础上附加制动器；
- 电机电压：380V/50Hz；
- 制动器电压：规格71~100: DC99V  
规格112~200: DC170V
- 配置单相AC220/50Hz整流器；
- 电机防护等级IP44，绝缘等级F, B级温升；
- 环境温度不超过40℃,不低于-15℃；
- 连续工作制S1；
- 海拔高度不超过1000m；
- 冷却方式为C0141（风扇自冷）；
- 100及以下规格为"Y"接法，112M及以上规格为"Δ"接法；
- 优先选用4, 6, 8极电机，2极电机不推荐使用。
- 电机技术参数见第433-438页

### YVF系列三相异步变频电机

- 电机电压：380V；
- 基准频率：50Hz；
- 允许调频5~50Hz，恒转矩调速；
- 电机防护等级IP54，绝缘等级F, B级温升；
- 环境温度不超过40℃,不低于-15℃；
- 连续工作制S1；
- 海拔高度不超过1000m；
- 冷却方式为C416（独立风扇）；
- 接线方式按适配变频器要求；
- 优先选用4极电机。

### 特殊电机

- 选用包括防爆电机，辊道电机，船用电机，多速电机等特殊电机，  
本公司提供IEC标准电机法兰接口，接口尺寸见431页；
- 异频率，异电压电机，请联系本公司技术部；
- 使用环境温度不在-15~40℃范围内，请联系本公司技术部；
- 更高的绝缘等级及防护等级，请联系本公司技术部。

### Y series Three-phase Asynchronous Electric Motor

- self-cooling with fan:C0141；
- within frame 100, follow connection Y, from frame 112, follow connection Δ；
- first select 4,6,8 poles motor；
- technical data on page 433-438.

### YEJ series Three-phase Asynchronous Brake Motor

- base on Y series motor, add a brake.
- voltage:380V/50Hz；
- brake voltage: frame:71~100 DC99V  
frame:112~200 DC170V；
- with single phase AC220V/50Hz rectifier；
- protection class:IP54,insulation class: F, temperature rising class: B；
- ambient temperature:-15~40℃；
- continue working duty:S1；
- altitude less than 1000m；
- self-cooling with fan:C0141；
- within frame 100, follow connection Y, from frame 112, follow connection Δ；
- first select 4,6,8 poles motor；
- technical data on page 433-438.

### YVF series Three-phase Variable-frequency Motor

- voltage:380V；
- rated frequency 50Hz；
- available frequency:5~50Hz；
- protection class:IP54,insulation class: F, temperature rising class:B；
- ambient temperature:-15~40℃；
- continue working duty:S1；
- altitude less than 1000m；
- cooling with independence fan:C416；
- connection perform the requirement of inverter；
- first select 4 poles motor；

### Customized Motor

- others like explosion proof, roller motor, marine motor or multi-speed motor coupled by adaptor, the dimensions on page 431.
- need different frequency and voltage, please contact us.
- ambient temperature is not in -15~40℃, please contact us.
- for higher insulation and protection class, please contact us.



安装位置

Mounting Position

YS,YSAZ,YSHZ型减速机安装位置

YS,YSAZ,YSHZ type Gear Unit Mounting Position

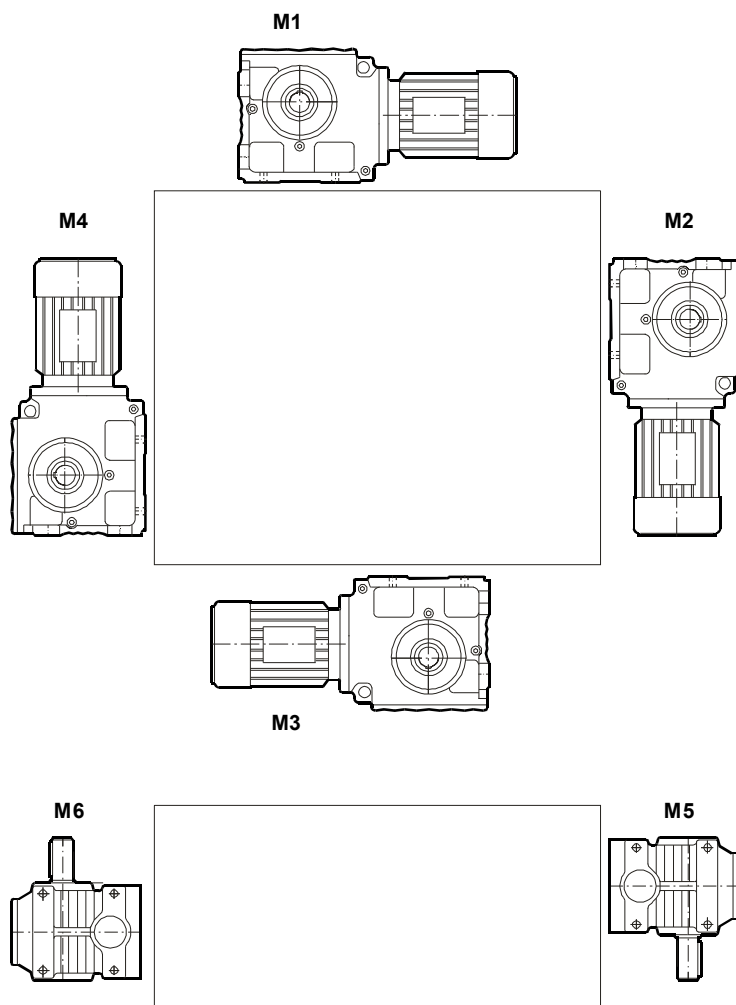

输出轴方向

Output Shaft Position

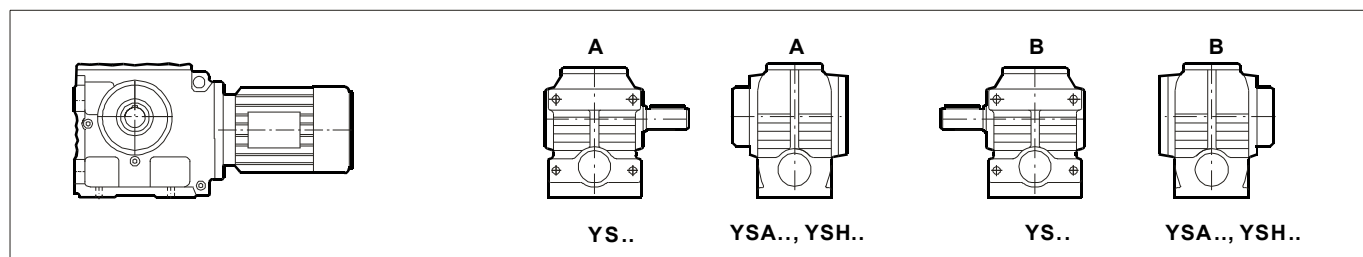

接线盒位置

Terminal Box Position

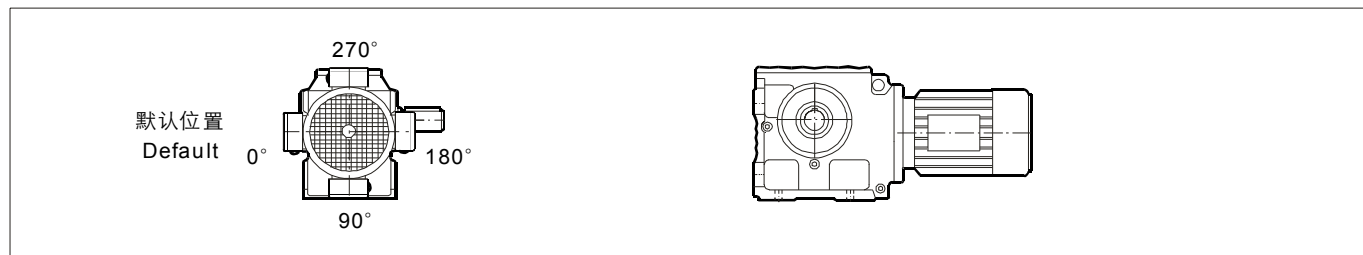



安装位置

Mounting Position

YSF, YSAF, YSHF 减速机安装位置

YSF, YSAF, YSHF type Gear Unit Mounting Position

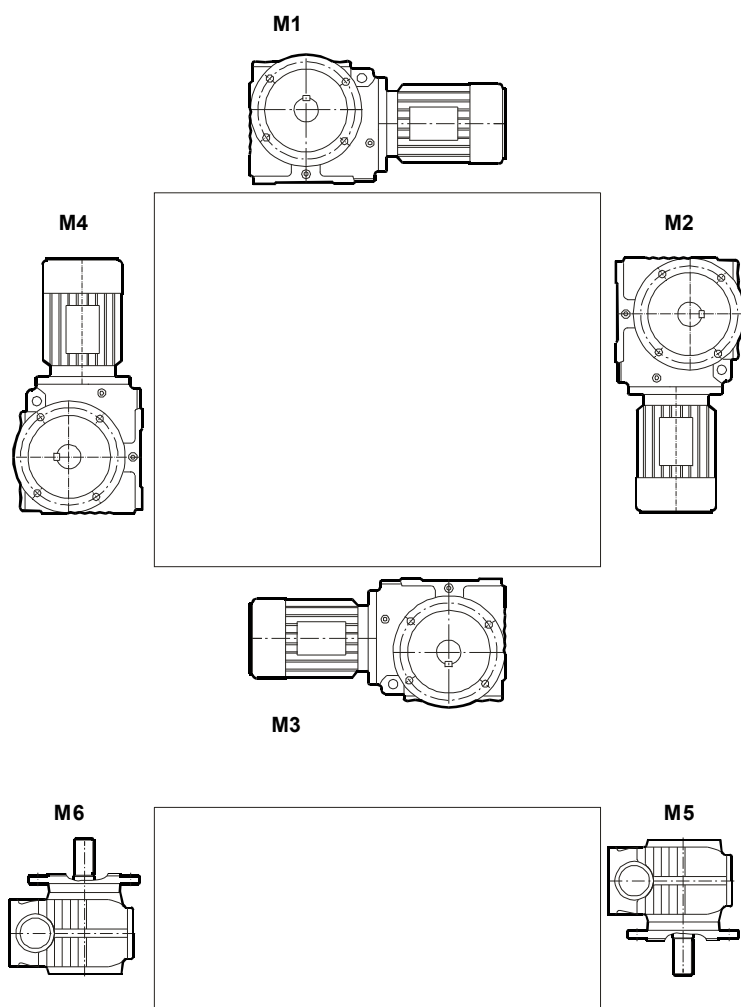

输出轴方向

Output Shaft Position

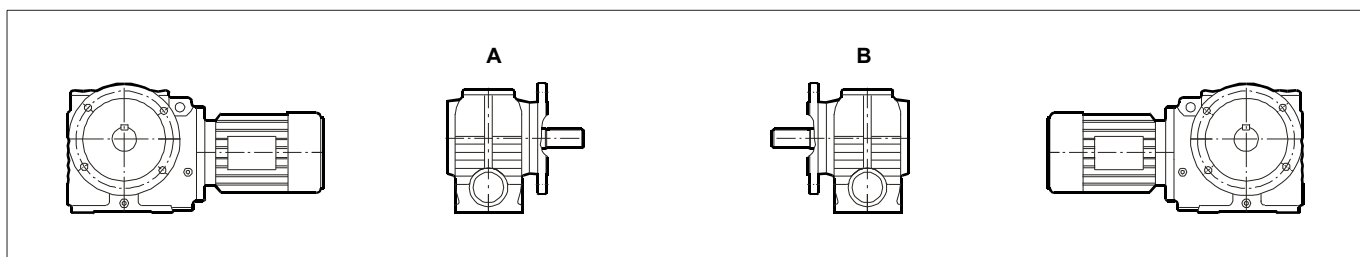

接线盒位置

Terminal Box Position

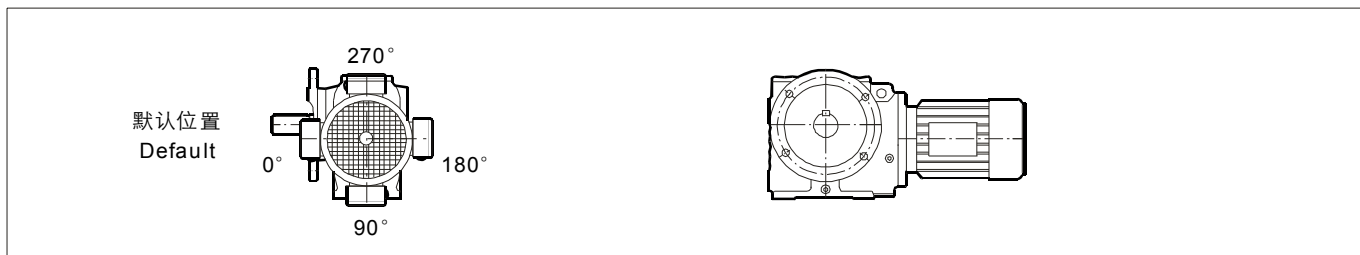



**技术参数**

**Technical Data**

符号意义

Key to Symbols

①  
↓

**$P_1 = 0.12 \text{ kW}$**

<b>NA</b> rpm	<b>M<sub>2</sub></b> Nm	<b>i</b>	<b>Fr<sub>2MAX</sub></b> [N]	<b>f<sub>s</sub></b>	<b>Type</b>	<b>Gear unit</b>	<b>Motor size</b>	 Kg
0.12	4750	11267	25100	0.90	YS	97 YR57	63M1-4	170
0.14	4340	10078	32500	0.95	YSF	97 YR57	63M1-4	200
0.16	3600	8608	34000	1.15	YSA	97 YR57	63M1-4	165
0.18	3180	7554	34700	1.30	YSAF	97 YR57	63M1-4	190

↑      ↑      ↑      ↑      ↑      ↑      ↑      ↑      ↑  
 ②      ③      ④      ⑤      ⑥      ⑦      ⑧      ⑨      ⑩

- 1 电机功率
- 2 输出转速
- 3 输出转矩
- 4 减速比
- 5 输出轴中最大点载荷
- 6 使用系数
- 7 减速机类型
- 8 减速机规格
- 9 电机型号
- 10 大概重量

- 1 motor power
- 2 output speed
- 3 output torque
- 4 transmission ratio
- 5 maximum load on middle output shaft
- 6 service factor
- 7 gear unit type
- 8 gear unit size
- 9 motor frame
- 10 approximate weight



技术参数

Technical Data

P <sub>1</sub> = 0.12 kW								
N <sub>A</sub> rpm	M <sub>2</sub> Nm	i	Fr <sub>2</sub> MAX[N]	f <sub>s</sub>	Type	Gear unit	Motor size	 Kg
0.12	4750	11267	25100	0.90	YS	97 YR57	63M1-4	170
0.14	4340	10078	32500	0.95	YSF	97 YR57	63M1-4	200
0.16	3600	8608	34000	1.15	YSA	97 YR57	63M1-4	165
0.18	3180	7554	34700	1.30	YSAF	97 YR57	63M1-4	190
0.21	2690	6706	27100	0.95	YS	87 YR57	63M1-4	110
0.23	2400	5875	27700	1.05	YSF	87 YR57	63M1-4	130
0.27	1990	5187	28500	1.25	YSA	87 YR57	63M1-4	105
0.30	1770	4606	28800	1.40	YSAF	87 YR57	63M1-4	120
0.36	1470	3872	29200	1.70				
0.39	1370	3540	7240	0.90				
0.45	1200	3098	12300	1.05				
0.58	1330	2374	10600	0.95	YS	77 YR37	63M1-4	59
0.66	1170	2083	12600	1.05	YSF	77 YR37	63M1-4	68
0.76	990	1813	13900	1.25	YSA	77 YR37	63M1-4	58
0.79	940	1745	14200	1.30	YSAF	77 YR37	63M1-4	65
0.86	860	1600	14600	1.45				
0.98	755	1404	15100	1.65				
1.1	660	1245	15500	1.90				
1.2	590	1194	7990	0.95	YS	67 YR37	63M1-4	39
1.3	530	1045	8560	1.05	YSF	67 YR37	63M1-4	46
1.5	460	914	9180	1.25	YSA	67 YR37	63M1-4	40
					YSAF	67 YR37	63M1-4	45
1.7	420	809	9460	1.35				
1.9	370	712	9780	1.55	YS	67 YR37	63M1-4	39
2.2	305	615	10100	1.85	YSF	67 YR37	63M1-4	46
2.5	275	543	10200	2.1	YSA	67 YR37	63M1-4	40
2.9	225	469	10400	2.5	YSAF	67 YR37	63M1-4	45
3.3	205	424	10500	2.8				
3.8	187	365	10500	3.0				
2.1	330	655	6800	0.90				
2.4	285	574	7200	1.05				
2.7	250	506	7480	1.20	YS	57 YR17	63M1-4	20
3.1	215	438	7700	1.40	YSF	57 YR17	63M1-4	24
3.6	189	388	7850	1.60	YSA	57 YR17	63M1-4	20
4.1	169	336	7950	1.80	YSAF	57 YR17	63M1-4	23
4.7	145	294	8050	2.1				
5.1	139	269	8070	2.2				
3.1	215	438	5010	0.85				
3.6	189	388	5170	1.00	YS	47 YR17	63M1-4	17
4.1	169	336	5290	1.10	YSF	47 YR17	63M1-4	20
4.7	143	294	5420	1.30	YSA	47 YR17	63M1-4	18
5.4	98	257	5670	1.90	YSAF	47 YR17	63M1-4	19
6.0	118	229	5550	1.55				



技术参数

Technical Data

P <sub>1</sub> = 0.12 kW									
N <sub>A</sub> rpm	M <sub>2</sub> Nm	i	Fr <sub>2</sub> MAX[N]	f <sub>s</sub>	Type	Gear unit	Motor size		Kg
6.9	102	200	5610	1.80	YS	47 YR17	63M1-4		17
7.4	96	187	5640	1.95	YSF	47 YR17	63M1-4		20
					YSA	47 YR17	63M1-4		18
					YSAF	47 YR17	63M1-4		19
6.8	103	202	3000	0.90					
7.7	91	179	3000	1.00	YS	37 YR17	63M1-4		14
8.7	82	158	3000	1.15	YSF	37 YR17	63M1-4		15
9.6	75	144	3000	1.20	YSA	37 YR17	63M1-4		13
12	61	118	3000	1.50	YSAF	37 YR17	63M1-4		15
13	57	110	3000	1.60					
4.5	143	201.00	8050	2.1	YS	57	63M2-6		17
4.9	133	184.80	8090	2.3	YSF	57	63M2-6		21
5.7	116	158.12	8150	2.5	YSA	57	63M2-6		17
6.6	103	137.05	8180	2.9	YSAF	57	63M2-6		20
4.5	138	201.00	5490	1.30					
4.9	129	184.80	5540	1.40	YS	47	63M2-6		14
5.7	112	158.12	5610	1.55	YSF	47	63M2-6		17
6.6	99	137.05	5660	1.75	YSA	47	63M2-6		15
7.0	93	128.10	5680	1.85	YSAF	47	63M2-6		16
6.9	95	201.00	5680	1.80					
7.5	89	184.80	5700	1.90	YS	47	63M1-4		14
8.7	77	158.12	5740	2.2	YSF	47	63M1-4		17
10	68	137.05	5780	2.5	YSA	47	63M1-4		15
11	64	128.10	5790	2.6	YSAF	47	63M1-4		16
12	57	110.73	5810	3.0					
5.7	5.7	157.43	3000	0.85					
6.2	6.2	144.40	3000	0.95	YS	37	63M2-6		11
7.3	7.3	122.94	3000	1.05	YSF	37	63M2-6		12
8.5	8.5	106.00	3000	1.20	YSA	37	63M2-6		10
9.1	9.1	98.80	3000	1.30	YSAF	37	63M2-6		12
10	10	86.36	3000	1.45					
8.8	74	157.43	3000	1.25					
9.6	68	144.40	3000	1.35	YS	37	63M1-4		11
11	60	122.94	3000	1.55	YSF	37	63M1-4		12
13	52	106.00	3000	1.70	YSA	37	63M1-4		10
14	49	98.80	3000	1.75	YSAF	37	63M1-4		12
16	44	86.36	3000	1.95					
17	41	80.96	3000	2.1					



技术参数

Technical Data

<b>P<sub>1</sub> = 0.12 kW</b>								
--------------------------------	--	--	--	--	--	--	--	--

N <sub>A</sub> rpm	M <sub>2</sub> Nm	i	Fr <sub>2</sub> MAX[N]	f <sub>s</sub>	Type	Gear unit	Motor size	Kg
19	37	71.44	3000	2.3				
22	33	63.33	3000	2.5				
25	35	55.93	3000	2.3				
27	33	51.30	3000	2.5				
32	28	43.68	3000	2.9				
37	25	37.66	3000	3.2	YS	37	63M1-4	14
39	23	35.10	3000	3.4	YSF	37	63M1-4	15
45	20	30.68	3000	3.7	YSA	37	63M1-4	13
48	19	28.76	3000	3.9	YSAF	37	63M1-4	15
54	17	25.38	3000	4.4				
61	15	22.50	3000	4.8				
69	14	19.89	3000	3.6				
76	13	18.24	3000	3.9				
89	11	15.53	2870	4.4				

<b>P<sub>1</sub> = 0.18 kW</b>								
--------------------------------	--	--	--	--	--	--	--	--

					YS	87 YR57	63M2-4	110
0.29	3010	4606	19200	0.85	YSF	87 YR57	63M2-4	130
0.34	2520	3872	27500	1.00	YSA	87 YR57	63M2-4	105
					YSAF	87 YR57	63M2-4	120
<hr/>								
0.38	2430	3475	27700	1.05				
0.45	2030	2905	28400	1.25				
0.51	1760	2586	28800	1.40	YS	87 YR57	63M2-4	105
0.57	1570	2335	29100	1.60	YSF	87 YR57	63M2-4	130
0.64	1360	2054	29300	1.85	YSA	87 YR57	63M2-4	105
0.72	1210	1824	29500	2.1	YSAF	87 YR57	63M2-4	120
0.81	1080	1631	29600	2.3				
<hr/>								
0.94	1250	1404	11900	1.00	YS	77 YR37	63M2-4	59
1.1	1100	1245	13200	1.15	YSF	77 YR37	63M2-4	68
					YSA	77 YR37	63M2-4	58
					YSAF	77 YR37	63M2-4	65
<hr/>								
1.2	1020	1100	13700	1.20				
1.4	880	954	14500	1.40	YS	77 YR37	63M2-4	58
1.6	770	837	15000	1.60	YSF	77 YR37	63M2-4	68
1.9	640	714	15600	1.95	YSA	77 YR37	63M2-4	58
2.1	570	637	15800	2.2	YSAF	77 YR37	63M2-4	65
2.3	515	574	16000	2.4				
<hr/>								
1.9	600	712	7860	0.95				
2.1	505	615	8800	1.15	YS	67 YR37	63M2-4	39
2.4	450	543	9230	1.25	YSF	67 YR37	63M2-4	46
2.8	380	469	9720	1.50	YSA	67 YR37	63M2-4	40
3.1	340	424	9930	1.65	YSAF	67 YR37	63M2-4	45
3.6	305	365	10100	1.85				



技术参数

Technical Data

P <sub>1</sub> = 0.18 kW								
N <sub>A</sub> rpm	M <sub>2</sub> Nm	i	Fr <sub>2</sub> MAX[N]	f <sub>s</sub>	Type	Gear unit	Motor size	 Kg
3.0	355	438	6520	0.85				
3.4	315	388	6970	0.95				
3.9	275	336	7290	1.10	YS	57 YR17	63M2-4	20
4.5	240	294	7560	1.25	YSF	57 YR17	63M2-4	24
4.9	225	269	7650	1.35	YSA	57 YR17	63M2-4	20
5.8	193	229	7830	1.55	YSAF	57 YR17	63M2-4	23
6.5	174	204	7930	1.75				
7.0	159	187	7990	1.90				
4.5	235	294	4480	0.80				
5.1	162	257	5380	1.15				
5.8	190	229	5170	0.95	YS	47 YR17	63M2-4	17
6.6	167	200	5300	1.10	YSF	47 YR17	63M2-4	20
7.0	156	187	5360	1.20	YSA	47 YR17	63M2-4	18
8.0	138	165	5450	1.35	YSAF	47 YR17	63M2-4	19
9.0	124	148	5520	1.50				
10	110	131	5580	1.70				
4.0	255	217.41	10300	2.2	YS	67	71M1-6	29
4.6	225	190.11	10400	2.5	YSF	67	71M1-6	35
4.8	215	180.60	10400	2.6	YSA	67	71M1-6	30
					YSAF	67	71M1-6	34
4.3	220	201.00	7670	1.35	YS	57	71M1-6	18
4.7	205	184.80	7760	1.45	YSF	57	71M1-6	22
5.5	180	158.12	7900	1.65	YSA	57	71M1-6	18
6.4	159	137.05	7990	1.85	YSAF	57	71M1-6	21
6.6	154	201.00	8010	1.90	YS	57	63M2-4	17
7.1	143	184.80	8050	2.1	YSF	57	63M2-4	21
8.3	125	158.12	8120	2.4	YSA	57	63M2-4	17
9.6	110	137.05	8160	2.7	YSAF	57	63M2-4	20
4.3	215	201.00	5090	0.85				
4.7	199	184.80	5180	0.90	YS	47	71M1-6	14
5.5	173	158.12	5320	1.00	YSF	47	71M1-6	18
6.4	153	137.05	5420	1.10	YSA	47	71M1-6	15
6.8	144	128.10	5470	1.20	YSAF	47	71M1-6	17
6.6	149	201.00	5440	1.15				
7.1	138	184.80	5490	1.25				
8.3	121	158.12	5570	1.40				
9.6	107	137.05	5630	1.60	YS	47	63M2-4	14
10	100	128.10	5660	1.65	YSF	47	63M2-4	17
12	88	110.73	5700	1.90	YSA	47	63M2-4	15
14	77	94.08	5750	2.2	YSAF	47	63M2-4	16
16	69	84.00	5770	2.4				
18	60	71.75	5800	2.8				
19	69	69.39	5750	2.2				



技术参数

Technical Data

<b>P<sub>1</sub> = 0.18 kW</b>								
--------------------------------	--	--	--	--	--	--	--	--

N <sub>A</sub> rpm	M <sub>2</sub> Nm	i	Fr <sub>2</sub> MAX[N]	f <sub>s</sub>	Type	Gear unit	Motor size	Kg
8.4	115	157.43	3000	0.80				
9.1	107	144.40	3000	0.85				
11	93	122.94	3000	1.00				
12	82	106.00	3000	1.10				
13	77	98.80	3000	1.15				
15	68	86.36	3000	1.25				
16	64	80.96	3000	1.30				
18	58	71.44	3000	1.45				
21	52	63.33	3000	1.60				
24	55	55.93	3000	1.45				
26	51	51.30	3000	1.60				
30	44	43.68	3000	1.85	YS	37	63M2-4	11
35	38	37.66	3000	2.1	YSF	37	63M2-4	12
38	36	35.10	3000	2.2	YSA	37	63M2-4	10
43	32	30.68	3000	2.4	YSAF	37	63M2-4	12
46	30	28.76	3000	2.5				
52	27	25.38	3000	2.8				
59	24	22.50	3000	3.1				
66	22	19.89	3000	2.3				
72	21	18.24	2940	2.5				
85	18	15.53	2810	2.8				
99	15	13.39	2700	3.2				
106	14	12.48	2650	3.4				
121	13	10.91	2550	3.8				
129	12	10.23	2500	4.0				

<b>P<sub>1</sub> = 0.25 kW</b>								
--------------------------------	--	--	--	--	--	--	--	--

0.45	2930	2905	22200	0.85				
0.50	2560	2586	27400	1.00				
0.56	2300	2335	27900	1.10	YS	87 YR57	71M1-4	110
0.63	2000	2054	28400	1.25	YSF	87 YR57	71M1-4	130
0.71	1770	1824	28800	1.40	YSA	87 YR57	71M1-4	105
0.80	1590	1631	29100	1.60	YSAF	87 YR57	71M1-4	120
1.4	930	930	29700	2.7				
<hr/>								
1.4	1260	954	11800	1.00				
1.6	1110	837	13100	1.10	YS	77 YR37	71M1-4	59
1.8	930	714	14200	1.35	YSF	77 YR37	71M1-4	69
2.0	820	637	14800	1.50	YSA	77 YR37	71M1-4	59
2.3	745	574	15200	1.65	YSAF	77 YR37	71M1-4	65
2.6	640	499	15600	1.95				
<hr/>								
2.4	650	543	6280	0.85	YS	67 YR37	71M1-4	40
2.8	550	469	8390	1.05	YSF	67 YR37	71M1-4	46
3.1	495	424	8880	1.15	YSA	67 YR37	71M1-4	41
					YSAF	67 YR37	71M1-4	45



技术参数

Technical Data

P <sub>1</sub> = 0.25 kW								
N <sub>A</sub> rpm	M <sub>2</sub> Nm	i	Fr <sub>2</sub> MAX[N]	f <sub>s</sub>	Type	Gear unit	Motor size	 Kg
3.6	440	365	9320	1.30	YS	67 YR37	71M1-4	40
4.1	380	319	9700	1.50	YSF	67 YR37	71M1-4	46
4.6	335	281	9960	1.70	YSA	67 YR37	71M1-4	41
					YSAF	67 YR37	71M1-4	45
4.4	345	294	6640	0.85				
4.8	320	269	6870	0.95	YS	57 YR17	71M1-4	
5.7	275	229	7280	1.10	YSF	57 YR17	71M1-4	21
6.4	250	204	7490	1.20	YSA	57 YR17	71M1-4	25
6.9	230	187	7630	1.30	YSAF	57 YR17	71M1-4	21
7.9	200	165	7780	1.50				24
9.9	162	131	7980	1.85				
3.1	435	217.41	9350	1.30	YS	67	80M2-8	33
3.6	390	190.11	9670	1.45	YSF	67	80M2-8	40
3.8	370	180.60	9770	1.50	YSA	67	80M2-8	34
4.3	330	158.45	9980	1.70	YSAF	67	80M2-8	39
4.0	350	217.41	9890	1.60	YS	67	71M2-6	30
4.6	310	190.11	10100	1.80	YSF	67	71M2-6	37
4.9	295	180.60	10100	1.90	YSA	67	71M2-6	31
5.5	265	158.45	10300	2.1	YSAF	67	71M2-6	36
6.0	245	217.41	10300	2.1				
6.8	220	190.11	10400	2.4	YS	67	71M1-4	29
7.2	210	180.60	10500	2.5	YSF	67	71M1-4	35
8.2	187	158.45	10500	2.8	YSA	67	71M1-4	30
9.7	161	134.40	10600	3.2	YSAF	67	71M1-4	34
11	147	121.33	10600	3.5				
12	131	106.75	10700	4.0				
4.4	305	201.00	7050	1.00	YS	57	71M2-6	19
4.8	285	184.80	7230	1.05	YSF	57	71M2-6	23
5.6	245	158.12	7510	1.20	YSA	57	71M2-6	19
6.4	220	137.05	7690	1.35	YSAF	57	71M2-6	22
6.9	205	128.10	7760	1.45				
6.5	215	201.00	7700	1.35				
7.0	200	184.80	7790	1.45				
8.2	176	158.12	7920	1.70	YS	57	71M1-4	18
9.5	155	137.05	8010	1.90	YSF	57	71M1-4	22
10	146	128.10	8040	2.0	YSA	57	71M1-4	18
12	129	110.73	8110	2.3	YSAF	57	71M1-4	21
14	111	94.08	8160	2.7				
15	101	84.00	8190	2.9				
6.5	210	201.00	5120	0.80	YS	47	71M1-4	14
7.0	195	184.80	5210	0.85	YSF	47	71M1-4	18
					YSA	47	71M1-4	15
					YSAF	47	71M1-4	17



技术参数

Technical Data

P <sub>1</sub> = 0.25 kW								
NA rpm	M <sub>2</sub> Nm	i	Fr <sub>2</sub> MAX[N]	f <sub>s</sub>	Type	Gear unit	Motor size	 Kg
8.2	170	158.12	5340	1.00	YS	47	71M1-4	14
9.5	150	137.05	5440	1.10	YSF	47	71M1-4	18
10	141	128.10	5480	1.20	YSA	47	71M1-4	15
12	124	110.73	5560	1.35	YSAF	47	71M1-4	17
14	108	94.08	5630	1.55				
15	98	84.00	5670	1.70				
18	85	71.75	5720	1.95	YS	47	71M1-4	14
19	97	69.39	5640	1.60	YSF	47	71M1-4	18
19	80	67.20	5740	2.1	YSA	47	71M1-4	15
20	90	63.80	5670	1.70	YSAF	47	71M1-4	17
24	78	54.59	5720	2.0				
27	68	47.32	5760	2.3				
13	108	98.80	3000	0.80				
15	96	86.36	3000	0.90				
16	91	80.96	3000	0.95				
18	81	71.44	3000	1.05				
21	73	63.33	3000	1.10				
23	78	55.93	3000	1.05				
25	72	51.30	3000	1.15				
30	62	43.68	3000	1.30				
35	54	37.66	3000	1.45				
37	51	35.10	3000	1.55				
42	45	30.68	3000	1.70	YS	37	71M1-4	11
45	42	28.76	3000	1.80	YSF	37	71M1-4	13
51	37	25.38	3000	2.0	YSA	37	71M1-4	11
58	33	22.50	3000	2.2	YSAF	37	71M1-4	13
65	32	19.89	2870	1.65				
71	29	18.24	2820	1.80				
84	25	15.53	2710	2.0				
97	22	13.39	2620	2.3				
104	20	12.48	2570	2.4				
119	18	10.91	2480	2.7				
127	17	10.23	2440	2.8				
144	15	9.02	2360	3.1				
163	13	8.00	2290	3.4				
191	11	6.80	2180	3.8				
92	21	28.76	2740	3.0				
105	19	25.38	2650	3.3				
118	17	22.50	2560	3.4	YS	37	63M2-2	11
134	16	19.89	2410	2.8	YSF	37	63M2-2	12
146	15	18.24	2350	3.0	YSA	37	63M2-2	10
171	13	15.53	2250	3.4	YSAF	37	63M2-2	12
199	11	13.39	2160	3.8				
213	10	12.48	2120	4.0				



技术参数

Technical Data

P <sub>1</sub> = 0.37 kW								
N <sub>A</sub> rpm	M <sub>2</sub> Nm	i	Fr <sub>2</sub> MAX[N]	f <sub>s</sub>	Type	Gear unit	Motor size	 Kg
0.67	2860	2054	24500	0.90	YS	87 YR57	71M2-4	110
0.76	2540	1824	27400	1.00	YSF	87 YR57	71M2-4	130
0.85	2270	1631	28000	1.10	YSA	87 YR57	71M2-4	105
1.5	1340	930	29400	1.85	YSAF	87 YR57	71M2-4	125
1.7	1210	831	29500	2.1				
1.9	1310	714	11300	0.95				
2.2	1170	637	12600	1.05	YS	77 YR37	71M2-4	60
2.4	1060	574	13400	1.15	YSF	77 YR37	71M2-4	70
2.8	910	499	14300	1.35	YSA	77 YR37	71M2-4	59
3.1	800	438	14900	1.55	YSAF	77 YR37	71M2-4	66
3.6	710	389	15300	1.75				
3.8	625	365	7560	0.90	YS	67 YR37	71M2-4	41
4.3	545	319	8450	1.05	YSF	67 YR37	71M2-4	47
4.9	480	281	9030	1.20	YSA	67 YR37	71M2-4	42
5.6	430	246	9380	1.30	YSAF	67 YR37	71M2-4	46
2.4	980	288.00	29700	2.5	YS	87	90S-8	95
2.6	890	258.18	29800	2.8	YSF	87	90S-8	115
3.1	775	222.40	29900	3.2	YSA	87	90S-8	93
					YSAF	87	90S-8	110
3.0	735	225.26	15200	1.75	YS	77	90S-8	59
3.2	700	214.00	15300	1.80	YSF	77	90S-8	69
3.6	630	189.09	15600	2.0	YSA	77	90S-8	59
4.2	545	161.60	15900	2.3	YSAF	77	90S-8	66
3.5	645	256.47	15600	2.0	YS	77	80M1-6	52
4.0	575	225.26	15800	2.2	YSF	77	80M1-6	62
4.2	545	214.00	15900	2.3	YSA	77	80M1-6	52
					YSAF	77	80M1-6	59
4.1	505	217.41	8810	1.10	YS	67	80M1-6	32
4.7	450	190.11	9260	1.25	YSF	67	80M1-6	39
5.0	430	180.60	9400	1.30	YSA	67	80M1-6	33
5.7	380	158.45	9700	1.45	YSAF	67	80M1-6	38
6.4	345	217.41	9900	1.50				
7.3	310	190.11	10100	1.70	YS	67	71M2-4	30
7.6	295	180.60	10200	1.75	YSF	67	71M2-4	37
8.7	260	158.45	10300	2.0	YSA	67	71M2-4	31
10	225	134.40	10400	2.3	YSAF	67	71M2-4	36
11	205	121.33	10500	2.5				



技术参数

Technical Data

P <sub>1</sub> = 0.37 kW								
N <sub>A</sub> rpm	M <sub>2</sub> Nm	i	Fr <sub>2</sub> MAX[N]	f <sub>s</sub>	Type	Gear unit	Motor size	 Kg
5.7	360	158.12	6490	0.80				
6.6	315	137.05	6930	0.95	YS	57	80M1-6	80M1-6
7.0	300	128.10	7100	1.00	YSF	57	80M1-6	80M1-6
8.1	265	110.73	7390	1.10	YSA	57	80M1-6	80M1-6
9.6	230	94.08	7630	1.30	YSAF	57	80M1-6	80M1-6
11	205	84.00	7760	1.45				
6.9	305	201.00	7050	0.95				
7.5	285	184.80	7230	1.05				
8.7	245	158.12	7510	1.20				
10	220	137.05	7690	1.35				
11	205	128.10	7770	1.45	YS	57	71M2-4	19
12	180	110.73	7900	1.65	YSF	57	71M2-4	23
15	156	94.08	8000	1.90	YSA	57	71M2-4	19
16	141	84.00	8060	2.1	YSAF	57	71M2-4	22
19	122	71.75	8130	2.4				
20	139	69.39	8070	1.75				
21	115	67.20	8150	2.5				
22	128	63.80	8110	1.90				
10	210	137.05	5110	0.80				
11	199	128.10	5190	0.85				
12	175	110.73	5320	0.95				
15	151	94.08	5430	1.10				
16	137	84.00	5500	1.20				
19	119	71.75	5580	1.40				
20	136	69.39	5460	1.15				
21	112	67.20	5610	1.50				
22	126	63.80	5510	1.25	YS	47	71M2-4	15
25	109	54.59	5590	1.40	YSF	47	71M2-4	19
29	96	47.32	5410	1.60	YSA	47	71M2-4	16
31	90	44.22	5330	1.75	YSAF	47	71M2-4	18
36	78	38.23	5140	2.0				
42	67	32.48	4930	2.3				
48	60	29.00	4790	2.6				
56	52	24.77	4590	3.0				
59	49	23.20	4510	3.1				
68	46	20.33	4180	2.4				
78	40	17.62	4030	2.8				
84	37	16.47	3960	3.0				
22	103	63.33	3000	0.80				
27	101	51.30	3000	0.80	YS	37	71M2-4	12
32	87	43.68	3000	0.95	YSF	37	71M2-4	14
37	76	37.66	3000	1.05	YSA	37	71M2-4	12
39	71	35.10	3000	1.10	YSAF	37	71M2-4	13
45	63	30.68	3000	1.20				



技术参数

Technical Data

**P<sub>1</sub> = 0.37 kW**

N <sub>A</sub> rpm	M <sub>2</sub> Nm	I	Fr <sub>2</sub> MAX[N]	f <sub>s</sub>	Type	Gear unit	Motor size	 Kg
48	59	28.76	3000	1.30				
54	52	25.38	2940	1.40				
61	47	22.50	2870	1.55				
69	44	19.89	2610	1.20				
76	41	18.24	2570	1.30				
89	35	15.53	2500	1.45	YS	37	71M2-4	12
103	30	13.39	2420	1.60	YSF	37	71M2-4	14
111	28	12.48	2390	1.70	YSA	37	71M2-4	12
127	25	10.91	2320	1.95	YSAF	37	71M2-4	13
135	23	10.23	2280	2.0				
153	21	9.02	2220	2.2				
173	18	8.00	2150	2.5				
203	16	6.80	2070	2.7				
104	28	25.38	2540	2.2				
118	25	22.50	2460	2.3				
133	24	19.89	2290	1.85				
145	22	18.24	2250	2.0	YS	37	71M1-2	11
171	19	15.53	2160	2.3	YSF	37	71M1-2	13
198	16	13.39	2080	2.6	YSA	37	71M1-2	11
212	15	12.48	2040	2.7	YSAF	37	71M1-2	13
243	13	10.91	1970	3.0				
259	12	10.23	1940	3.1				
294	11	9.02	1870	3.3				

**P<sub>1</sub> = 0.55 kW**

1.0	2850	1332	24800	0.90				
1.1	2570	1191	27300	0.95				
1.3	2240	1032	28000	1.10				
1.5	2070	930	28300	1.20	YS	87 YR57	80M1-4	110
1.6	1870	831	28700	1.35	YSF	87 YR57	80M1-4	135
1.9	1620	719	29000	1.55	YSA	87 YR57	80M1-4	110
2.2	1420	624	29300	1.75	YSAF	87 YR57	80M1-4	125
2.4	1280	558	29400	1.95				
3.1	1020	435	29700	2.4				
3.1	1230	438	12100	1.00	YS	77 YR37	80M1-4	62
3.5	1090	389	13200	1.15	YSF	77 YR37	80M1-4	72
4.2	920	327	14300	1.35	YSA	77 YR37	80M1-4	61
4.7	830	289	14800	1.50	YSAF	77 YR37	80M1-4	68
5.4	720	250	15300	1.70				
5.5	660	246	5530	0.85	YS	67 YR37	80M1-4	43
6.2	590	221	7990	0.95	YSF	67 YR37	80M1-4	49
6.9	535	198	8520	1.05	YSA	67 YR37	80M1-4	44
8.1	460	168	9180	1.25	YSAF	67 YR37	80M1-4	48



技术参数

Technical Data

P <sub>1</sub> = 0.55 kW								
N <sub>A</sub> rpm	M <sub>2</sub> Nm	i	Fr <sub>2</sub> MAX[N]	f <sub>s</sub>	Type	Gear unit	Motor size	 Kg
2.4	1450	288.00	29200	1.70	YS	87	90L-8	96
2.6	1320	258.18	29400	1.85	YSF	87	90L-8	120
3.1	1150	222.40	29600	2.1	YSA	87	90L-8	94
					YSAF	87	90L-8	110
3.1	1130	288.00	29600	2.2	YS	87	80M2-6	90
3.5	1020	258.18	29700	2.4	YSF	87	80M2-6	110
4.0	900	222.40	29800	2.7	YSA	87	80M2-6	88
4.4	820	202.96	29800	2.9	YSAF	87	80M2-6	105
3.0	1090	225.26	13200	1.15	YS	77	90L-8	60
3.2	1040	214.00	13500	1.20	YSF	77	90L-8	70
3.6	930	189.09	14200	1.35	YSA	77	90L-8	60
4.2	810	161.60	14900	1.55	YSAF	77	90L-8	67
3.5	960	256.47	14100	1.35	YS	77	80M2-6	54
4.0	850	225.26	14700	1.50	YSF	77	80M2-6	64
4.2	810	214.00	14800	1.55	YSA	77	80M2-6	54
4.8	730	189.09	15200	1.75	YSAF	77	80M2-6	61
5.6	635	161.60	15600	2.0				
5.3	660	256.47	15500	1.90	YS	77	80M1-4	52
6.0	590	225.26	15800	2.2	YSF	77	80M1-4	62
6.4	560	214.00	15800	2.3	YSA	77	80M1-4	52
7.2	505	189.09	16000	2.5	YSAF	77	80M1-4	59
6.3	520	217.41	8660	1.00				
7.2	465	190.11	9150	1.10				
7.5	445	180.60	9300	1.15				
8.6	395	158.45	9620	1.30	YS	67	80M1-4	32
10	340	134.40	9930	1.55	YSF	67	80M1-4	39
11	310	121.33	10100	1.65	YSA	67	80M1-4	33
13	275	106.75	10200	1.85	YSAF	67	80M1-4	38
13	265	100.80	10300	1.95				
16	230	85.83	10400	2.3				
18	230	75.06	10400	2.1				
21	205	65.63	10500	2.4				
9.6	340	94.08	6710	0.85				
11	305	84.00	7030	0.95				
13	265	71.75	7360	1.10	YS	57	80M2-6	22
13	250	67.20	7470	1.15	YSF	57	80M2-6	26
16	245	54.59	7520	1.10	YSA	57	80M2-6	22
19	215	47.32	7710	1.25	YSAF	57	80M2-6	25
20	200	44.22	7790	1.35				
24	176	38.23	7920	1.55				



技术参数

Technical Data

P <sub>1</sub> = 0.55 kW								
N <sub>A</sub> rpm	M <sub>2</sub> Nm	i	Fr <sub>2</sub> MAX[N]	f <sub>s</sub>	Type	Gear unit	Motor size	 Kg
8.6	370	158.12	6330	0.80				
9.9	330	137.05	6820	0.90				
11	310	128.10	7010	0.95				
12	270	110.73	7320	1.10				
14	235	94.08	7590	1.25				
16	210	84.00	7730	1.40				
19	184	71.75	7880	1.55				
20	174	67.20	7930	1.65	YS	57	80M1-4	21
25	167	54.59	7960	1.45	YSF	57	80M1-4	25
29	146	47.32	8040	1.70	YSA	57	80M1-4	21
31	137	44.22	8080	1.80	YSAF	57	80M1-4	24
36	120	38.23	8130	2.1				
42	103	32.48	7970	2.4				
47	92	29.00	7730	2.7				
55	79	24.77	7390	3.1				
59	75	23.20	7250	3.3				
67	69	20.33	6760	2.4				
16	205	84.00	5140	0.80				
19	179	71.75	5290	0.95				
20	169	67.20	5350	1.00				
25	165	54.59	5130	0.95				
29	144	47.32	5010	1.10				
31	135	44.22	4950	1.15				
36	118	38.23	4810	1.30				
42	101	32.48	4650	1.55	YS	47	80M1-4	17
47	91	29.00	4540	1.70	YSF	47	80M1-4	21
55	78	24.77	4380	2.0	YSA	47	80M1-4	18
59	74	23.20	4310	2.1	YSAF	47	80M1-4	20
67	69	20.33	3920	1.60				
77	60	17.62	3810	1.85				
83	56	16.47	3750	1.95				
96	49	14.24	3630	2.3				
112	42	12.10	3500	2.6				
126	37	10.80	3400	2.9				
147	32	9.23	3270	3.4				
44	94	30.68	2680	0.80				
47	89	28.76	2670	0.85				
54	79	25.38	2630	0.95				
60	70	22.50	2600	1.05	YS	37	80M1-4	14
71	60	19.13	2540	1.20	YSF	37	80M1-4	16
88	53	15.53	2230	0.95	YSA	37	80M1-4	14
102	46	13.39	2200	1.10	YSAF	37	80M1-4	15
109	43	12.48	2180	1.15				
125	37	10.91	2130	1.30				
133	35	10.23	2110	1.35				



技术参数

Technical Data

<b>P<sub>1</sub> = 0.55 kW</b>								
--------------------------------	--	--	--	--	--	--	--	--

N <sub>A</sub> rpm	M <sub>2</sub> Nm	i	Fr <sub>2</sub> MAX[N]	f <sub>s</sub>	Type	Gear unit	Motor size	Kg
151	31	9.02	2070	1.50	YS	37	80M1-4	14
170	28	8.00	2020	1.60	YSF	37	80M1-4	16
200	24	6.80	1950	1.80	YSA	37	80M1-4	14
					YSAF	37	80M1-4	15
94	46	28.76	2420	1.40				
106	41	25.38	2360	1.50				
120	37	22.50	2310	1.55				
136	34	19.89	2100	1.30				
148	32	18.24	2070	1.40	YS	37	71M2-2	12
174	27	15.53	2010	1.55	YSF	37	71M2-2	14
202	24	13.39	1950	1.75	YSA	37	71M2-2	12
216	22	12.48	1920	1.85	YSAF	37	71M2-2	13
248	19	10.91	1870	2.0				
264	18	10.23	1840	2.1				
299	16	9.02	1780	2.3				
338	14	8.00	1730	2.5				
397	12	6.80	1660	2.4				

<b>P<sub>1</sub> = 0.75 kW</b>								
--------------------------------	--	--	--	--	--	--	--	--

1.1	4910	1223	18400	0.85				
1.3	4300	1070	29800	1.00				
1.5	3710	928	33800	1.15	YS	97 YR57	80M2-4	170
1.7	3270	824	34500	1.30	YSF	97 YR57	80M2-4	205
1.9	2330	714	35800	1.80	YSA	97 YR57	80M2-4	165
2.2	2480	626	35600	1.70	YSAF	97 YR57	80M2-4	195
2.6	2130	538	36000	1.95				
2.9	1930	484	36200	2.2				
1.3	3060	1032	17400	0.80				
1.5	2820	930	25300	0.90				
1.7	2540	831	27400	1.00	YS	87 YR57	80M2-4	110
1.9	2220	719	28100	1.15	YSF	87 YR57	80M2-4	135
2.2	1940	624	28500	1.30	YSA	87 YR57	80M2-4	110
2.5	1750	558	28800	1.45	YSAF	87 YR57	80M2-4	125
3.2	1400	435	29300	1.75				
4.3	1070	323	29600	2.2				
4.2	1250	327	11900	1.00	YS	77 YR37	80M2-4	63
4.8	1120	289	12900	1.10	YSF	77 YR37	80M2-4	73
5.5	970	250	14000	1.25	YSA	77 YR37	80M2-4	62
6.3	860	219	14600	1.45	YSAF	77 YR37	80M2-4	69



技术参数

Technical Data

P <sub>1</sub> = 0.75 kW								
N <sub>A</sub> rpm	M <sub>2</sub> Nm	i	Fr <sub>2</sub> MAX[N]	f <sub>s</sub>	Type	Gear unit	Motor size	 Kg
2.4	2040	286.40	36100	2.1	YS	97	100L1-8	160
2.6	1890	262.22	36300	2.2	YSF	97	100L1-8	195
3.0	1690	231.67	36400	2.5	YSA	97	100L1-8	155
					YSAF	97	100L1-8	185
3.1	1540	288.00	29100	1.60	YS	87	90S-6	95
3.5	1400	258.18	29300	1.75	YSF	87	90S-6	115
4.0	1220	222.40	29500	1.95	YSA	87	90S-6	93
4.4	1120	202.96	29600	2.1	YSAF	87	90S-6	110
4.8	1050	288.00	29600	2.2	YS	87	80M2-4	90
5.4	950	258.18	29700	2.4	YSF	87	80M2-4	110
6.2	830	222.40	29800	2.8	YSA	87	80M2-4	88
6.8	765	202.96	29900	3.0	YSAF	87	80M2-4	105
4.0	1160	225.26	12700	1.10	YS	77	90S-6	59
4.2	1110	214.00	13100	1.15	YSF	77	90S-6	69
4.8	990	189.09	13900	1.30	YSA	77	90S-6	59
5.6	860	161.60	14600	1.45	YSAF	77	90S-6	66
5.4	890	256.47	14500	1.45				
6.1	790	225.26	14900	1.60				
6.5	755	214.00	15100	1.70	YS	77	80M2-4	54
7.3	675	189.09	15400	1.90	YSF	77	80M2-4	64
8.5	585	161.60	15800	2.2	YSA	77	80M2-4	54
9.3	545	148.15	15900	2.3	YSAF	77	80M2-4	61
11	480	130.00	16000	2.5				
11	460	123.20	16000	2.6				
13	405	107.83	16000	2.9				
7.3	625	190.11	7570	0.85				
7.6	595	180.60	7900	0.85				
8.7	530	158.45	8570	1.00				
10	460	134.40	9180	1.15				
11	420	121.33	9470	1.25	YS	67	80M2-4	33
13	375	106.75	9750	1.40	YSF	67	80M2-4	40
14	355	100.80	9860	1.45	YSA	67	80M2-4	34
16	305	85.83	10100	1.70	YSAF	67	80M2-4	39
18	310	75.06	10100	1.55				
21	275	65.63	10200	1.75				
22	260	62.35	10300	1.85				
25	230	54.70	10300	2.1				
30	198	46.40	9840	2.4				
13	365	71.75	6430	0.80	YS	57	90S-6	27
13	345	67.20	6660	0.85	YSF	57	90S-6	31
16	295	56.61	7140	1.00	YSA	57	90S-6	27
19	295	47.32	7150	0.90	YSAF	57	90S-6	30
20	275	44.22	7300	1.00				



技术参数

Technical Data

P <sub>1</sub> = 0.75 kW								
N <sub>A</sub> rpm	M <sub>2</sub> Nm	i	Fr <sub>2</sub> MAX[N]	f <sub>s</sub>	Type	Gear unit	Motor size	 Kg
12	365	110.73	6400	0.80				
15	315	94.08	6930	0.95				
16	285	84.00	7210	1.05				
19	250	71.75	7500	1.15				
21	235	67.20	7590	1.20				
25	225	54.59	7650	1.10				
29	197	47.32	7810	1.25	YS	57	80M2-4	22
31	185	44.22	7870	1.35	YSF	57	80M2-4	26
36	161	38.23	7980	1.50	YSA	57	80M2-4	22
42	138	32.48	7670	1.80	YSAF	57	80M2-4	25
48	124	29.00	7450	2.0				
56	107	24.77	7150	2.3				
59	100	23.20	7030	2.5				
68	93	20.33	6490	1.80				
78	81	17.62	6260	2.1				
84	76	16.47	6160	2.2				
97	66	14.24	5930	2.6				
<hr/>								
29	194	47.32	4530	0.80	YS	47	80M2-4	18
31	182	44.22	4500	0.85	YSF	47	80M2-4	22
36	159	38.23	4420	1.00	YSA	47	80M2-4	19
42	136	32.48	4310	1.15	YSAF	47	80M2-4	21
48	122	29.00	4230	1.25				
<hr/>								
56	106	24.77	4110	1.45				
59	99	23.20	4060	1.55				
68	93	20.33	3610	1.20				
78	81	17.62	3530	1.35				
84	76	16.47	3490	1.45	YS	47	80M2-4	18
97	66	14.24	3410	1.65	YSF	47	80M2-4	22
114	56	12.10	3300	1.95	YSA	47	80M2-4	19
128	50	10.80	3230	2.2	YSAF	47	80M2-4	21
150	43	9.23	3120	2.5				
160	41	8.64	3070	2.7				
190	34	7.28	2950	3.0				
<hr/>								
72	81	19.13	2270	0.85				
111	57	12.48	1930	0.85	YS	37	80M2-4	15
127	50	10.91	1920	0.95	YSF	37	80M2-4	17
135	47	10.23	1910	1.00	YSA	37	80M2-4	15
153	42	9.02	1890	1.10	YSAF	37	80M2-4	16
173	37	8.00	1860	1.20				
203	32	6.80	1820	1.35				



技术参数

Technical Data

<b>P<sub>1</sub> = 0.75 kW</b>								
--------------------------------	--	--	--	--	--	--	--	--

N <sub>A</sub> rpm	M <sub>2</sub> Nm	i	Fr <sub>2</sub> MAX[N]	f <sub>s</sub>	Type	Gear unit	Motor size	Kg
141	43	19.13	2090	1.05				
174	37	15.53	1860	1.15				
202	32	13.39	1820	1.30				
216	30	12.48	1800	1.35	YS	37	80M1-2	14
248	26	10.91	1760	1.50	YSF	37	80M1-2	16
264	25	10.23	1740	1.55	YSA	37	80M1-2	14
299	22	9.02	1690	1.65	YSAF	37	80M1-2	15
338	19	8.00	1650	1.80				
397	17	6.80	1590	1.75				

<b>P<sub>1</sub> = 1.1 kW</b>								
-------------------------------	--	--	--	--	--	--	--	--

1.7	4780	824	22300	0.90				
2.0	3410	714	34300	1.25	YS	97 YR57	90S-4	175
2.2	3630	626	33900	1.15	YSF	97 YR57	90S-4	210
2.6	3120	538	34800	1.35	YSA	97 YR57	90S-4	170
2.9	2820	484	35200	1.50	YSAF	97 YR57	90S-4	200
3.3	2450	420	35700	1.70				
2.2	2840	624	24800	0.90				
2.5	2570	558	27300	0.95				
2.9	2260	485	28000	1.10				
3.2	2060	435	28300	1.20	YS	87 YR57	90S-4	115
3.7	1810	378	28700	1.35	YSF	87 YR57	90S-4	140
4.3	1570	323	29100	1.55	YSA	87 YR57	90S-4	115
5.0	1380	281	29300	1.75	YSAF	87 YR57	90S-4	130
5.5	1480	255	29200	1.35				
6.3	1300	222	29400	1.55				
6.8	1210	205	29500	1.65				
6.4	1250	219	11800	1.00	YS	77 YR37	90S-4	68
					YSF	77 YR37	90S-4	78
					YSA	77 YR37	90S-4	68
					YSAF	77 YR37	90S-4	74
2.3	3080	286.40	34800	1.35	YS	97	100L2-8	165
2.6	2840	262.22	35200	1.50	YSF	97	100L2-8	200
2.9	2540	231.67	35600	1.65	YSA	97	100L2-8	160
3.4	2190	196.52	36000	1.90	YSAF	97	100L2-8	185
3.2	2310	286.40	35900	1.80	YS	97	90L-6	155
3.5	2130	262.22	36000	1.95	YSF	97	90L-6	185
4.0	1900	231.67	36300	2.2	YSA	97	90L-6	150
					YSAF	97	90L-6	175



技术参数

Technical Data

P <sub>1</sub> = 1.1 kW								
N <sub>A</sub> rpm	M <sub>2</sub> Nm	i	Fr <sub>2</sub> MAX[N]	f <sub>s</sub>	Type	Gear unit	Motor size	 Kg
3.2	2220	288.00	28100	1.10	YS	87	90L-6	96
3.6	2010	258.18	28400	1.20	YSF	87	90L-6	120
4.1	1760	222.40	28800	1.35	YSA	87	90L-6	94
4.5	1620	202.96	29000	1.45	YSAF	87	90L-6	110
4.9	1520	288.00	29100	1.50				
5.4	1370	258.18	29300	1.65	YS	87	90S-4	95
6.3	1200	222.40	29500	1.90	YSF	87	90S-4	115
6.9	1100	202.96	29600	2.1	YSA	87	90S-4	93
7.8	990	180.00	29700	2.2	YSAF	87	90S-4	110
9.2	840	151.30	29800	2.6				
6.2	1150	225.26	12800	1.10				
6.5	1100	214.00	13200	1.15				
7.4	980	189.09	13900	1.30				
8.7	850	161.60	14700	1.50	YS	77	90S-4	59
9.5	785	148.15	15000	1.60	YSF	77	90S-4	69
11	695	130.00	15400	1.75	YSA	77	90S-4	59
11	665	123.20	15500	1.80	YSAF	77	90S-4	66
13	585	107.83	15800	2.0				
14	535	97.14	15900	2.1				
16	470	85.22	16000	2.3				
12	605	121.33	7790	0.85				
13	540	106.75	8490	0.95				
14	515	100.80	8740	1.00				
16	445	85.83	9300	1.15				
18	405	78.00	9550	1.30				
21	400	65.63	9610	1.20	YS	67	90S-4	39
22	380	62.35	9720	1.25	YSF	67	90S-4	45
26	335	54.70	9560	1.45	YSA	67	90S-4	40
30	285	46.40	9240	1.65	YSAF	67	90S-4	44
33	260	41.89	9040	1.85				
38	230	36.85	8780	2.1				
40	220	34.80	8660	2.2				
47	187	29.63	8330	2.6				
20	360	71.75	6480	0.80	YS	57	90S-4	27
21	340	67.20	6710	0.85	YSF	57	90S-4	31
25	290	56.61	7180	0.90	YSA	57	90S-4	27
30	285	47.32	7220	0.85	YSAF	57	90S-4	30



技术参数

Technical Data

P <sub>1</sub> = 1.1 kW								
N <sub>A</sub> rpm	M <sub>2</sub> Nm	i	Fr <sub>2</sub> MAX[N]	f <sub>s</sub>	Type	Gear unit	Motor size	 Kg
32	265	44.22	7360	0.90				
37	235	38.23	7410	1.05				
43	200	32.48	7170	1.25				
48	179	29.00	7000	1.35				
57	154	24.77	6760	1.60				
60	145	23.20	6660	1.70	YS	57	90S-4	27
72	123	19.54	6390	1.75	YSF	57	90S-4	31
79	117	17.62	5870	1.45	YSA	57	90S-4	27
85	110	16.47	5780	1.55	YSAF	57	90S-4	30
98	95	14.24	5610	1.75				
116	82	12.10	5400	2.1				
130	73	10.80	5260	2.3				
152	63	9.23	5050	2.7				
<hr/>								
48	177	29.00	3720	0.90				
57	153	24.77	3670	1.00	YS	47	90S-4	24
60	143	23.20	3640	1.05	YSF	47	90S-4	27
72	122	19.54	3560	1.20	YSA	47	90S-4	25
79	117	17.62	3070	0.95	YSAF	47	90S-4	26
85	109	16.47	3060	1.00				
<hr/>								
98	95	14.24	3030	1.15				
116	81	12.10	2980	1.35	YS	47	90S-4	24
130	73	10.80	2940	1.50	YSF	47	90S-4	27
152	63	9.23	2870	1.75	YSA	47	90S-4	25
162	59	8.64	2840	1.85	YSAF	47	90S-4	26
192	50	7.28	2750	2.1				
<hr/>								
175	54	8.00	1570	0.85	YS	37	90S-4	20
206	46	6.80	1580	0.95	YSF	37	90S-4	22
					YSA	37	90S-4	20
					YSAF	37	90S-4	22
<hr/>								
202	47	13.39	1590	0.85				
216	44	12.48	1580	0.90				
248	39	10.91	1570	1.00	YS	37	80M2-2	15
264	36	10.23	1560	1.05	YSF	37	80M2-2	17
299	32	9.02	1540	1.10	YSA	37	80M2-2	15
338	28	8.00	1510	1.25	YSAF	37	80M2-2	16
397	24	6.80	1470	1.20				



技术参数

Technical Data

P <sub>1</sub> = 1.5 kW								
N <sub>A</sub> rpm	M <sub>2</sub> Nm	i	Fr <sub>2</sub> MAX[N]	f <sub>s</sub>	Type	Gear unit	Motor size	 Kg
2.0	4640	714	28400	0.90				
2.2	4950	626	16200	0.85				
2.6	4260	538	30500	1.00	YS	97 YR57	90L-4	180
2.9	3850	484	33500	1.10	YSF	97 YR57	90L-4	210
3.4	3350	420	34400	1.25	YSA	97 YR57	90L-4	175
3.8	3030	376	34900	1.40	YSAF	97 YR57	90L-4	200
4.3	2660	327	35400	1.60				
2.9	3090	485	15900	0.80				
3.2	2810	435	25500	0.85				
3.7	2470	378	27600	1.00	YS	87 YR57	90L-4	120
4.4	2150	323	28200	1.10	YSF	87 YR57	90L-4	140
5.0	1890	281	28600	1.25	YSA	87 YR57	90L-4	115
5.5	2020	255	28400	1.00	YSAF	87 YR57	90L-4	135
6.4	1770	222	28800	1.10				
6.9	1650	205	28900	1.20				
2.4	4030	286.40	33100	1.05	YS	97	112M-8	175
2.7	3720	262.22	33700	1.15	YSF	97	112M-8	205
3.0	3330	231.67	34400	1.25	YSA	97	112M-8	170
3.6	2870	196.52	35200	1.45	YSAF	97	112M-8	195
3.2	3150	286.40	34700	1.35	YS	97	100L-6	160
3.5	2910	262.22	35100	1.45	YSF	97	100L-6	195
4.0	2600	231.67	35500	1.60	YSA	97	100L-6	155
4.7	2230	196.52	35900	1.90	YSAF	97	100L-6	185
4.9	2130	286.40	36000	1.90	YS	97	90L-4	155
5.4	1970	262.22	36200	2.0	YSF	97	90L-4	185
6.1	1760	231.67	36400	2.3	YSA	97	90L-4	150
7.2	1510	196.52	36600	2.7	YSAF	97	90L-4	175
3.6	2740	258.18	26600	0.90	YS	87	100L-6	105
4.1	2390	222.40	27700	1.00	YSF	87	100L-6	125
4.5	2200	202.96	28100	1.10	YSA	87	100L-6	100
5.1	1980	180.00	28500	1.20	YSAF	87	100L-6	120
4.9	2060	288.00	28300	1.10				
5.5	1860	258.18	28700	1.20				
6.3	1630	222.40	29000	1.40				
7.0	1500	202.96	29200	1.50	YS	87	90L-4	96
7.8	1340	180.00	29400	1.65	YSF	87	90L-4	120
9.3	1140	151.30	29600	1.90	YSA	87	90L-4	94
10	1060	139.05	29600	2.0	YSAF	87	90L-4	110
11	950	123.48	29700	2.2				
13	850	110.40	29800	2.4				
14	770	99.26	29900	2.5				



技术参数

Technical Data

P <sub>1</sub> = 1.5 kW								
NA rpm	M <sub>2</sub> Nm	i	Fr <sub>2</sub> MAX[N]	f <sub>s</sub>	Type	Gear unit	Motor size	 Kg
7.5	1330	189.09	10600	0.95				
8.7	1150	161.60	12700	1.10				
9.5	1060	148.15	13400	1.15				
11	940	130.00	14100	1.30				
11	900	123.20	14400	1.35				
13	795	107.83	14900	1.45				
15	725	97.14	15300	1.60	YS	77	90L-4	60
17	640	85.22	15400	1.70	YSF	77	90L-4	70
19	650	75.09	14100	1.70	YSA	77	90L-4	60
20	620	71.33	14000	1.80	YSAF	77	90L-4	67
21	510	66.67	14600	2.0				
22	550	63.03	13700	2.0				
25	440	56.92	14000	2.3				
26	470	53.87	13200	2.3				
29	435	49.38	13000	2.5				
33	385	43.33	12600	2.9				
16	600	85.83	7850	0.85	YS	67	90L-4	41
18	550	78.00	8390	0.95	YSF	67	90L-4	47
21	540	65.63	8510	0.90	YSA	67	90L-4	42
					YSAF	67	90L-4	46
23	515	62.35	8740	0.95				
26	455	54.70	8810	1.05				
30	390	46.40	8590	1.25				
34	355	41.89	8450	1.35				
38	310	36.85	8250	1.55				
41	295	34.80	8160	1.60	YS	67	90L-4	41
48	255	29.63	7900	1.90	YSF	67	90L-4	47
52	230	26.93	7740	2.1	YSA	67	90L-4	42
58	220	24.44	7000	1.55	YSAF	67	90L-4	46
61	210	23.22	6950	1.60				
69	186	20.37	6790	1.85				
82	159	17.28	6580	2.1				
90	144	15.60	6440	2.4				
103	127	13.73	6260	2.7				
43	270	32.48	6630	0.90				
49	245	29.00	6520	1.00				
57	210	24.77	6340	1.15				
61	196	23.20	6270	1.25	YS	57	90L-4	29
72	167	19.54	6060	1.30	YSF	57	90L-4	32
80	159	17.62	5430	1.05	YSA	57	90L-4	28
86	149	16.47	5380	1.15	YSAF	57	90L-4	31
99	129	14.24	5250	1.30				
117	110	12.10	5100	1.55				
131	99	10.80	4980	1.70				
153	85	9.23	4820	2.0				



技术参数

Technical Data

P <sub>1</sub> = 1.5 kW								
N <sub>A</sub> rpm	M <sub>2</sub> Nm	i	Fr <sub>2</sub> MAX[N]	f <sub>s</sub>	Type	Gear unit	Motor size	 Kg
99	129	14.24	2610	0.85	YS	47	90L-4	25
117	110	12.10	2620	1.00	YSF	47	90L-4	28
131	99	10.80	2620	1.10	YSA	47	90L-4	26
					YSAF	47	90L-4	28
153	85	9.23	2590	1.30	YS	47	90L-4	25
163	79	8.64	2580	1.35	YSF	47	90L-4	28
194	67	7.28	2530	1.55	YSA	47	90L-4	26
					YSAF	47	90L-4	28
310	42	9.02	1350	0.85	YS	37	90S-2	20
350	37	8.00	1350	0.95	YSF	37	90S-2	22
412	32	6.80	1330	0.90	YSA	37	90S-2	20
					YSAF	37	90S-2	22
P <sub>1</sub> = 2.2 kW								
3.4	4950	420	16300	0.85	YS	97 YR57	100L1-4	185
3.8	4460	376	27600	0.95	YSF	97 YR57	100L1-4	220
4.3	3910	327	33400	1.05	YSA	97 YR57	100L1-4	180
4.9	3460	287	34200	1.20	YSAF	97 YR57	100L1-4	205
5.6	3030	252	34900	1.40				
3.3	4530	286.40	30200	0.95	YS	97	112M-6	175
3.6	4180	262.22	32800	1.00	YSF	97	112M-6	205
4.1	3730	231.67	33700	1.15	YSA	97	112M-6	170
4.8	3210	196.52	34600	1.30	YSAF	97	112M-6	195
4.9	3130	286.40	34800	1.30				
5.4	2890	262.22	35100	1.40				
6.1	2570	231.67	35500	1.55				
7.2	2210	196.52	36000	1.80	YS	97	100L1-4	160
7.8	2050	180.95	36100	1.90	YSF	97	100L1-4	195
8.7	1840	161.74	36300	2.1	YSA	97	100L1-4	155
9.7	1670	145.60	36500	2.2	YSAF	97	100L1-4	185
11	1520	131.85	36600	2.4				
12	1360	116.92	36700	2.6				
13	1240	105.71	36800	2.8				
16	1060	89.60	36900	3.1				
5.5	2730	258.18	26800	0.85				
6.3	2380	222.40	27700	0.95	YS	87	100L1-4	105
7.0	2190	202.96	28100	1.05	YSF	87	100L1-4	125
7.8	1970	180.00	28500	1.10	YSA	87	100L1-4	100
9.3	1680	151.30	28900	1.30	YSAF	87	100L1-4	120
10	1550	139.05	29100	1.35				
11	1390	123.48	29300	1.50				



技术参数

Technical Data

P <sub>1</sub> = 2.2 kW								
N <sub>A</sub> rpm	M <sub>2</sub> Nm	i	Fr <sub>2</sub> MAX[N]	f <sub>s</sub>	Type	Gear unit	Motor size	 Kg
13	1250	110.40	29500	1.60				
14	1130	99.26	29600	1.75				
16	990	86.15	29700	1.90	YS	87	100L1-4	105
17	1060	81.76	29600	1.50	YSF	87	100L1-4	125
18	890	77.14	29800	2.0	YSA	87	100L1-4	100
20	920	70.43	29700	1.75	YSAF	87	100L1-4	120
22	840	64.27	29800	1.90				
25	750	57.00	29900	2.1				
<hr/>								
11	1390	130.00	6140	0.85				
11	1320	123.20	11100	0.90				
13	1170	107.83	12600	1.00				
15	1060	97.14	13400	1.10				
17	940	85.22	14100	1.15				
19	840	75.20	13800	1.30				
21	745	66.67	13500	1.40				
22	810	63.03	12400	1.35	YS	77	100L1-4	67
25	645	56.92	13100	1.55	YSF	77	100L1-4	77
26	695	53.87	12100	1.60	YSA	77	100L1-4	67
29	635	49.38	11900	1.75	YSAF	77	100L1-4	74
33	560	43.33	11700	1.95				
34	535	41.07	11600	2.1				
39	470	35.94	11300	2.3				
44	425	32.38	11000	2.6				
50	375	28.41	10700	2.8				
56	330	25.07	10400	3.1				
62	310	22.89	9490	2.3				
67	285	20.99	9340	2.5				
<hr/>								
30	570	46.40	7480	0.85				
34	515	41.89	7440	0.95				
38	460	36.85	7360	1.05				
41	435	34.80	7320	1.10				
48	370	29.63	7180	1.30				
52	340	26.93	7080	1.40				
60	295	23.33	6920	1.60	YS	67	100L1-4	48
69	275	20.37	6060	1.25	YSF	67	100L1-4	54
82	235	17.28	5960	1.45	YSA	67	100L1-4	49
90	210	15.60	5880	1.60	YSAF	67	100L1-4	53
103	186	13.73	5770	1.85				
109	176	12.96	5710	1.95				
128	151	11.03	5550	2.3				
141	137	10.03	5450	2.5				
162	119	8.69	5300	2.8				



技术参数

Technical Data

<b>P<sub>1</sub> = 2.2 kW</b>								
-------------------------------	--	--	--	--	--	--	--	--

N <sub>A</sub> rpm	M <sub>2</sub> Nm	i	Fr <sub>2</sub> MAX[N]	f <sub>s</sub>	Type	Gear unit	Motor size	Kg
99	190	14.24	4640	0.90				
117	162	12.10	4580	1.05	YS	57	100L1-4	35
131	145	10.80	4520	1.15	YSF	57	100L1-4	39
153	124	9.23	4420	1.35	YSA	57	100L1-4	35
163	117	8.64	4380	1.40	YSAF	57	100L1-4	38
194	99	7.28	4250	1.50				

<b>P<sub>1</sub> = 3.0 kW</b>								
-------------------------------	--	--	--	--	--	--	--	--

4.9	4760	287	22900	0.90	YS	97 YR57	100L2-4	190
5.6	4180	252	31900	1.00	YSF	97 YR57	100L2-4	225
6.4	3650	219	33900	1.15	YSA	97 YR57	100L2-4	185
6.8	3440	205	34300	1.20	YSAF	97 YR57	100L2-4	210
4.9	4290	286.40	32600	0.95				
5.3	3960	262.22	33300	1.00				
6.0	3530	231.67	34100	1.15				
7.1	3040	196.52	34900	1.30				
7.7	2810	180.95	35200	1.40	YS	97	100L2-4	165
8.7	2530	161.74	35600	1.50	YSF	97	100L2-4	200
9.6	2300	145.60	35900	1.65	YSA	97	100L2-4	160
11	2090	131.85	36100	1.75	YSAF	97	100L2-4	185
12	1870	116.92	36300	1.90				
13	1700	105.71	36400	2.0				
16	1450	89.60	36600	2.2				
17	1470	80.85	36600	2.2				
7.8	2700	180.00	27100	0.80				
9.2	2300	151.30	27900	0.95				
10	2130	139.05	28200	1.00				
11	1900	123.48	28600	1.10				
13	1720	110.40	28900	1.15				
14	1550	99.26	29100	1.25				
16	1360	86.15	29300	1.40	YS	87	100L2-4	110
17	1460	81.76	29200	1.10	YSF	87	100L2-4	130
18	1230	77.14	29500	1.50	YSA	87	100L2-4	105
20	1260	70.43	29400	1.25	YSAF	87	100L2-4	120
22	1160	64.27	29500	1.40				
25	1030	57.00	29700	1.55				
29	870	47.91	29800	1.85				
32	800	44.03	29800	2.0				
36	715	39.10	29900	2.2				
40	640	34.96	29900	2.5				
16	1290	85.22	11500	0.85	YS	77	100L2-4	71
19	1150	75.20	12500	0.95	YSF	77	100L2-4	81
21	1020	66.67	12400	1.00	YSA	77	100L2-4	71
22	1110	63.03	10900	1.00	YSAF	77	100L2-4	78



技术参数

Technical Data

<b>P<sub>1</sub> = 3.0 kW</b>								
-------------------------------	--	--	--	--	--	--	--	--

N <sub>A</sub> rpm	M <sub>2</sub> Nm	i	Fr <sub>2</sub> MAX[N]	f <sub>s</sub>	Type	Gear unit	Motor size	Kg
25	880	56.92	12100	1.10				
26	950	53.87	10800	1.15				
28	880	49.38	10800	1.25				
32	770	43.33	10700	1.40				
34	735	41.07	10600	1.50				
39	645	35.94	10400	1.70				
43	585	32.38	10300	1.85				
49	515	28.41	10100	2.0	YS	77	100L2-4	71
56	455	25.07	9840	2.2	YSF	77	100L2-4	81
61	430	22.89	8680	1.65	YSA	77	100L2-4	71
67	395	20.99	8590	1.80	YSAF	77	100L2-4	78
76	345	18.42	8450	2.0				
80	330	17.45	8390	2.2				
92	290	15.28	8210	2.5				
102	260	13.76	8060	2.7				
116	230	12.07	7870	3.1				
131	205	10.65	7670	3.6				
					YS	67	100L2-4	52
40	595	34.80	6350	0.80	YSF	67	100L2-4	58
47	510	29.63	6350	0.95	YSA	67	100L2-4	53
52	465	26.93	6330	1.05	YSAF	67	100L2-4	57
60	405	23.33	6270	1.20				
69	375	20.37	5230	0.90				
81	320	17.28	5250	1.05				
90	290	15.60	5240	1.15	YS	67	100L2-4	52
102	255	13.73	5210	1.35	YSF	67	100L2-4	58
108	240	12.96	5190	1.40	YSA	67	100L2-4	53
127	205	11.03	5100	1.65	YSAF	67	100L2-4	57
140	188	10.03	5050	1.80				
161	164	8.69	4940	2.1				
185	143	7.56	4830	2.1				
130	199	10.80	3990	0.85	YS	57	100L2-4	39
152	171	9.23	3970	1.00	YSF	57	100L2-4	43
162	160	8.64	3960	1.05	YSA	57	100L2-4	39
192	136	7.28	3900	1.10	YSAF	57	100L2-4	42

<b>P<sub>1</sub> = 4.0 kW</b>								
-------------------------------	--	--	--	--	--	--	--	--

					YS	97 YR57	112M-4	195
6.5	4820	219	21900	0.85	YSF	97 YR57	112M-4	230
6.9	4530	205	26700	0.95	YSA	97 YR57	112M-4	190
					YSAF	97 YR57	112M-4	220



**技术参数**

**Technical Data**

P <sub>1</sub> = 4.0 kW								
NA rpm	M <sub>2</sub> Nm	i	Fr <sub>2</sub> MAX[N]	f <sub>s</sub>	Type	Gear unit	Motor size	 Kg
6.1	4650	231.67	28300	0.85				
7.2	3990	196.52	33200	1.00				
7.9	3700	180.95	33800	1.05				
8.8	3330	161.74	34400	1.15				
9.8	3020	145.60	34900	1.25				
11	2750	131.85	35300	1.35	YS	97	112M-4	175
12	2460	116.92	35700	1.45	YSF	97	112M-4	205
13	2230	105.71	35900	1.55	YSA	97	112M-4	170
16	1910	89.60	36300	1.70	YSAF	97	112M-4	195
18	1940	80.85	36200	1.65				
20	1720	71.43	36400	1.90				
23	1470	60.59	36600	2.3				
25	1350	55.79	36700	2.4				
<hr/>								
12	2510	123.48	27500	0.80				
13	2260	110.40	28000	0.90				
14	2040	99.26	28400	0.95				
16	1790	86.15	28800	1.05				
18	1610	77.14	29000	1.15				
20	1660	70.43	28900	0.95	YS	87	112M-4	115
22	1520	64.27	29100	1.05	YSF	87	112M-4	135
25	1350	57.00	29300	1.20	YSA	87	112M-4	110
30	1150	47.91	29500	1.40	YSAF	87	112M-4	125
32	1060	44.03	29600	1.50				
36	940	39.10	29700	1.70				
41	840	34.96	29800	1.90				
45	760	31.43	29100	2.1				
52	665	27.28	28200	2.4				
56	635	25.50	26600	1.95				
<hr/>								
25	1160	56.92	10800	0.85	YS	77	112M-4	77
26	1250	53.87	9250	0.90	YSF	77	112M-4	87
29	1150	49.38	9320	0.95	YSA	77	112M-4	77
33	1020	43.33	9370	1.10	YSAF	77	112M-4	84
<hr/>								
35	960	41.07	9370	1.15				
40	850	35.94	9340	1.30				
44	765	32.38	9290	1.40				
50	675	28.41	9190	1.55				
57	600	25.07	9070	1.70				
62	565	22.89	7650	1.25	YS	77	112M-4	77
68	520	20.99	7650	1.35	YSF	77	112M-4	87
77	455	18.42	7620	1.55	YSA	77	112M-4	77
81	435	17.45	7590	1.65	YSAF	77	112M-4	84
93	380	15.28	7510	1.85				
103	345	13.76	7430	2.1				
118	300	12.07	7310	2.4				
133	265	10.65	7170	2.7				



技术参数

Technical Data

<b>P<sub>1</sub> = 4.0 kW</b>								
-------------------------------	--	--	--	--	--	--	--	--

N <sub>A</sub> rpm	M <sub>2</sub> Nm	i	Fr <sub>2</sub> MAX[N]	f <sub>s</sub>	Type	Gear unit	Motor size	Kg
150	235	9.44	7030	3.1	YS	77	112M-4	77
176	205	8.06	6830	3.4	YSF	77	112M-4	87
					YSA	77	112M-4	77
					YSAF	77	112M-4	84
82	420	17.28	3810	0.80				
91	380	15.60	4180	0.90				
103	335	13.73	4500	1.00	YS	67	112M-4	59
110	320	12.96	4520	1.05	YSF	67	112M-4	65
129	270	11.03	4530	1.25	YSA	67	112M-4	60
142	245	10.03	4520	1.35	YSAF	67	112M-4	64
163	215	8.69	4490	1.55				
188	188	7.56	4430	1.55				

<b>P<sub>1</sub> = 5.5 kW</b>								
-------------------------------	--	--	--	--	--	--	--	--

8.8	4550	161.74	29900	0.85				
9.8	4130	145.60	32900	0.90				
11	3760	131.85	33700	0.95				
12	3360	116.92	34400	1.05				
14	3050	105.71	34900	1.15				
16	2610	89.60	35500	1.25	YS	97	132S-4	180
18	2290	78.26	35900	1.35	YSF	97	132S-4	210
20	2350	71.43	35800	1.40	YSA	97	132S-4	175
22	1930	65.45	36200	1.50	YSAF	97	132S-4	200
24	2000	60.59	36200	1.65				
26	1850	55.79	36300	1.80				
29	1660	49.87	36500	2.0				
32	1500	44.89	36600	2.2				
35	1360	40.65	36700	2.4				
19	2200	77.14	28100	0.85				
22	1850	64.00	28700	0.90				
25	1850	57.00	28700	0.85				
30	1560	47.91	29100	1.00				
32	1440	44.03	29200	1.10				
37	1280	39.10	29200	1.25				
41	1150	34.96	28600	1.40				
45	1040	31.43	28000	1.55	YS	87	132S-4	120
52	910	27.28	27200	1.75	YSF	87	132S-4	140
56	870	25.50	25200	1.45	YSA	87	132S-4	115
67	730	21.43	24500	1.70	YSAF	87	132S-4	135
73	675	19.70	24100	1.85				
82	600	17.49	23500	2.1				
91	535	15.64	23000	2.3				
102	485	14.06	22500	2.6				
117	420	12.21	21800	3.0				
131	375	10.93	21200	3.3				



技术参数

Technical Data

<b>P<sub>1</sub> = 5.5 kW</b>								
-------------------------------	--	--	--	--	--	--	--	--

N <sub>A</sub> rpm	M <sub>2</sub> Nm	i	Fr <sub>2</sub> MAX[N]	f <sub>s</sub>	Type	Gear unit	Motor size	Kg
35	1320	41.07	7560	0.85	YS	77	132S-4	84
40	1160	35.94	7750	0.95	YSF	77	132S-4	94
44	1050	32.38	7850	1.05	YSA	77	132S-4	84
					YSAF	77	132S-4	91
50	920	28.41	7920	1.15				
57	820	25.07	7940	1.25				
64	725	22.22	7920	1.35				
78	625	18.42	5920	1.15	YS	77	132S-4	84
82	590	17.45	6170	1.20	YSF	77	132S-4	94
94	520	15.28	6490	1.35	YSA	77	132S-4	84
104	470	13.76	6510	1.50	YSAF	77	132S-4	91
118	410	12.07	6500	1.75				
134	365	10.65	6450	2.0				
151	325	9.44	6390	2.2				
177	275	8.06	6280	2.5				
130	370	11.03	2930	0.90	YS	67	132S-4	64
143	340	10.03	3260	1.00	YSF	67	132S-4	70
165	295	8.69	3670	1.15	YSA	67	132S-4	65
189	255	7.56	3850	1.15	YSAF	67	132S-4	69

<b>P<sub>1</sub> = 7.5 kW</b>								
-------------------------------	--	--	--	--	--	--	--	--

14	4160	105.71	32900	0.85				
16	3560	89.60	34100	0.90				
18	3130	78.26	34800	1.00				
20	3200	71.43	34600	1.05				
22	2630	65.45	35500	1.10				
24	2730	60.59	35300	1.20				
26	2520	55.79	35600	1.30	YS	97	132M-4	200
29	2260	49.87	35900	1.45	YSF	97	132M-4	230
32	2040	44.89	36100	1.60	YSA	97	132M-4	195
35	1850	40.65	36300	1.80	YSAF	97	132M-4	220
40	1650	36.05	36200	2.0				
44	1490	32.60	35500	2.2				
54	1240	26.39	32000	2.1				
61	1110	23.59	31400	2.3				
67	1000	21.23	30700	2.6				
74	910	19.23	30100	2.9				
32	1970	44.03	27800	0.80	YS	87	132M-4	140
37	1750	39.10	27400	0.90	YSF	87	132M-4	165
41	1570	34.96	27000	1.00	YSA	87	132M-4	140
					YSAF	87	132M-4	155



技术参数

Technical Data

<b>P<sub>1</sub> = 7.5 kW</b>								
-------------------------------	--	--	--	--	--	--	--	--

N <sub>A</sub> rpm	M <sub>2</sub> Nm	i	Fr <sub>2</sub> MAX[N]	f <sub>s</sub>	Type	Gear unit	Motor size	Kg
45	1420	31.43	26500	1.15				
52	1230	27.28	25900	1.30				
56	1180	25.50	23500	1.05				
67	1000	21.43	23000	1.25				
73	920	19.70	22700	1.35	YS	87	132M-4	140
82	820	17.49	22300	1.50	YSF	87	132M-4	165
91	730	15.64	21900	1.70	YSA	87	132M-4	140
102	660	14.06	21500	1.90	YSAF	87	132M-4	155
117	575	12.21	20900	2.2				
131	515	10.93	20500	2.4				
158	430	9.07	19700	2.7				
181	375	7.88	19100	2.7				
<hr/>								
50	1260	28.41	6240	0.85	YS	77	132M-4	105
57	1110	25.07	6450	0.90	YSF	77	132M-4	115
64	990	22.22	6600	1.00	YSA	77	132M-4	105
78	850	18.42	1860	0.85	YSAF	77	132M-4	110
<hr/>								
82	810	17.45	2290	0.90				
94	705	15.28	3250	1.00	YS	77	132M-4	105
104	640	13.76	3890	1.10	YSF	77	132M-4	115
118	560	12.07	4570	1.30	YSA	77	132M-4	105
134	495	10.65	5110	1.45	YSAF	77	132M-4	110
151	440	9.44	5540	1.65				
177	380	8.06	5560	1.80				

<b>P<sub>1</sub> = 11.0 kW</b>								
--------------------------------	--	--	--	--	--	--	--	--

26	3670	55.79	33800	0.90				
29	3290	49.87	34500	1.00				
32	2970	44.89	34800	1.10				
35	2700	40.65	34400	1.20				
40	2400	36.05	33800	1.40				
44	2170	32.60	33300	1.45	YS	97	160M-4	215
55	1810	26.39	29400	1.45	YSF	97	160M-4	245
61	1620	23.59	29000	1.60	YSA	97	160M-4	210
68	1460	21.23	28600	1.80	YSAF	97	160M-4	235
75	1320	19.23	28200	1.95				
84	1180	17.05	27600	2.2				
93	1070	15.42	27200	2.3				
110	900	13.07	26400	2.6				
126	790	11.41	25700	2.8				
<hr/>								
53	1800	27.28	23700	0.90	YS	87	160M-4	155
59	1610	24.43	23400	1.00	YSF	87	160M-4	175
71	1340	20.27	22800	1.20	YSA	87	160M-4	150
					YSAF	87	160M-4	170



技术参数

Technical Data

<b>P<sub>1</sub> = 11.0kW</b>								
-------------------------------	--	--	--	--	--	--	--	--

N <sub>A</sub> rpm	M <sub>2</sub> Nm	i	Fr <sub>2</sub> MAX[N]	f <sub>s</sub>	Type	Gear unit	Motor size	Kg
73	1340	19.70	20400	0.95				
82	1190	17.49	20200	1.05				
92	1070	15.64	20000	1.15	YS	87	160M-4	155
102	960	14.06	19800	1.30	YSF	87	160M-4	175
118	840	12.21	19400	1.50	YSA	87	160M-4	150
132	750	10.93	19100	1.65	YSAF	87	160M-4	170
159	625	9.07	18600	1.85				
183	545	7.88	18100	1.85				

<b>P<sub>1</sub> = 15.0 kW</b>								
--------------------------------	--	--	--	--	--	--	--	--

33	4000	44.89	31400	0.85	YS	97	160L-4	255
36	3630	40.65	31300	0.90	YSF	97	160L-4	285
41	3230	36.05	31000	1.00	YSA	97	160L-4	250
					YSAF	97	160L-4	275
45	2920	32.60	30800	1.10				
55	2430	26.39	26400	1.05				
62	2180	23.59	26300	1.20				
69	1970	21.23	26200	1.30				
76	1780	19.23	26000	1.45	YS	97	160L-4	255
86	1580	17.05	25700	1.60	YSF	97	160L-4	285
95	1430	15.42	25400	1.70	YSA	97	160L-4	250
112	1220	13.07	24800	1.90	YSAF	97	160L-4	275
128	1060	11.41	24300	2.1				
153	890	9.55	23600	2.3				
177	775	8.26	22900	2.3				
93	1430	15.64	17900	0.85	YS	87	160L-4	195
104	1290	14.06	17900	0.95	YSF	87	160L-4	215
120	1120	12.21	17800	1.10	YSA	87	160L-4	190
					YSAF	87	160L-4	205
134	1010	10.93	17600	1.25	YS	87	160L-4	195
161	840	9.07	17300	1.35	YSF	87	160L-4	215
185	730	7.88	17000	1.40	YSA	87	160L-4	190
					YSAF	87	160L-4	205

<b>P<sub>1</sub> = 18.5 kW</b>								
--------------------------------	--	--	--	--	--	--	--	--

41	3970	36.05	28700	0.85				
45	3590	32.60	28600	0.90	YS	97	180M-4	275
53	3060	27.63	28400	1.00	YSF	97	180M-4	310
61	2680	24.13	28100	1.05	YSA	97	180M-4	270
69	2420	21.23	24100	1.10	YSAF	97	180M-4	295
76	2190	19.23	24100	1.20				



技术参数

Technical Data

<b>P<sub>1</sub> = 18.5kW</b>								
-------------------------------	--	--	--	--	--	--	--	--

N <sub>A</sub> rpm	M <sub>2</sub> Nm	i	Fr <sub>2MAX</sub> [N]	f <sub>s</sub>	Type	Gear unit	Motor size	 Kg
86	1950	17.05	24000	1.30				
95	1760	15.42	23900	1.40	YS	97	180M-4	275
112	1500	13.07	23500	1.55	YSF	97	180M-4	310
128	1310	11.41	23200	1.70	YSA	97	180M-4	270
153	1100	9.55	22600	1.85	YSAF	97	180M-4	295
177	950	8.26	22100	1.85				

<b>P<sub>1</sub> = 22kW</b>								
-----------------------------	--	--	--	--	--	--	--	--

53	3630	27.63	26600	0.85				
61	3180	24.13	26500	0.90	YS	97	180L-4	290
69	2870	21.23	19800	0.90	YSF	97	180L-4	320
76	2600	19.23	21800	1.00	YSA	97	180L-4	285
86	2310	17.05	22300	1.10	YSAF	97	180L-4	310
95	2090	15.42	22400	1.20				
112	1780	13.07	22300	1.30	YS	97	180L-4	290
128	1560	11.41	22100	1.40	YSF	97	180L-4	320
153	1300	9.55	21700	1.55	YSA	97	180L-4	285
177	1130	8.26	21300	1.55	YSAF	97	180L-4	310



安装尺寸

Mounting Dimensions

YS37...

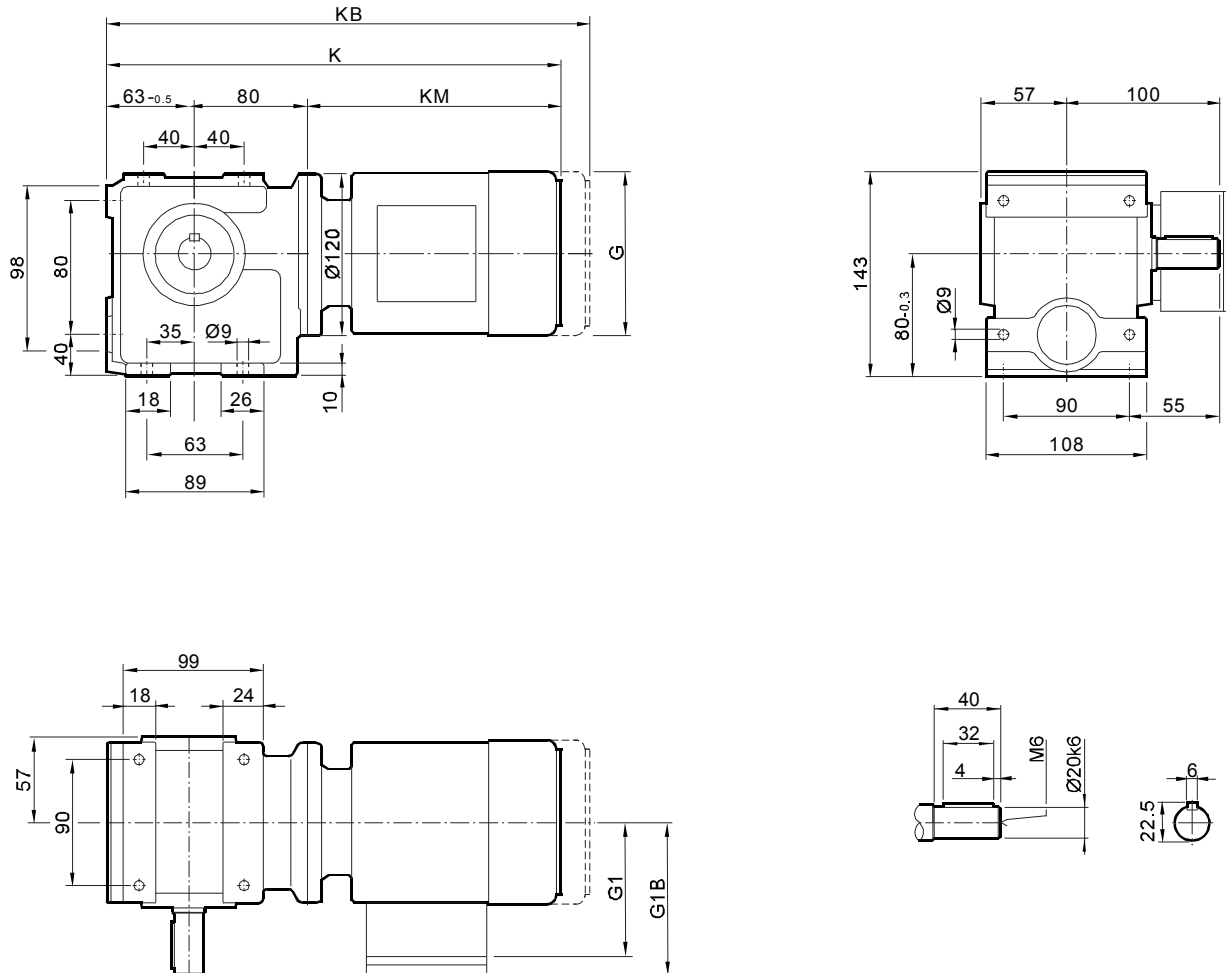

尺寸 Dimensions	电机规格 Motor frame									
	63	71	80	90						
<b>G</b>	132	145	145	197						
<b>G1</b>	99	122	122	154						
<b>G1B</b>	99	127	127	161						
<b>K</b>	334	349	399	419						
<b>KB</b>	389	413	463	504						
<b>KM</b>	191	206	256	276						

尺寸说明

以上尺寸为直联普通电机和制动电机尺寸；  
G1B,KB为制动电机尺寸,其余为普通电机尺寸；  
防爆电机, 辊道电机, 船用电机等须加过渡法兰, 见431页。

ATTENTION

Dimensions of general and brake motor shown in upon table, the others like explosion, roller, or marine motor coupled by adaptor, the dimensions on page 431.



安装尺寸

Mounting Dimensions

YSF37...

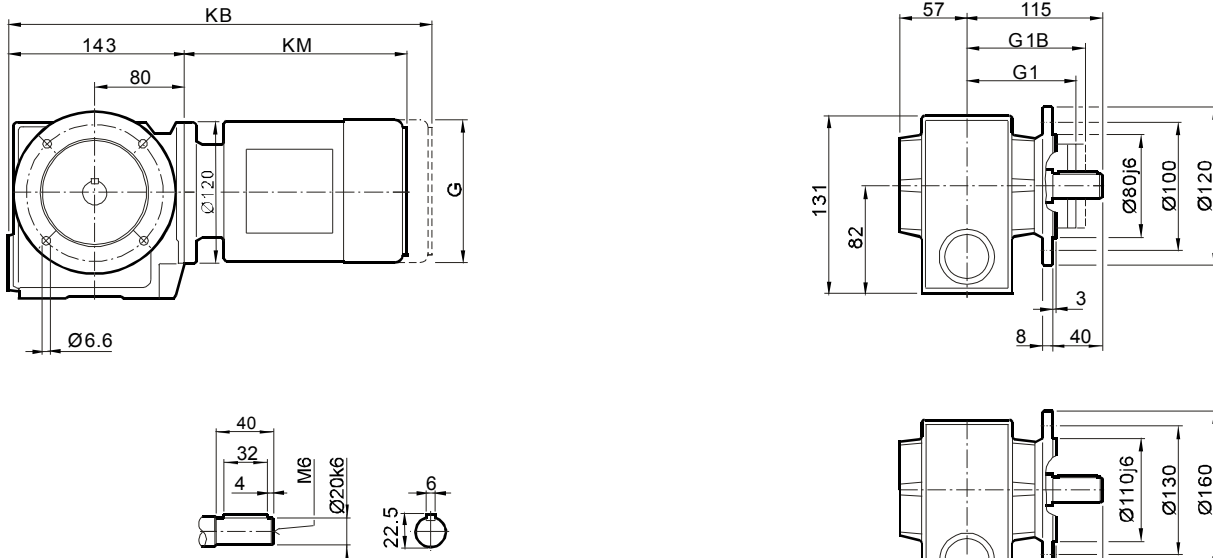

YSAF37...

YSHF37...

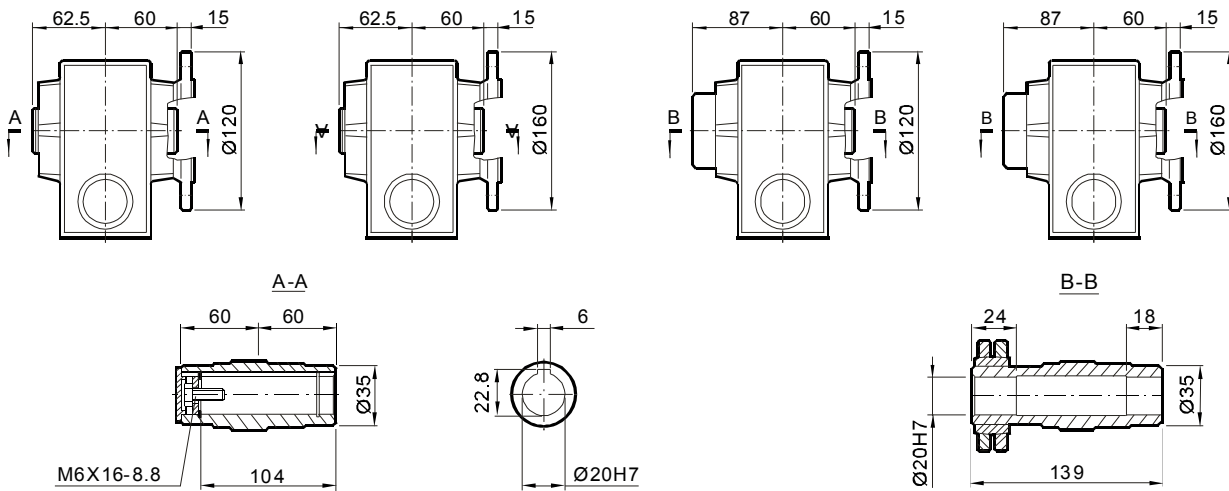

尺寸 Dimensions	电机规格 Motor frame									
	63	71	80	90						
G	132	145	145	197						
G1	99	122	122	154						
G1B	99	127	127	161						
K	334	349	399	419						
KB	389	413	463	504						
KM	191	206	256	276						

尺寸说明

以上尺寸为直联普通电机和制动电机尺寸；  
G1B,KB为制动电机尺寸,其余为普通电机尺寸；  
防爆电机, 辊道电机, 船用电机等须加过渡法兰, 见431页。

ATTENTION

Dimensions of general and brake motor shown in upon table, the others like explosion, roller, or marine motor coupled by adaptor, the dimensions on page 431.



安装尺寸

Mounting Dimensions

**YSA37...**

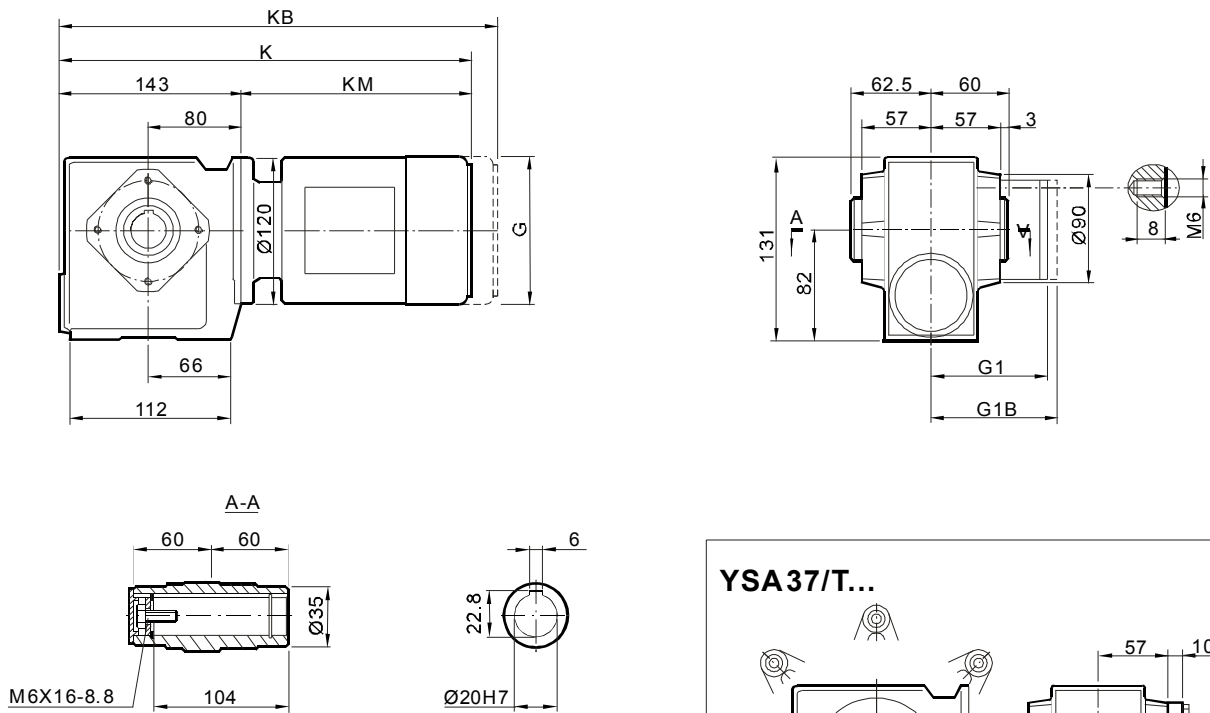

**YSH37...**

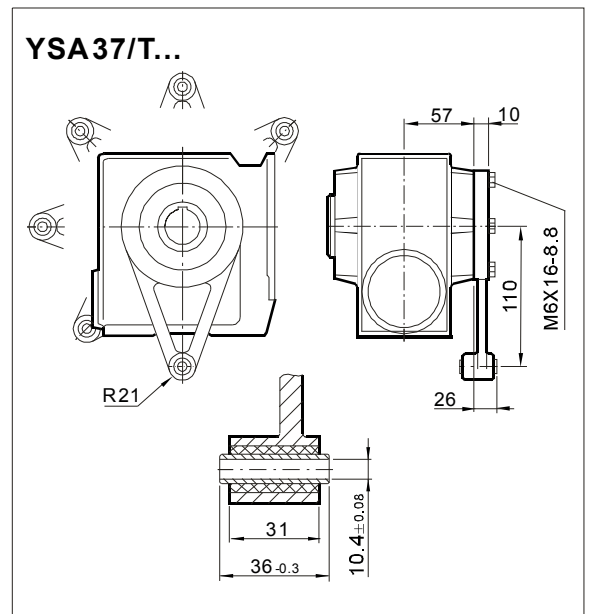
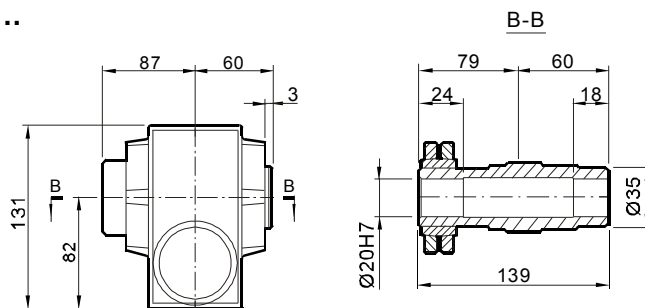

尺寸 Dimensions	电机规格 Motor frame									
	63	71	80	90						
<b>G</b>	132	145	145	197						
<b>G1</b>	99	122	122	154						
<b>G1B</b>	99	127	127	161						
<b>K</b>	334	349	399	419						
<b>KB</b>	389	413	463	504						
<b>KM</b>	191	206	256	276						

尺寸说明

以上尺寸为直联普通电机和制动电机尺寸；  
G1B,KB为制动电机尺寸,其余为普通电机尺寸；  
防爆电机, 辊道电机, 船用电机等须加过渡法兰, 见431页。

**ATTENTION**

Dimensions of general and brake motor shown in upon table, the others like explosion, roller, or marine motor coupled by adaptor, the dimensions on page 431.



安装尺寸

Mounting Dimensions

YS47...

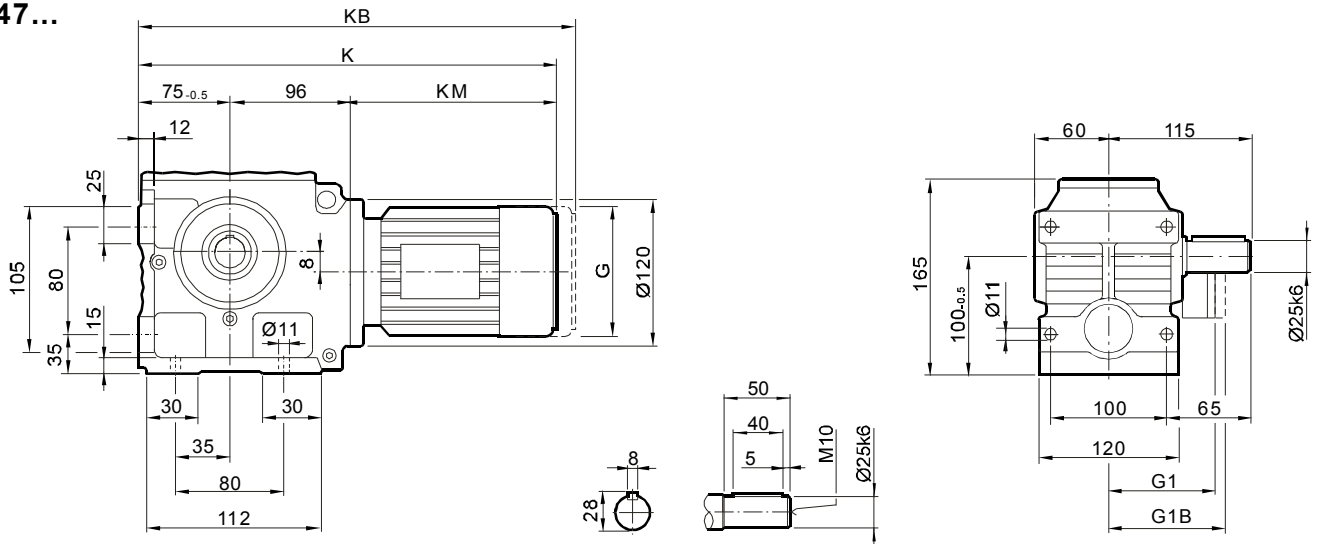

尺寸 Dimensions	电机规格 Motor frame									
	63	71	80	90						
<b>G</b>	132	145	145	197						
<b>G1</b>	99	122	122	154						
<b>G1B</b>	99	127	127	161						
<b>K</b>	362	377	427	447						
<b>KB</b>	417	441	491	532						
<b>KM</b>	191	206	256	276						

尺寸说明

以上尺寸为直联普通电机和制动电机尺寸；  
G1B,KB为制动电机尺寸,其余为普通电机尺寸；  
防爆电机, 辊道电机, 船用电机等须加过渡法兰, 见431页。

ATTENTION

Dimensions of general and brake motor shown in upon table, the others like explosion, roller, or marine motor coupled by adaptor, the dimensions on page 431.



安装尺寸

Mounting Dimensions

YSF47...

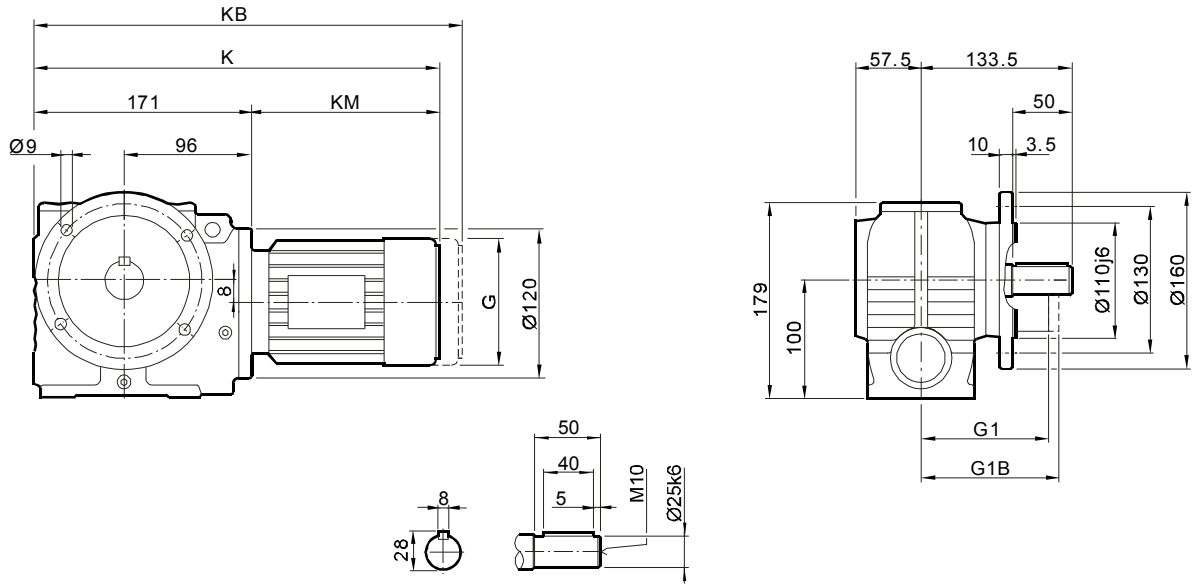

YSAF47...

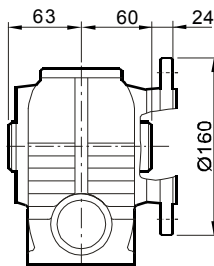

YSHF47...

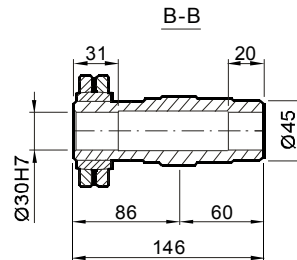
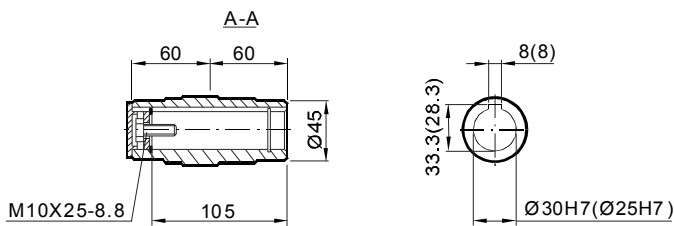
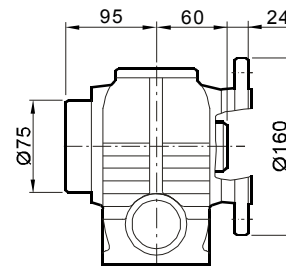

尺寸 Dimensions	电机规格 Motor frame										
	63	71	80	90							
<b>G</b>	132	145	145	197							
<b>G1</b>	99	122	122	154							
<b>G1B</b>	99	127	127	161							
<b>K</b>	362	377	427	447							
<b>KB</b>	417	441	491	532							
<b>KM</b>	191	206	256	276							

尺寸说明

以上尺寸为直联普通电机和制动电机尺寸；  
G1B,KB为制动电机尺寸,其余为普通电机尺寸；  
防爆电机, 辊道电机, 船用电机等须加过渡法兰, 见431页。

ATTENTION

Dimensions of general and brake motor shown in upon table, the others like explosion, roller, or marine motor coupled by adaptor, the dimensions on page 431.



安装尺寸

Mounting Dimensions

**YSA47...**

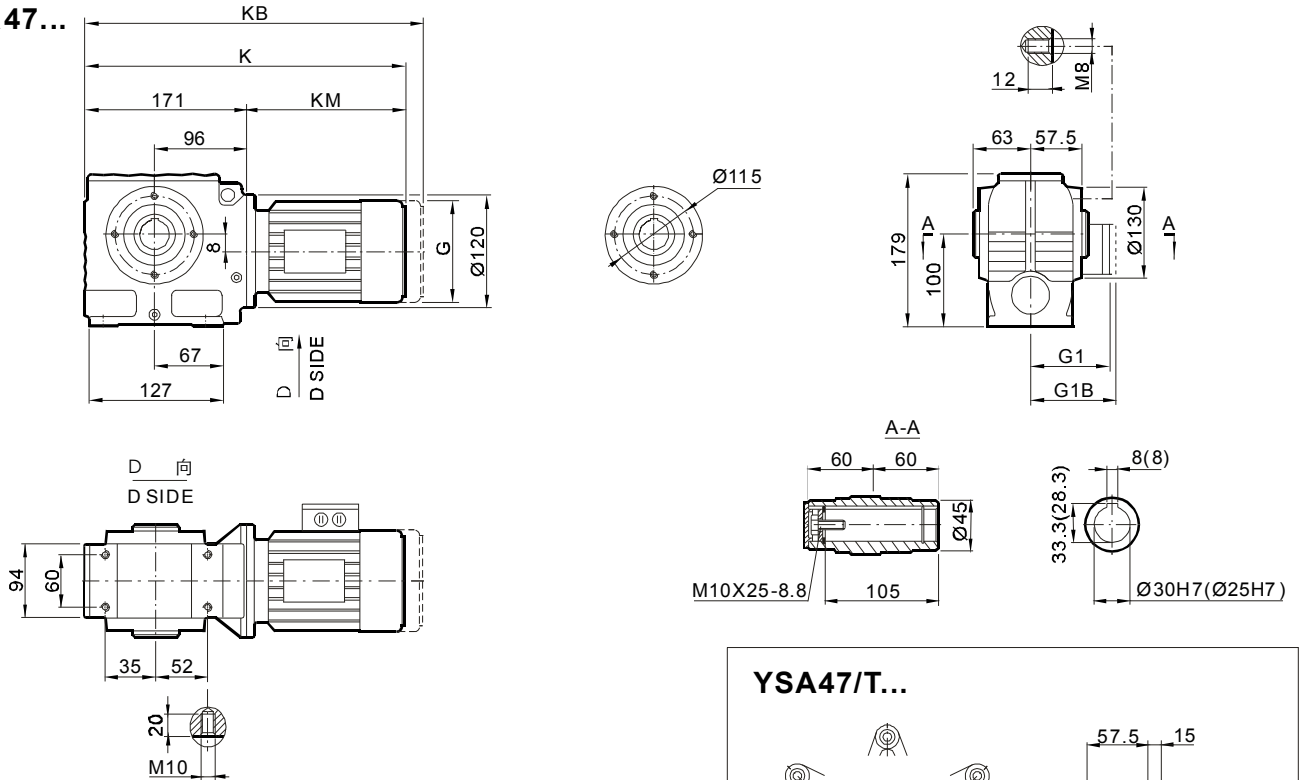

**YSH47...**

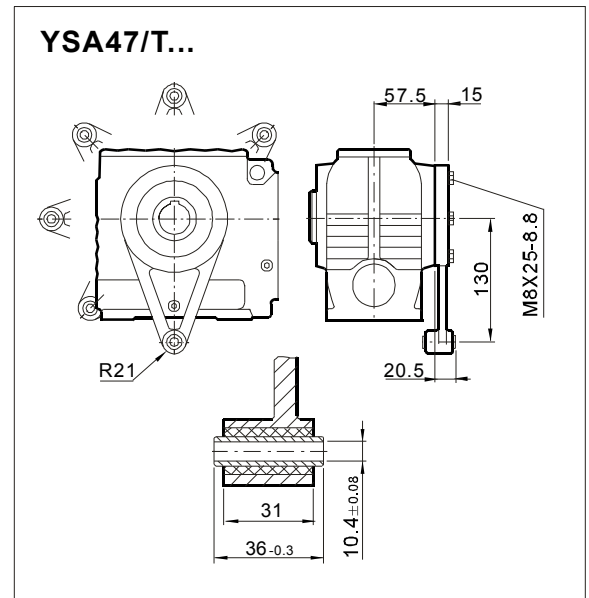
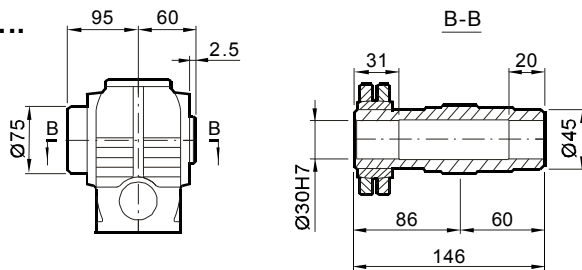

尺寸 Dimensions	电机规格 Motor frame									
	63	71	80	90						
<b>G</b>	132	145	145	197						
<b>G1</b>	99	122	122	154						
<b>G1B</b>	99	127	127	161						
<b>K</b>	362	377	427	447						
<b>KB</b>	417	441	491	532						
<b>KM</b>	191	206	256	276						

尺寸说明

以上尺寸为直联普通电机和制动电机尺寸；  
G1B,KB为制动电机尺寸,其余为普通电机尺寸；  
防爆电机, 辊道电机, 船用电机等须加过渡法兰, 见431页。

**ATTENTION**

Dimensions of general and brake motor shown in upon table, the others like explosion, roller, or marine motor coupled by adaptor, the dimensions on page 431.



安装尺寸

Mounting Dimensions

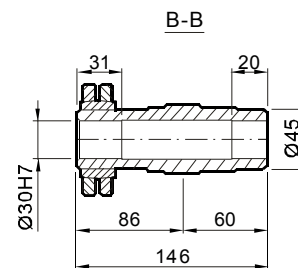
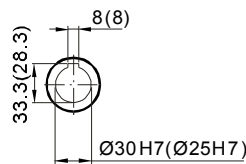
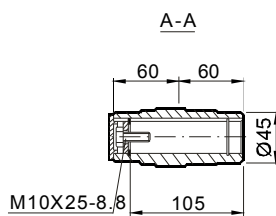
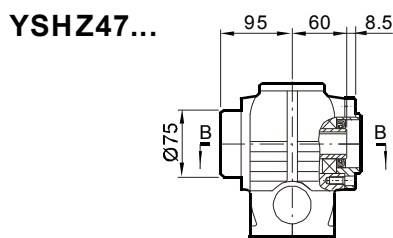
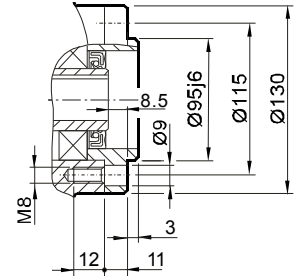
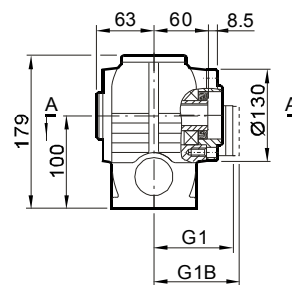
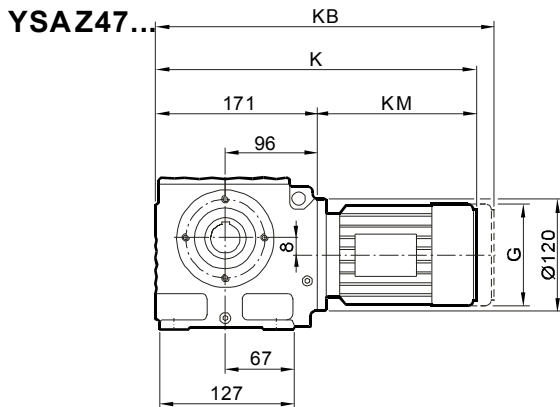

尺寸 Dimensions	电机规格 Motor frame									
	63	71	80	90						
<b>G</b>	132	145	145	197						
<b>G1</b>	99	122	122	154						
<b>G1B</b>	99	127	127	161						
<b>K</b>	362	377	427	447						
<b>KB</b>	417	441	491	532						
<b>KM</b>	191	206	256	276						

尺寸说明

以上尺寸为直联普通电机和制动电机尺寸；  
G1B,KB为制动电机尺寸,其余为普通电机尺寸；  
防爆电机, 辊道电机, 船用电机等须加过渡法兰, 见431页。

ATTENTION

Dimensions of general and brake motor shown in upon table, the others like explosion, roller, or marine motor coupled by adaptor, the dimensions on page 431.



安装尺寸

Mounting Dimensions

YS57...

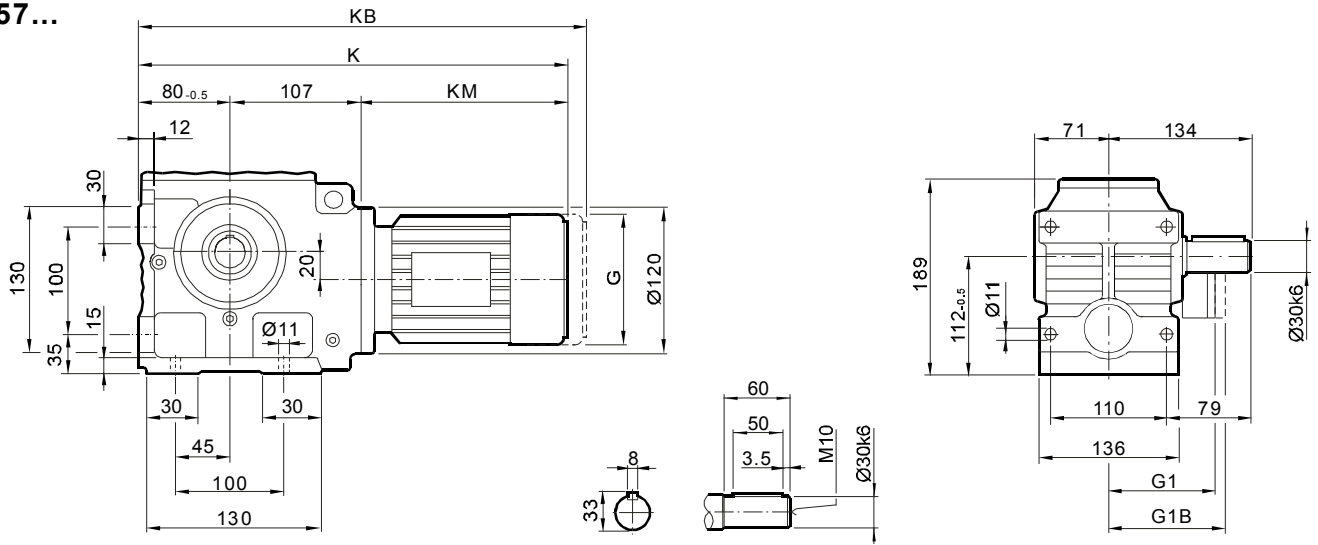

尺寸 Dimensions	电机规格 Motor frame										
	63	71	80	90	100M	100L					
<b>G</b>	132	145	145	197	197	197					
<b>G1</b>	105	122	122	154	166	166					
<b>G1B</b>	105	127	127	161	166	166					
<b>K</b>	378	393	443	463	515	545					
<b>KB</b>	433	456	506	548	600	630					
<b>KM</b>	191	206	256	276	328	358					

尺寸说明

以上尺寸为直联普通电机和制动电机尺寸；  
G1B,KB为制动电机尺寸,其余为普通电机尺寸；  
防爆电机, 辊道电机, 船用电机等须加过渡法兰, 见431页。

ATTENTION

Dimensions of general and brake motor shown in upon table, the others like explosion, roller, or marine motor coupled by adaptor, the dimensions on page 431.



安装尺寸

Mounting Dimensions

YSF57...

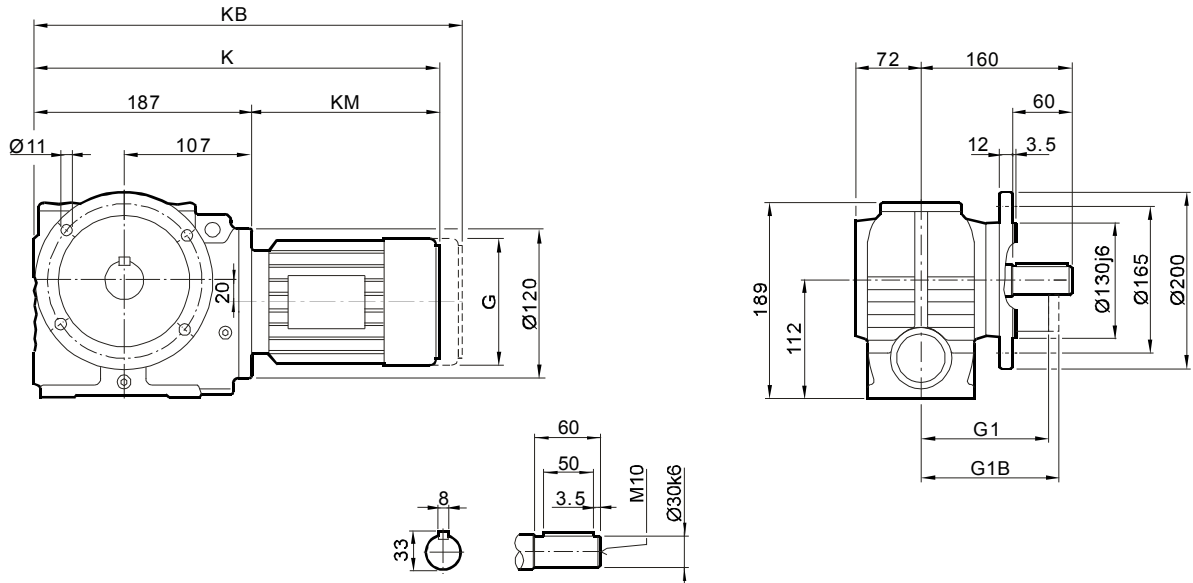

YSAF57...

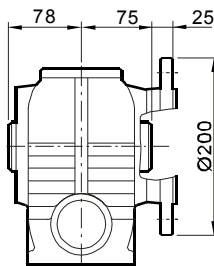

YSHF57...

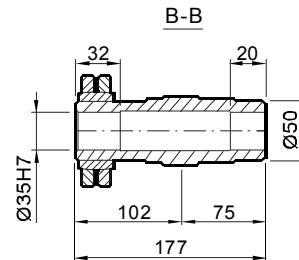
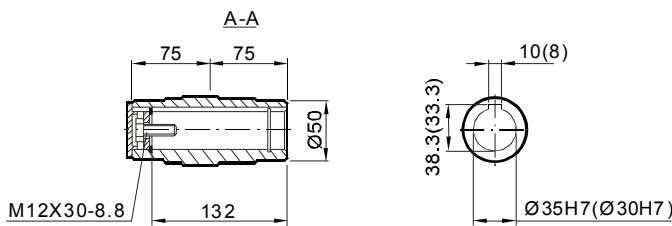
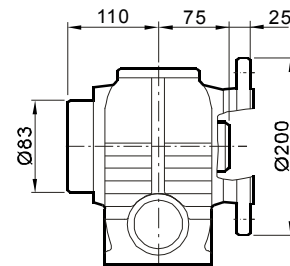

尺寸 Dimensions	电机规格 Motor frame										
	63	71	80	90	100M	100L					
<b>G</b>	132	145	145	197	197	197					
<b>G1</b>	105	122	122	154	166	166					
<b>G1B</b>	105	127	127	161	166	166					
<b>K</b>	378	393	443	463	515	545					
<b>KB</b>	433	456	506	548	600	630					
<b>KM</b>	191	206	256	276	328	358					

尺寸说明

以上尺寸为直联普通电机和制动电机尺寸；  
G1B,KB为制动电机尺寸,其余为普通电机尺寸；  
防爆电机, 辊道电机, 船用电机等须加过渡法兰, 见431页。

ATTENTION

Dimensions of general and brake motor shown in upon table, the others like explosion, roller, or marine motor coupled by adaptor, the dimensions on page 431.



安装尺寸

Mounting Dimensions

**YSA57...**

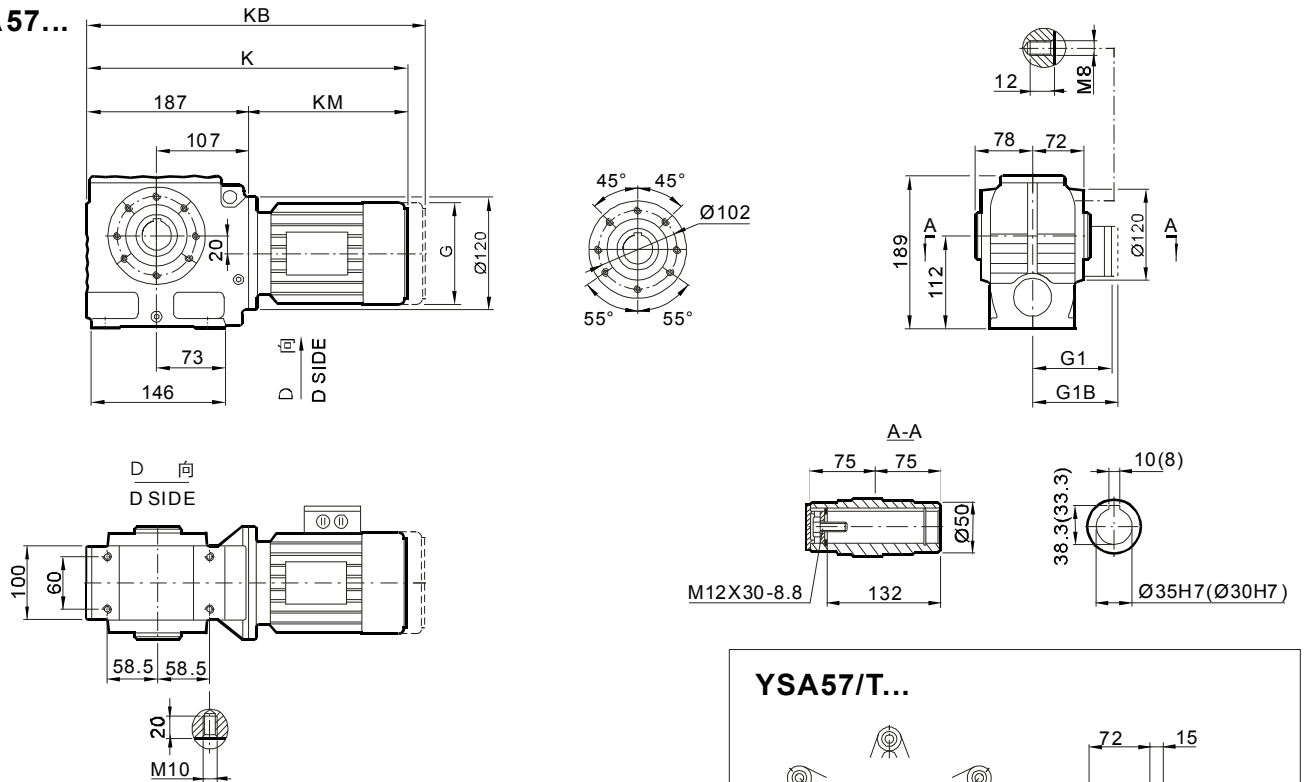

**YSH57...**

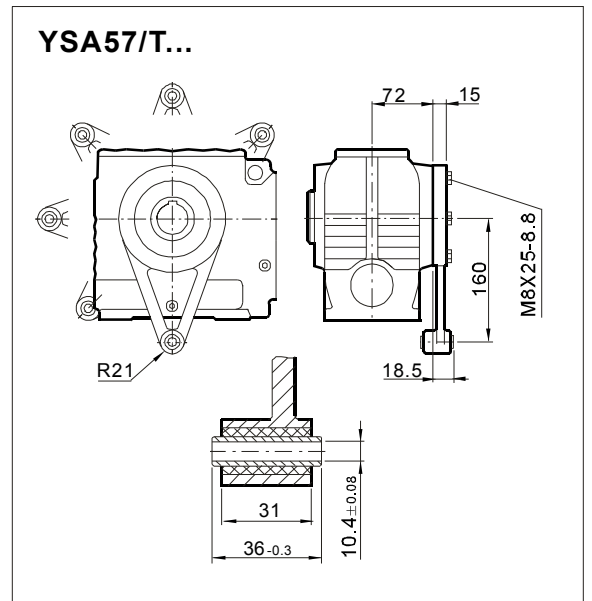
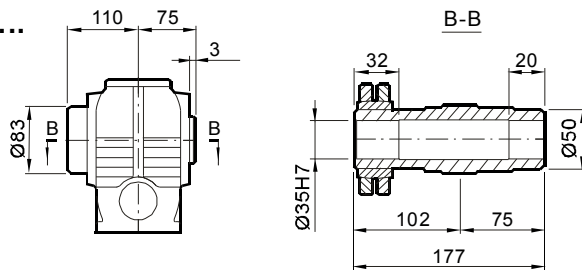

尺寸 Dimensions	电机规格 Motor frame											
	63	71	80	90	100M	100L						
<b>G</b>	132	145	145	197	197	197						
<b>G1</b>	105	122	122	154	166	166						
<b>G1B</b>	105	127	127	161	166	166						
<b>K</b>	378	393	443	463	515	545						
<b>KB</b>	433	456	506	548	600	630						
<b>KM</b>	191	206	256	276	328	358						

尺寸说明

以上尺寸为直联普通电机和制动电机尺寸；  
G1B,KB为制动电机尺寸,其余为普通电机尺寸；  
防爆电机, 辊道电机, 船用电机等须加过渡法兰, 见431页。

ATTENTION

Dimensions of general and brake motor shown in upon table, the others like explosion, roller, or marine motor coupled by adaptor, the dimensions on page 431.



安装尺寸

Mounting Dimensions

YSAZ57...

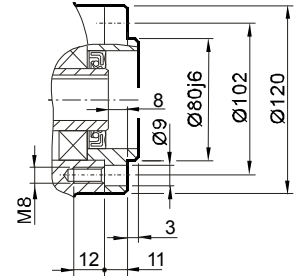
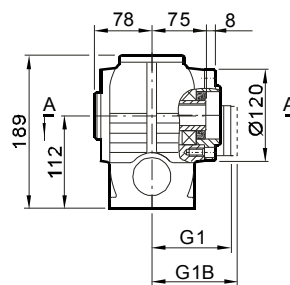
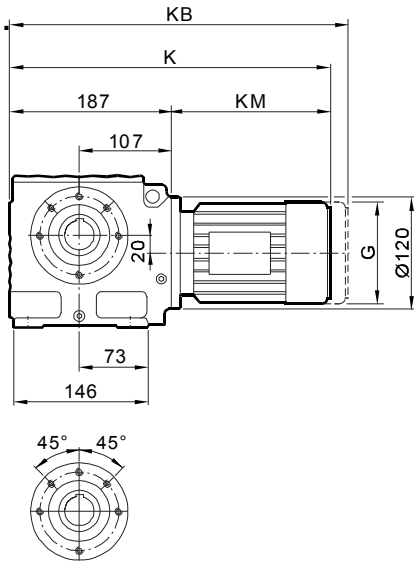

YSHZ57...

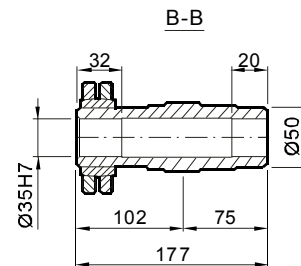
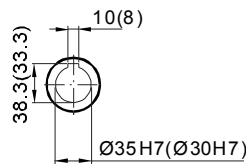
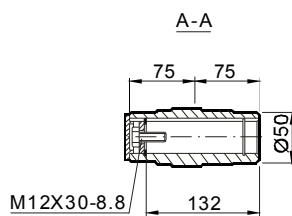
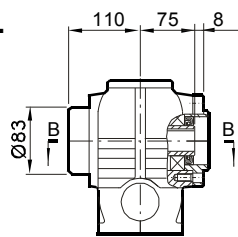

尺寸 Dimensions	电机规格 Motor frame									
	63	71	80	90	100M	100L				
G	132	145	145	197	197	197				
G1	105	122	122	154	166	166				
G1B	105	127	127	161	166	166				
K	378	393	443	463	515	545				
KB	433	456	506	548	600	630				
KM	191	206	256	276	328	358				

尺寸说明

以上尺寸为直联普通电机和制动电机尺寸；  
G1B,KB为制动电机尺寸,其余为普通电机尺寸；  
防爆电机, 辊道电机, 船用电机等须加过渡法兰, 见431页。

ATTENTION

Dimensions of general and brake motor shown in upon table, the others like explosion, roller, or marine motor coupled by adaptor, the dimensions on page 431.



安装尺寸

Mounting Dimensions

YS67...

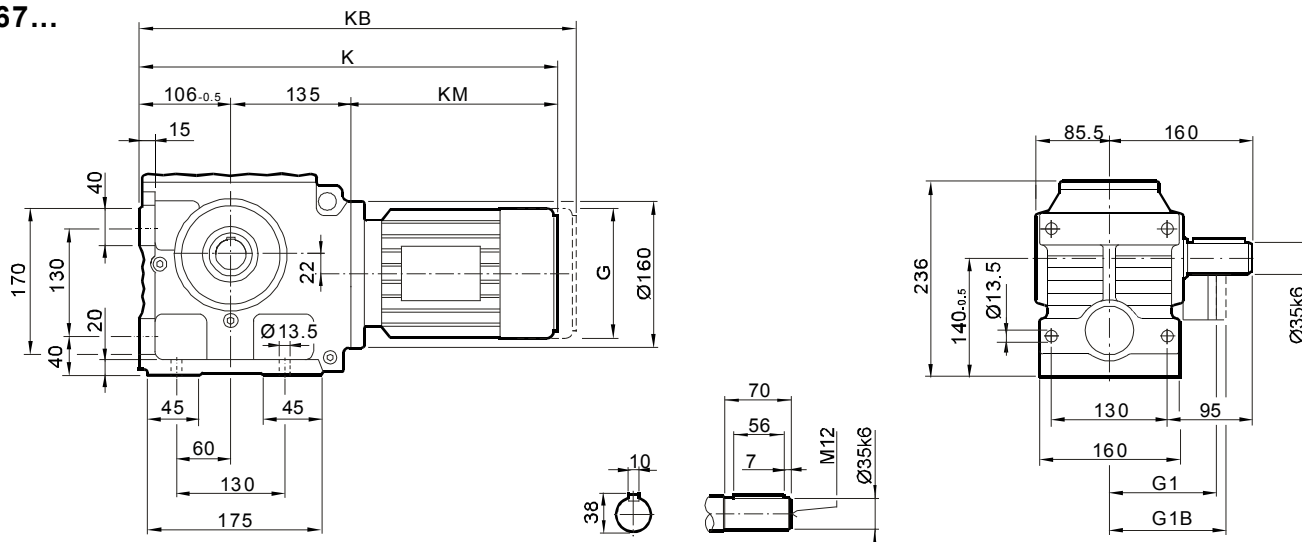

尺寸 Dimensions	电机规格 Motor frame								
	63	71	80	90	100M	100L	112M	132S	
<b>G</b>	132	145	145	197	197	197	221	221	
<b>G1</b>	105	122	122	154	166	166	179	179	
<b>G1B</b>	105	127	127	161	166	166	182	182	
<b>K</b>	427	441	491	511	561	591	596	644	
<b>KB</b>	482	505	555	596	646	676	676	724	
<b>KM</b>	185	199	249	269	319	349	354	402	

尺寸说明

以上尺寸为直联普通电机和制动电机尺寸；  
G1B,KB为制动电机尺寸,其余为普通电机尺寸；  
防爆电机, 辊道电机, 船用电机等须加过渡法兰, 见431页。

ATTENTION

Dimensions of general and brake motor shown in upon table, the others like explosion, roller, or marine motor coupled by adaptor, the dimensions on page 431.



安装尺寸

Mounting Dimensions

YSF67...

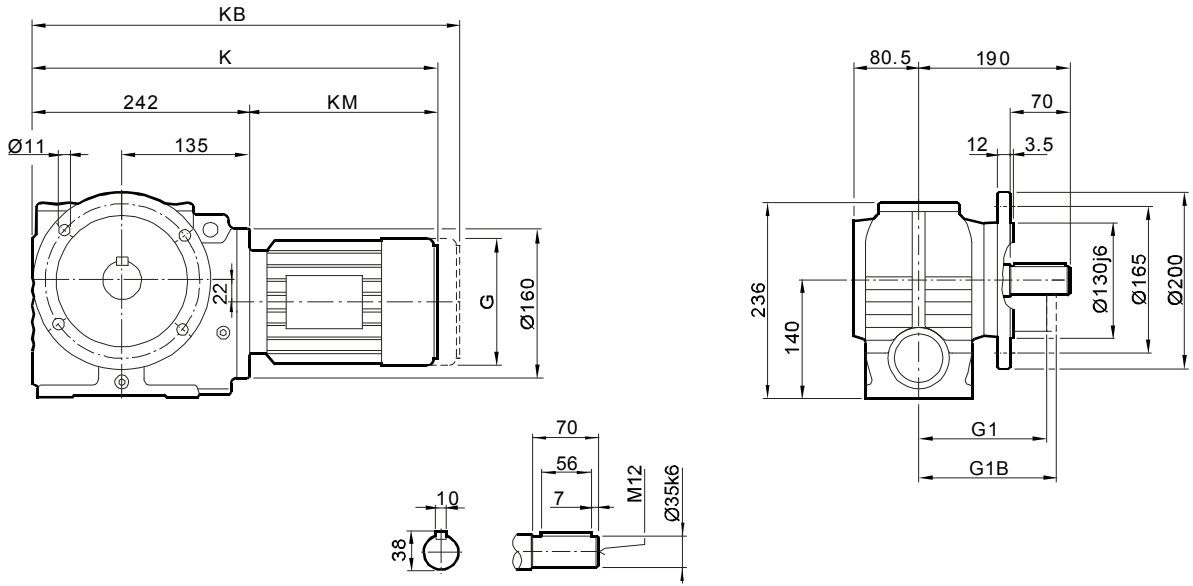

YSAF67...

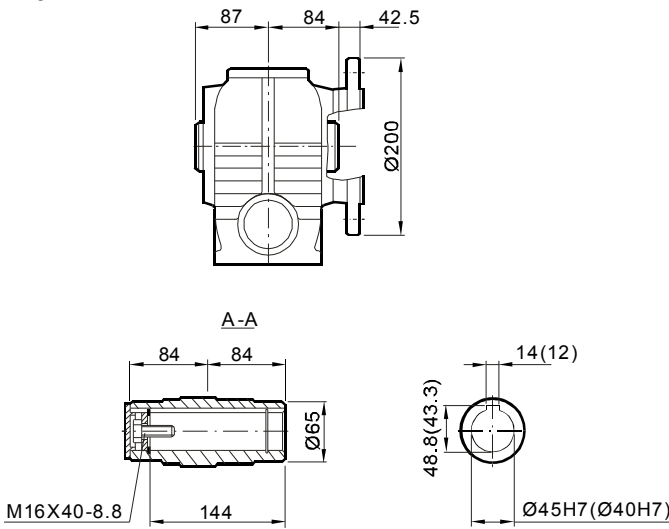

YSHF67...

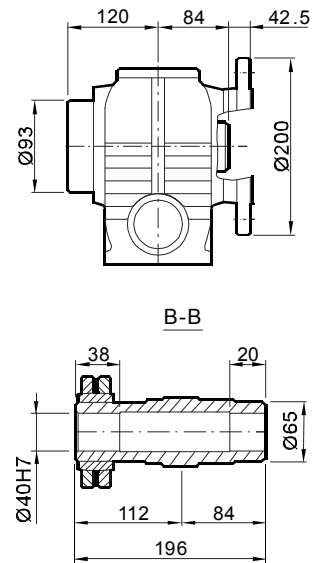

尺寸 Dimensions	电机规格 Motor frame								
	63	71	80	90	100M	100L	112M	132S	
G	132	145	145	197	197	197	221	221	
G1	105	122	122	154	166	166	179	179	
G1B	105	127	127	161	166	166	182	182	
K	427	441	491	511	561	591	596	644	
KB	482	505	555	596	646	676	676	724	
KM	185	199	249	269	319	349	354	402	

尺寸说明

以上尺寸为直联普通电机和制动电机尺寸；  
G1B,KB为制动电机尺寸,其余为普通电机尺寸；  
防爆电机，辊道电机，船用电机等须加过渡法兰，见431页。

ATTENTION

Dimensions of general and brake motor shown in upon table, the others like explosion, roller, or marine motor coupled by adaptor, the dimensions on page 431.



安装尺寸

Mounting Dimensions

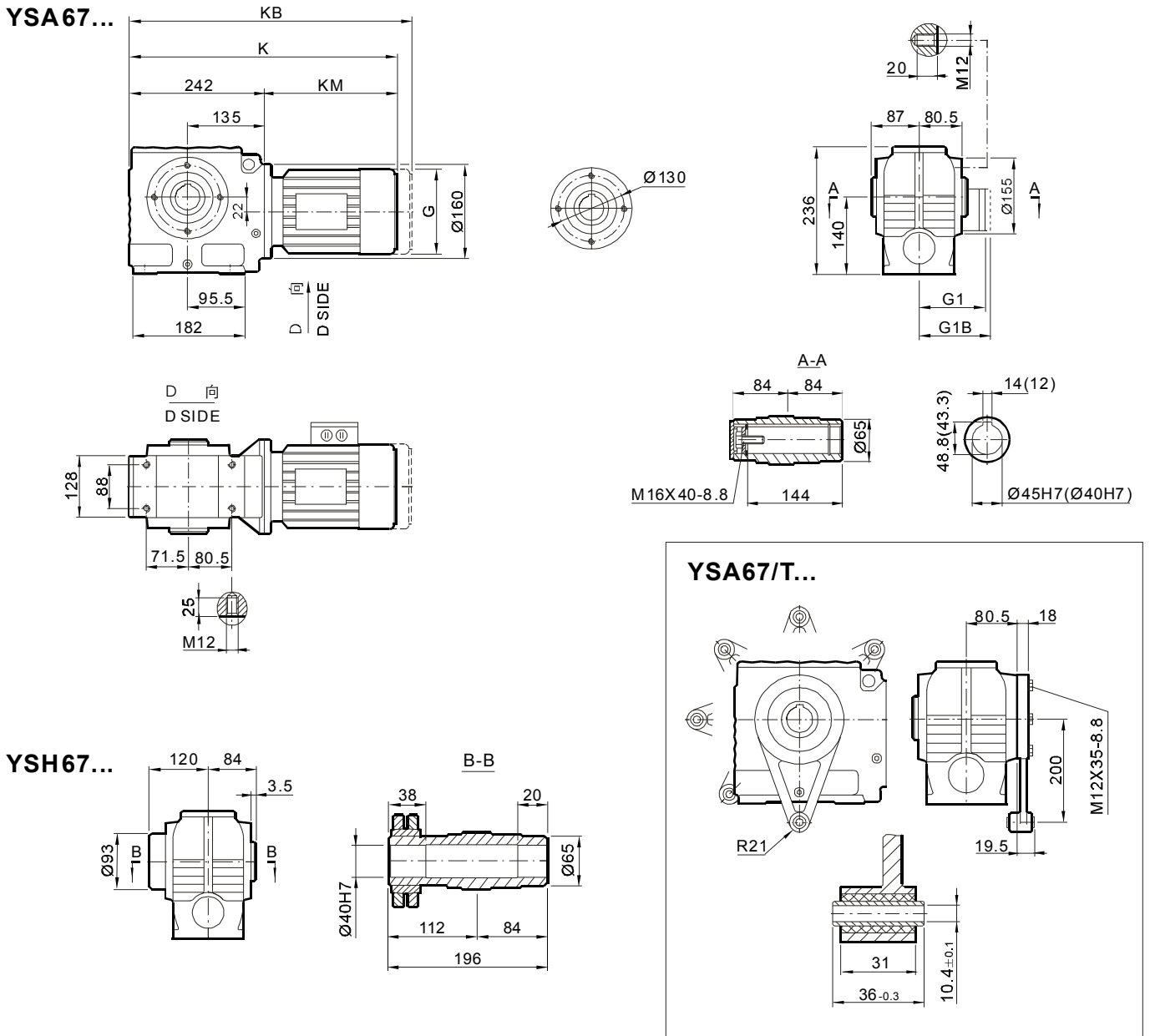

尺寸 Dimensions	电机规格 Motor frame										
	63	71	80	90	100M	100L	112M	132S			
<b>G</b>	132	145	145	197	197	197	221	221			
<b>G1</b>	105	122	122	154	166	166	179	179			
<b>G1B</b>	105	127	127	161	166	166	182	182			
<b>K</b>	427	441	491	511	561	591	596	644			
<b>KB</b>	482	505	555	596	646	676	676	724			
<b>KM</b>	185	199	249	269	319	349	354	402			

尺寸说明

以上尺寸为直联普通电机和制动电机尺寸；  
G1B,KB为制动电机尺寸,其余为普通电机尺寸；  
防爆电机, 辊道电机, 船用电机等须加过渡法兰, 见431页。

ATTENTION

Dimensions of general and brake motor shown in upon table, the others like explosion, roller, or marine motor coupled by adaptor, the dimensions on page 431.



安装尺寸

Mounting Dimensions

**YSAZ67...**

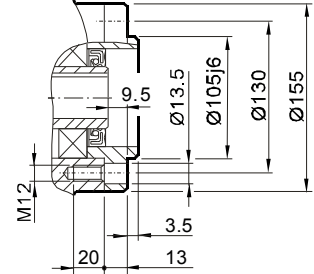
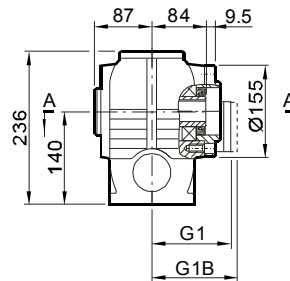
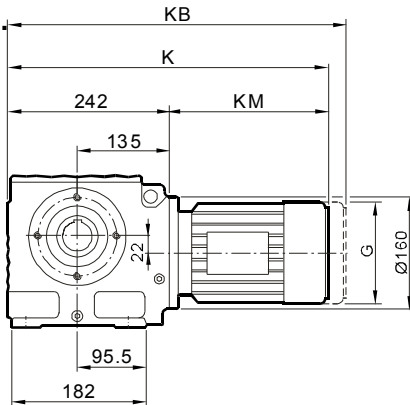

**YSHZ67...**

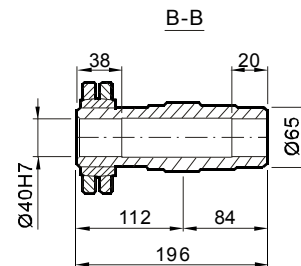
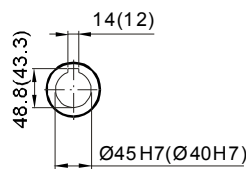
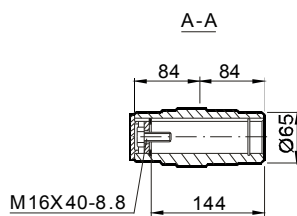
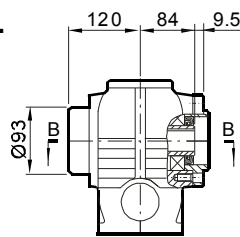

尺寸 Dimensions	电机规格 Motor frame								
	63	71	80	90	100M	100L	112M	132S	
<b>G</b>	132	145	145	197	197	197	221	221	
<b>G1</b>	105	122	122	154	166	166	179	179	
<b>G1B</b>	105	127	127	161	166	166	182	182	
<b>K</b>	427	441	491	511	561	591	596	644	
<b>KB</b>	482	505	555	596	646	676	676	724	
<b>KM</b>	185	199	249	269	319	349	354	402	

尺寸说明

以上尺寸为直联普通电机和制动电机尺寸；  
G1B,KB为制动电机尺寸,其余为普通电机尺寸；  
防爆电机, 辊道电机, 船用电机等须加过渡法兰, 见431页。

**ATTENTION**

Dimensions of general and brake motor shown in upon table, the others like explosion, roller, or marine motor coupled by adaptor, the dimensions on page 431.



安装尺寸

Mounting Dimensions

YS77...

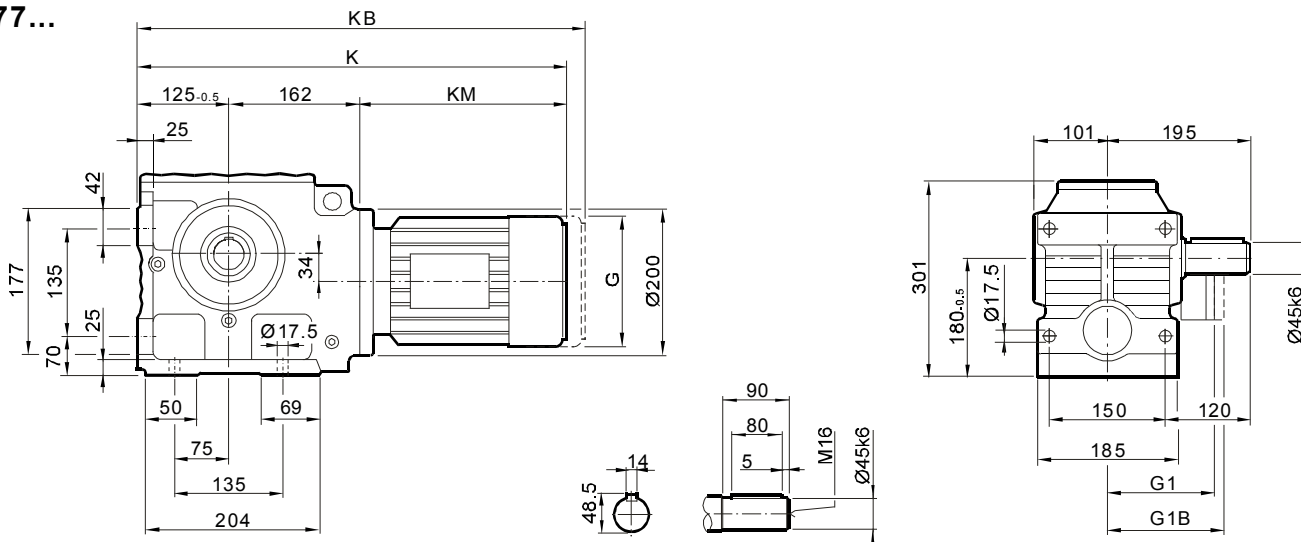

尺寸 Dimensions	电机规格 Motor frame								
	80	90	100M	100L	112M	132S	132M		
<b>G</b>	145	197	197	197	221	221	275		
<b>G1</b>	122	154	166	166	179	179	230		
<b>G1B</b>	127	161	166	166	182	182	230		
<b>K</b>	530	548	598	628	632	677	699		
<b>KB</b>	594	633	683	713	712	757	811		
<b>KM</b>	243	261	311	341	345	390	412		

尺寸说明

以上尺寸为直联普通电机和制动电机尺寸；  
G1B,KB为制动电机尺寸,其余为普通电机尺寸；  
防爆电机，辊道电机，船用电机等须加过渡法兰，见431页。

ATTENTION

Dimensions of general and brake motor shown in upon table, the others like explosion, roller, or marine motor coupled by adaptor, the dimensions on page 431.



安装尺寸

Mounting Dimensions

YSF77...

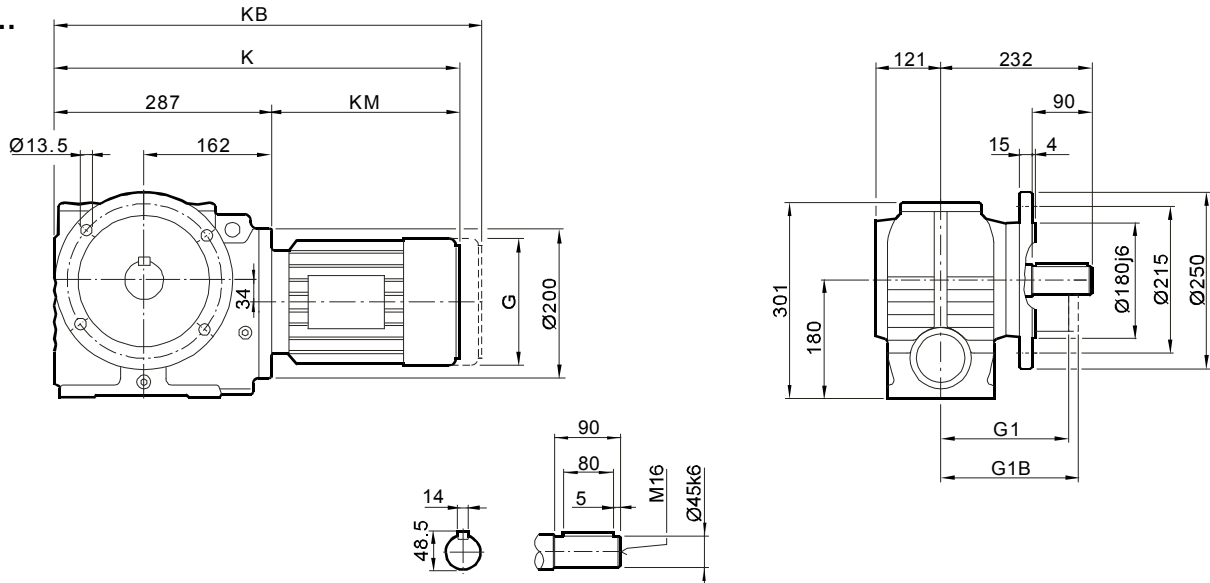

YSAF77...

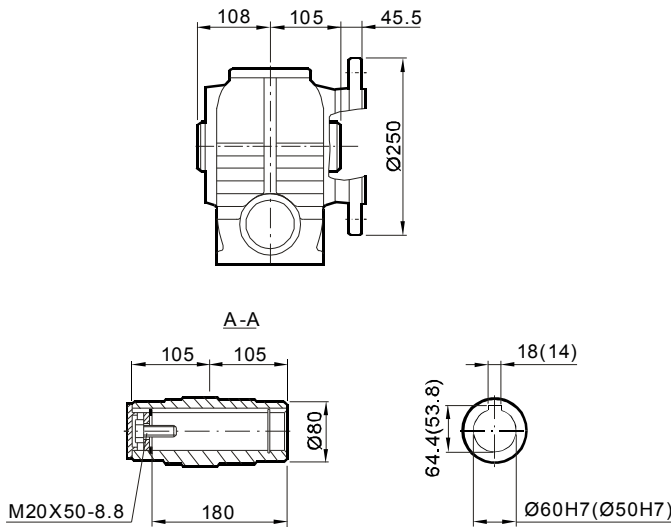

YSHF77...

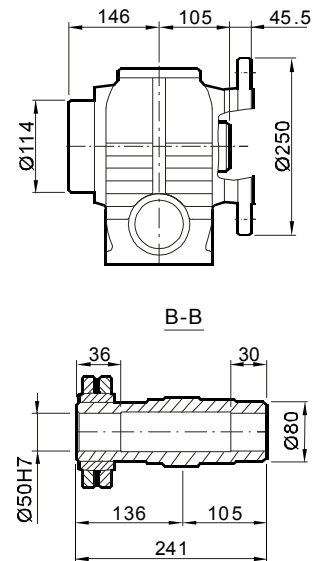

尺寸 Dimensions	电机规格 Motor frame										
	80	90	100M	100L	112M	132S	132M				
G	145	197	197	197	221	221	275				
G1	122	154	166	166	179	179	230				
G1B	127	161	166	166	182	182	230				
K	530	548	598	628	632	677	699				
KB	594	633	683	713	712	757	811				
KM	243	261	311	341	345	390	412				

尺寸说明

以上尺寸为直联普通电机和制动电机尺寸；  
G1B,KB为制动电机尺寸,其余为普通电机尺寸；  
防爆电机，辊道电机，船用电机等须加过渡法兰，见431页。

ATTENTION

Dimensions of general and brake motor shown in upon table, the others like explosion, roller, or marine motor coupled by adaptor, the dimensions on page 431.



安装尺寸

Mounting Dimensions

YSA77...

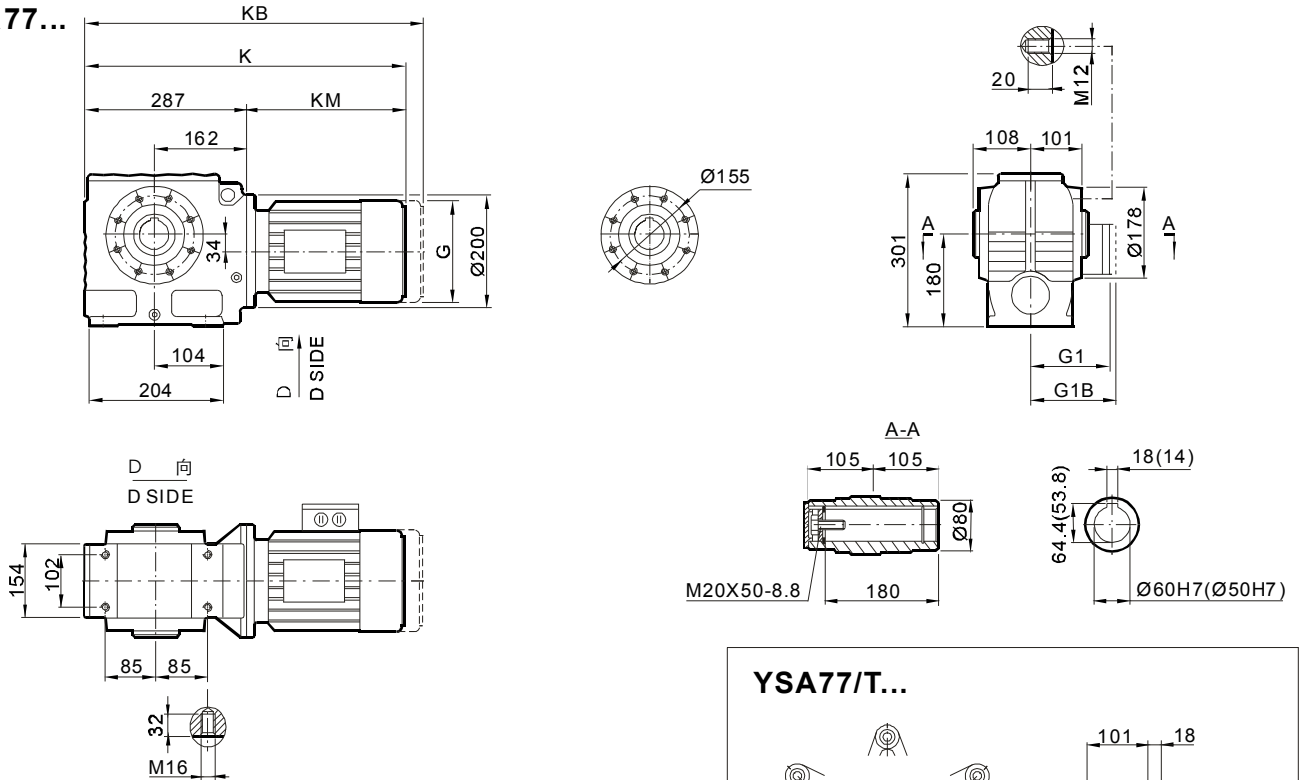

YSH77...

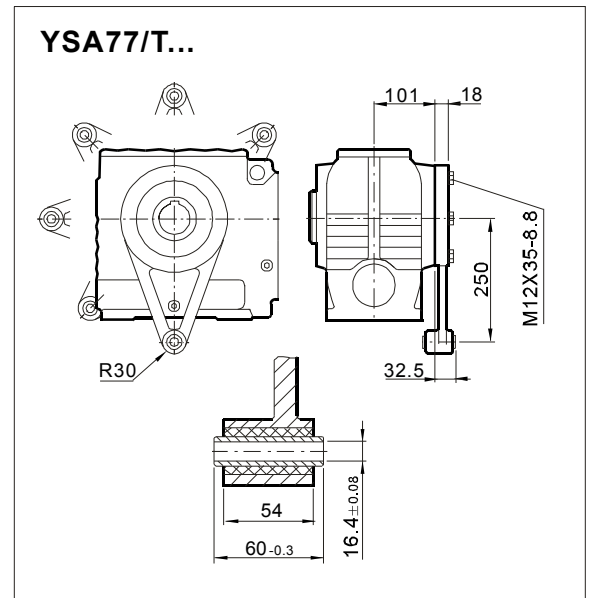
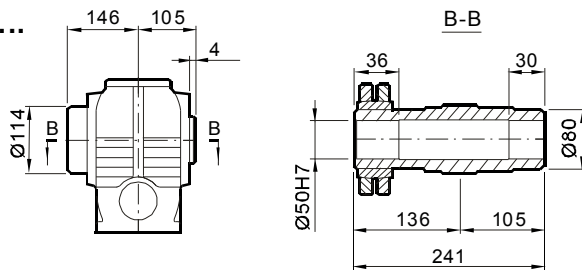

尺寸 Dimensions	电机规格 Motor frame								
	80	90	100M	100L	112M	132S	132M		
G	145	197	197	197	221	221	275		
G1	122	154	166	166	179	179	230		
G1B	127	161	166	166	182	182	230		
K	530	548	598	628	632	677	699		
KB	594	633	683	713	712	757	811		
KM	243	261	311	341	345	390	412		

尺寸说明

以上尺寸为直联普通电机和制动电机尺寸；  
G1B,KB为制动电机尺寸,其余为普通电机尺寸；  
防爆电机, 辊道电机, 船用电机等须加过渡法兰, 见431页。

ATTENTION

Dimensions of general and brake motor shown in upon table, the others like explosion, roller, or marine motor coupled by adaptor, the dimensions on page 431.



安装尺寸

Mounting Dimensions

YSAZ77...

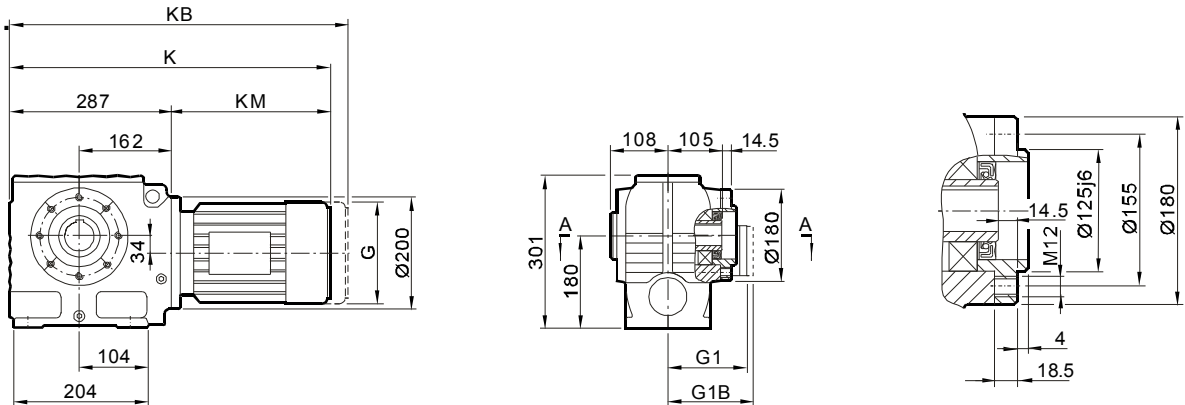

YSHZ77...

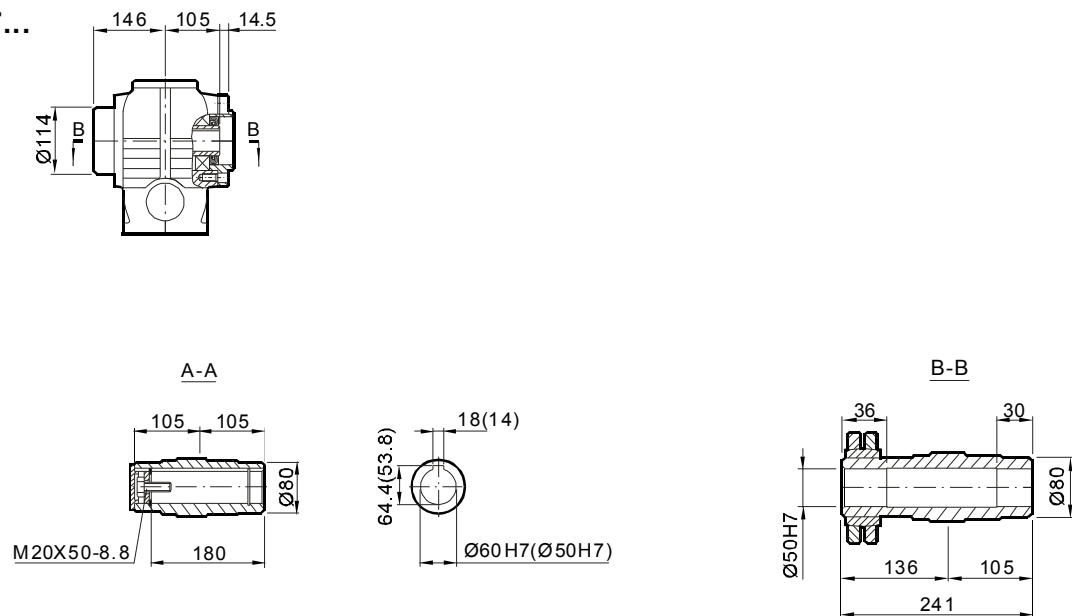

尺寸 Dimensions	电机规格 Motor frame										
	80	90	100M	100L	112M	132S	132M				
<b>G</b>	145	197	197	197	221	221	275				
<b>G1</b>	122	154	166	166	179	179	230				
<b>G1B</b>	127	161	166	166	182	182	230				
<b>K</b>	530	548	598	628	632	677	699				
<b>KB</b>	594	633	683	713	712	757	811				
<b>KM</b>	243	261	311	341	345	390	412				

尺寸说明

以上尺寸为直联普通电机和制动电机尺寸；  
G1B,KB为制动电机尺寸,其余为普通电机尺寸；  
防爆电机, 辊道电机, 船用电机等须加过渡法兰, 见431页。

ATTENTION

Dimensions of general and brake motor shown in upon table, the others like explosion, roller, or marine motor coupled by adaptor, the dimensions on page 431.



安装尺寸

Mounting Dimensions

YS87...

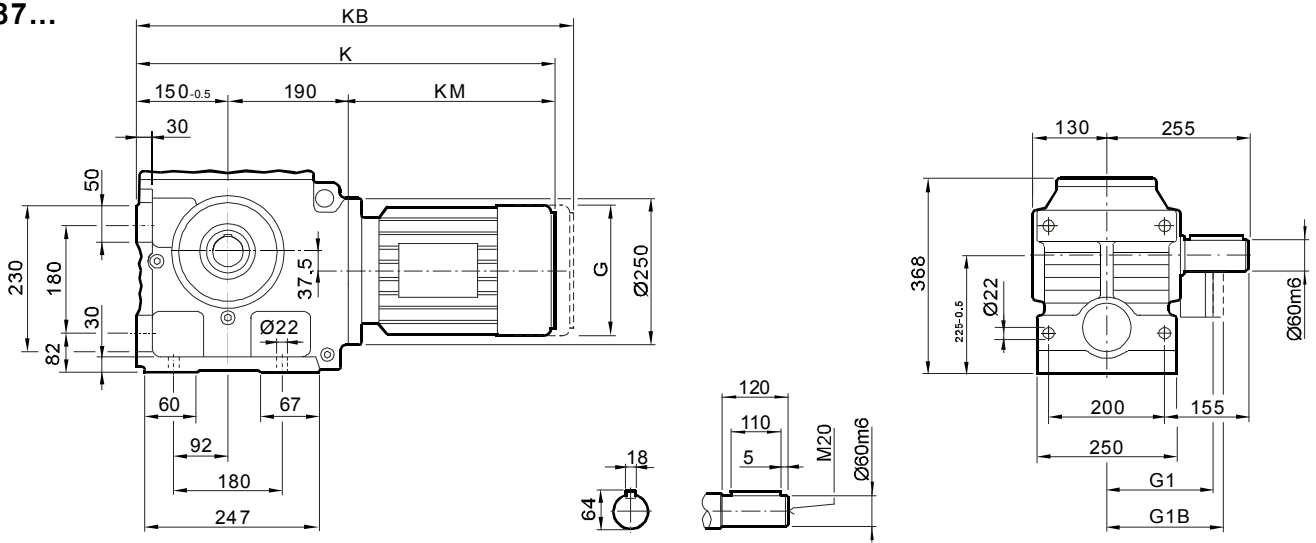

尺寸 Dimensions	电机规格 Motor frame										
	80	90	100M	100L	112M	132S	132M	160M	160L		
<b>G</b>	145	197	197	197	221	221	275	275	331		
<b>G1</b>	122	154	166	166	179	179	230	230	258		
<b>G1B</b>	127	161	166	166	182	182	230	230	258		
<b>K</b>	578	597	647	677	680	725	747	807	854		
<b>KB</b>	642	682	732	762	760	805	859	919	1010		
<b>KM</b>	238	257	307	337	340	385	407	467	514		

尺寸说明

以上尺寸为直联普通电机和制动电机尺寸；  
G1B,KB为制动电机尺寸,其余为普通电机尺寸；  
防爆电机, 辊道电机, 船用电机等须加过渡法兰, 见431页。

ATTENTION

Dimensions of general and brake motor shown in upon table, the others like explosion, roller, or marine motor coupled by adaptor, the dimensions on page 431.



安装尺寸

Mounting Dimensions

YSF87...

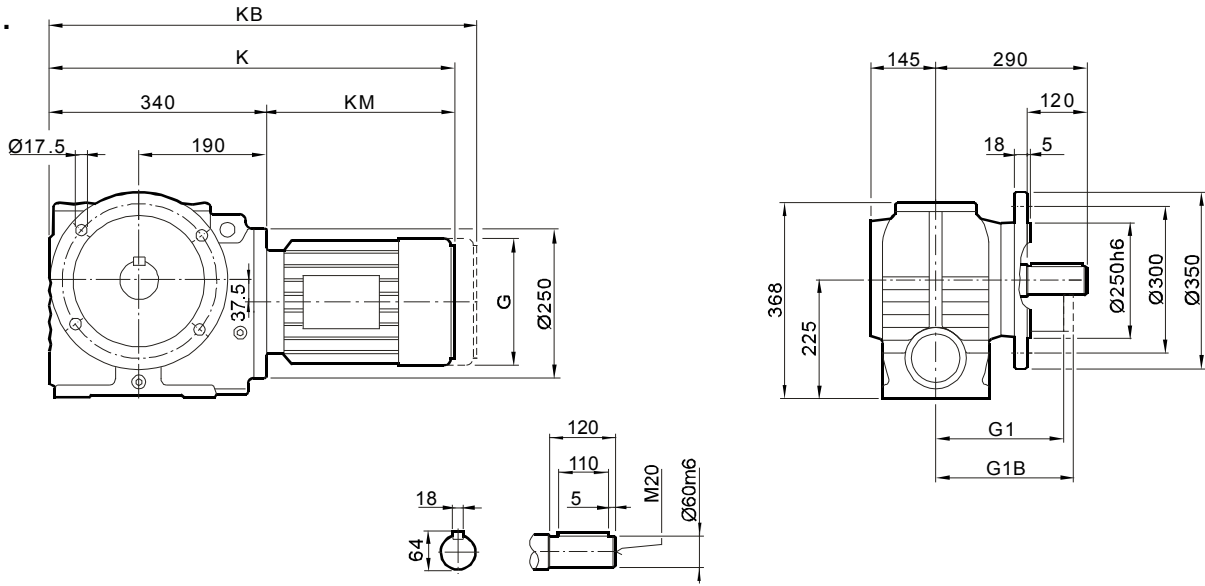

YSAF87...

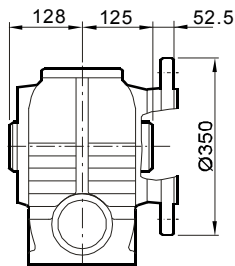

YSHF87...

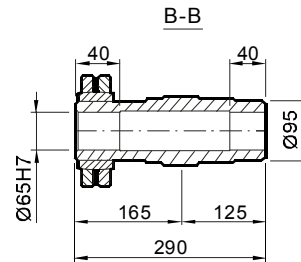
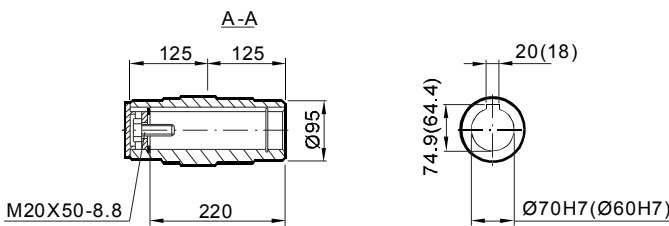
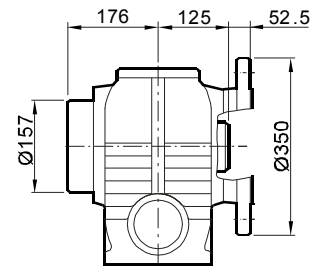

尺寸 Dimensions	电机规格 Motor frame									
	80	90	100M	100L	112M	132S	132M	160M	160L	
G	145	197	197	197	221	221	275	275	331	
G1	122	154	166	166	179	179	230	230	258	
G1B	127	161	166	166	182	182	230	230	258	
K	578	597	647	677	680	725	747	807	854	
KB	642	682	732	762	760	805	859	919	1010	
KM	238	257	307	337	340	385	407	467	514	

尺寸说明

以上尺寸为直联普通电机和制动电机尺寸；  
G1B,KB为制动电机尺寸,其余为普通电机尺寸；  
防爆电机，辊道电机，船用电机等须加过渡法兰，见431页。

ATTENTION

Dimensions of general and brake motor shown in upon table, the others like explosion, roller, or marine motor coupled by adaptor, the dimensions on page 431.



安装尺寸

Mounting Dimensions

YSA87...

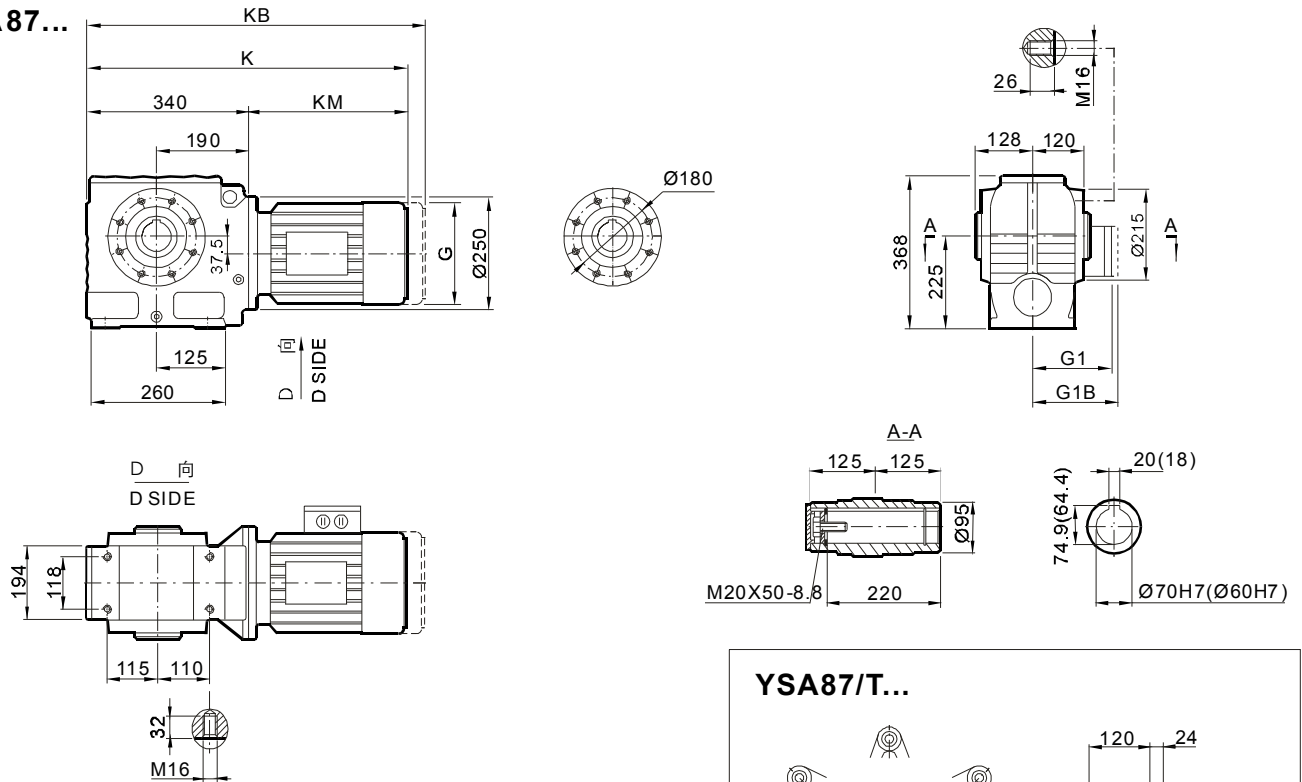

YSH87...

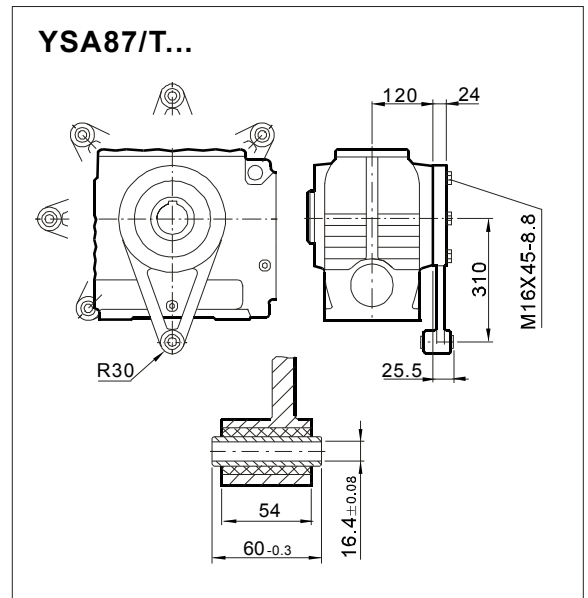
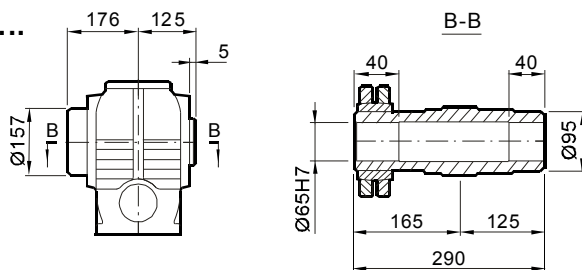

尺寸 Dimensions	电机规格 Motor frame									
	80	90	100M	100L	112M	132S	132M	160M	160L	
G	145	197	197	197	221	221	275	275	331	
G1	122	154	166	166	179	179	230	230	258	
G1B	127	161	166	166	182	182	230	230	258	
K	578	597	647	677	680	725	747	807	854	
KB	642	682	732	762	760	805	859	919	1010	
KM	238	257	307	337	340	385	407	467	514	

尺寸说明

以上尺寸为直联普通电机和制动电机尺寸；  
G1B,KB为制动电机尺寸,其余为普通电机尺寸；  
防爆电机, 辊道电机, 船用电机等须加过渡法兰, 见431页。

ATTENTION

Dimensions of general and brake motor shown in upon table, the others like explosion, roller, or marine motor coupled by adaptor, the dimensions on page 431.



安装尺寸

Mounting Dimensions

YSAZ87...

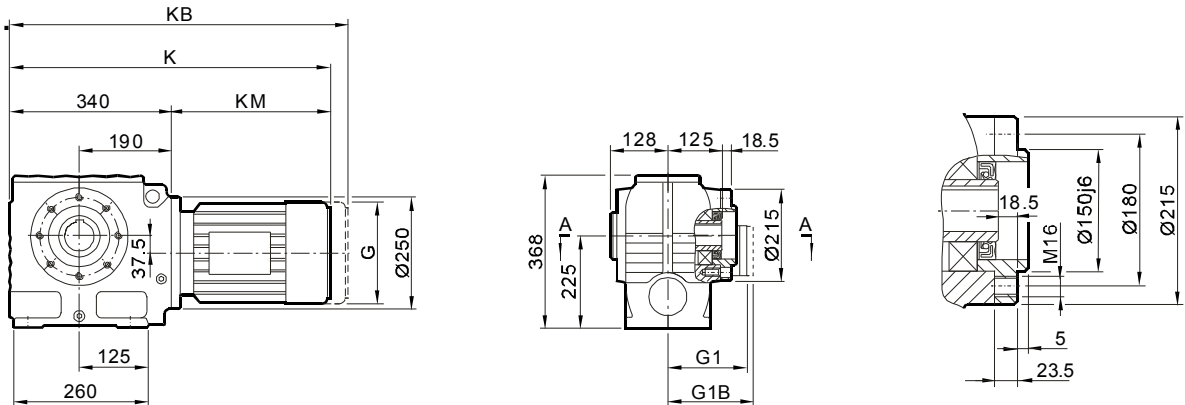

YSHZ87...

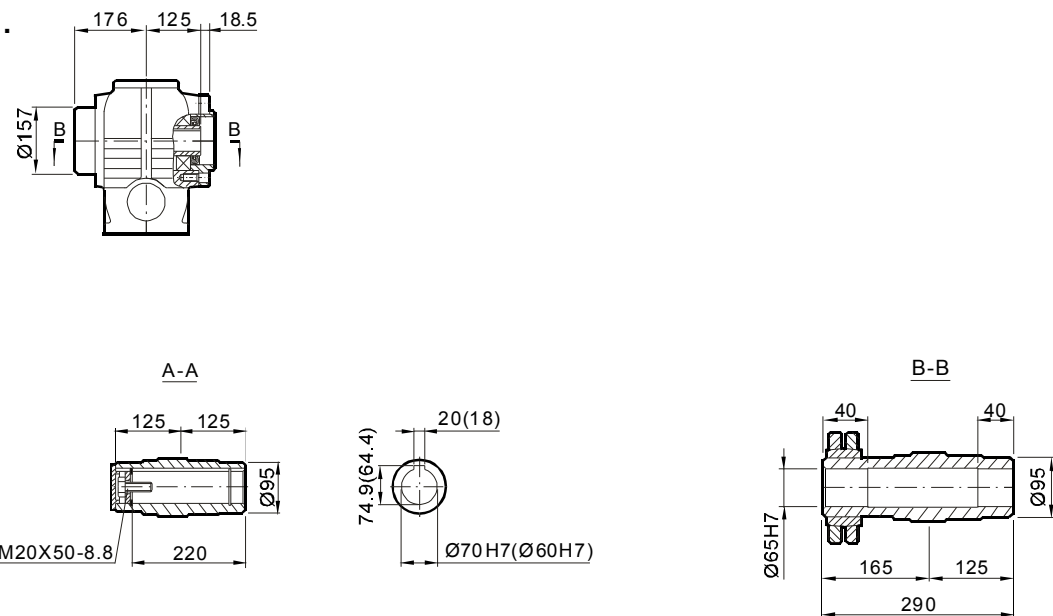

尺寸 Dimensions	电机规格 Motor frame									
	80	90	100M	100L	112M	132S	132M	160M	160L	
G	145	197	197	197	221	221	275	275	331	
G1	122	154	166	166	179	179	230	230	258	
G1B	127	161	166	166	182	182	230	230	258	
K	578	597	647	677	680	725	747	807	854	
KB	642	682	732	762	760	805	859	919	1010	
KM	238	257	307	337	340	385	407	467	514	

尺寸说明

以上尺寸为直联普通电机和制动电机尺寸；  
G1B,KB为制动电机尺寸,其余为普通电机尺寸；  
防爆电机，辊道电机，船用电机等须加过渡法兰，见431页。

ATTENTION

Dimensions of general and brake motor shown in upon table,  
the others like explosion, roller, or marine motor coupled by  
adaptor, the dimensions on page 431.



安装尺寸

Mounting Dimensions

YS97...

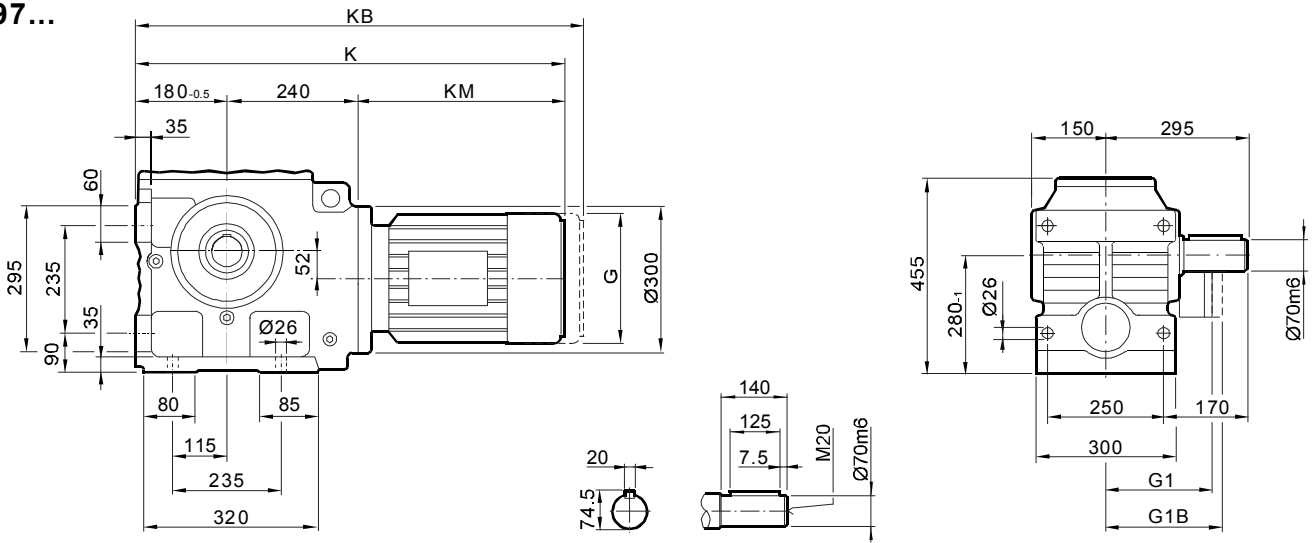

尺寸 Dimensions	电机规格 Motor frame										
	80	90	100M	100L	112M	132S	132M	160M	160L	180	
<b>G</b>	145	197	197	197	221	221	275	275	331	331	
<b>G1</b>	122	154	166	166	179	179	230	230	258	258	
<b>G1B</b>	127	161	166	166	182	182	230	230	258	258	
<b>K</b>	651	671	721	751	755	800	822	882	929	1001	
<b>KB</b>	715	756	806	836	835	880	934	994	1085	1157	
<b>KM</b>	238	251	301	331	335	380	402	462	509	581	

尺寸说明

以上尺寸为直联普通电机和制动电机尺寸；  
G1B,KB为制动电机尺寸,其余为普通电机尺寸；  
防爆电机, 辊道电机, 船用电机等须加过渡法兰, 见431页。

ATTENTION

Dimensions of general and brake motor shown in upon table, the others like explosion, roller, or marine motor coupled by adaptor, the dimensions on page 431.



安装尺寸

Mounting Dimensions

YSF97...

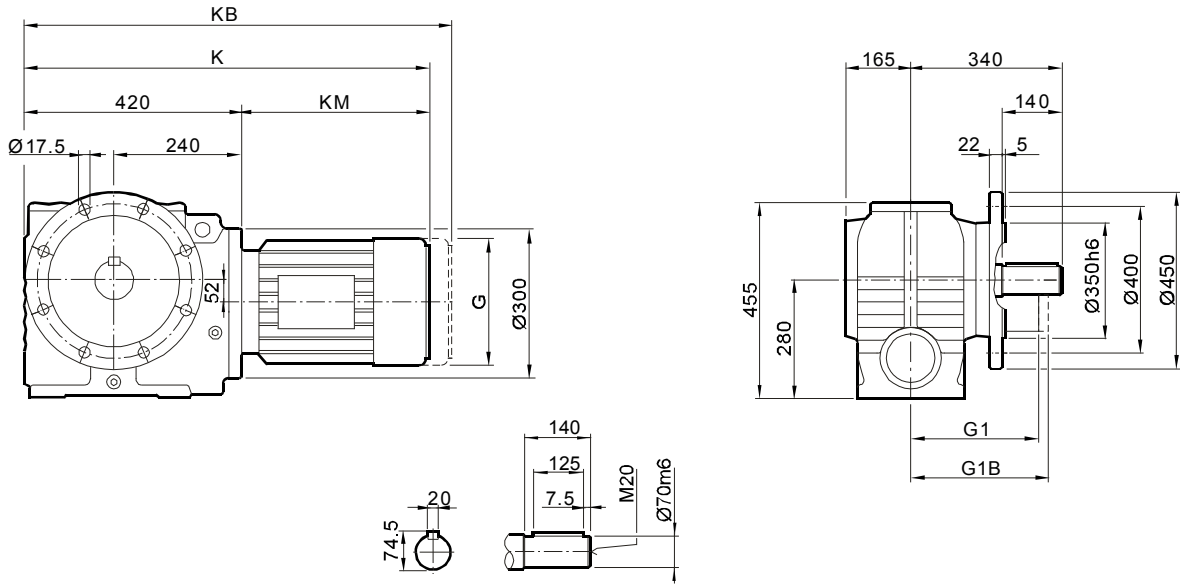

YSAF97...

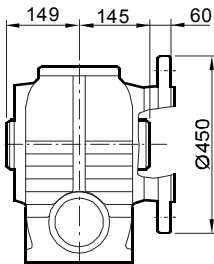

YSHF97...

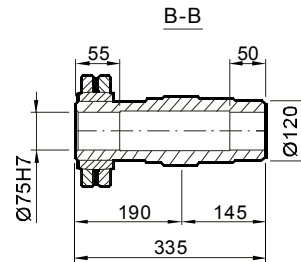
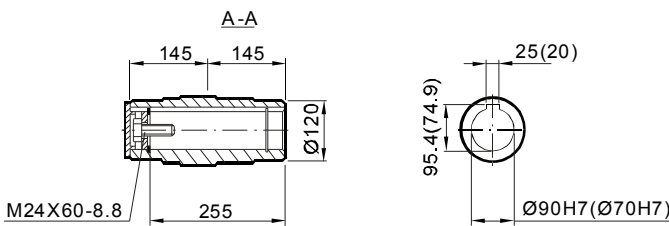
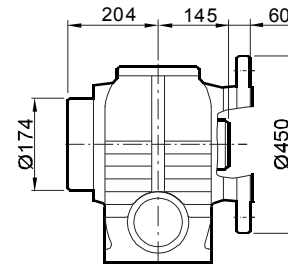

尺寸 Dimensions	电机规格 Motor frame									
	80	90	100M	100L	112M	132S	132M	160M	160L	180
<b>G</b>	145	197	197	197	221	221	275	275	331	331
<b>G1</b>	122	154	166	166	179	179	230	230	258	258
<b>G1B</b>	127	161	166	166	182	182	230	230	258	258
<b>K</b>	651	671	721	751	755	800	822	882	929	1001
<b>KB</b>	715	756	806	836	835	880	934	994	1085	1157
<b>KM</b>	238	251	301	331	335	380	402	462	509	581

尺寸说明

以上尺寸为直联普通电机和制动电机尺寸；  
G1B,KB为制动电机尺寸,其余为普通电机尺寸；  
防爆电机，辊道电机，船用电机等须加过渡法兰，见431页。

ATTENTION

Dimensions of general and brake motor shown in upon table, the others like explosion, roller, or marine motor coupled by adaptor, the dimensions on page 431.



安装尺寸

Mounting Dimensions

YSA97...

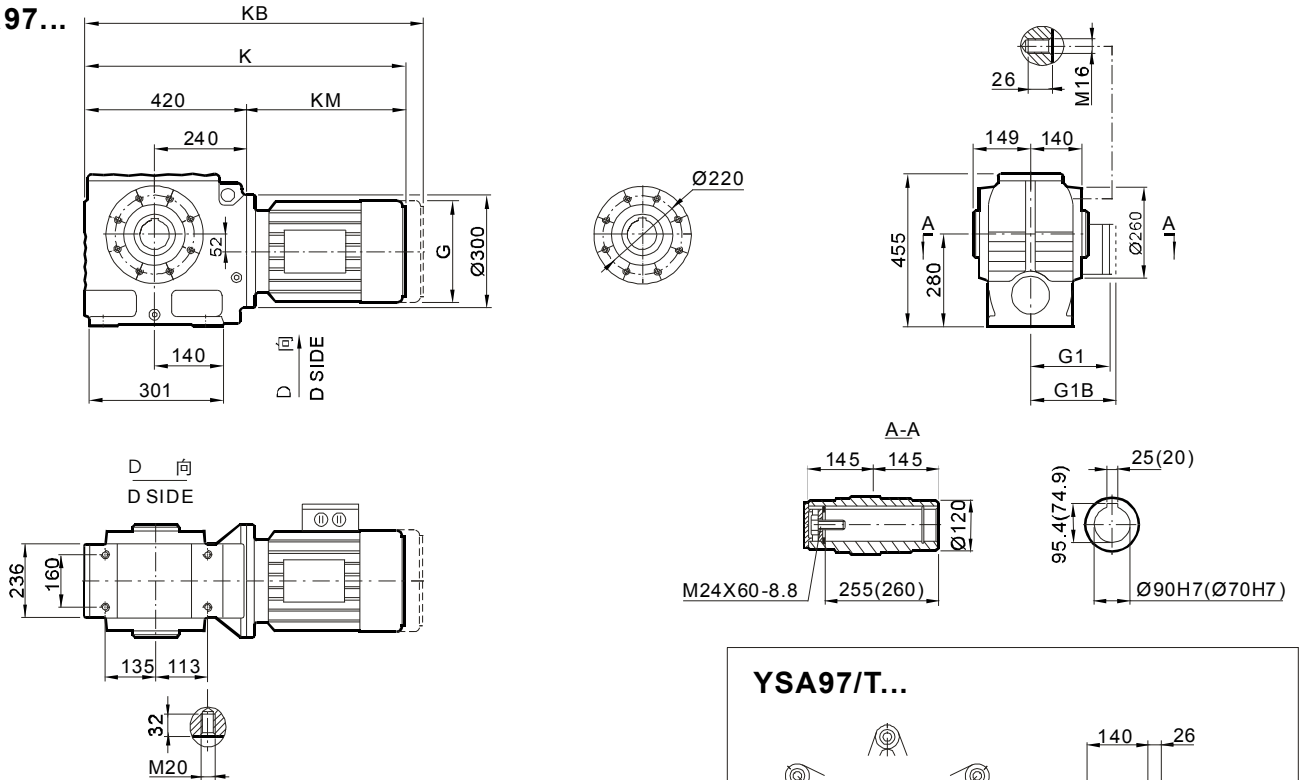

YSH97...

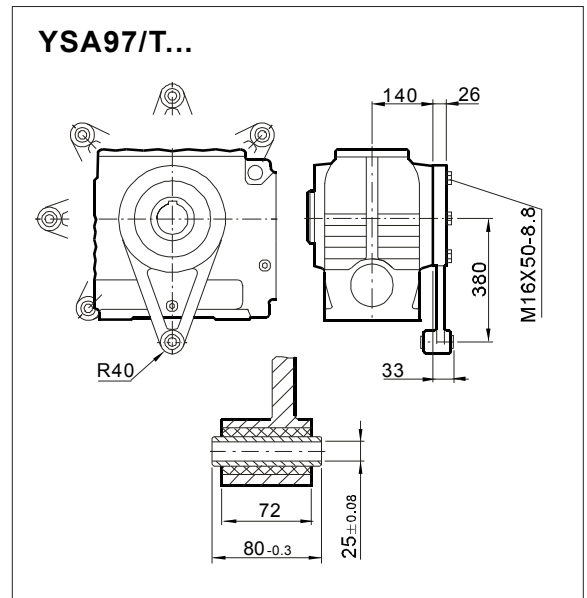
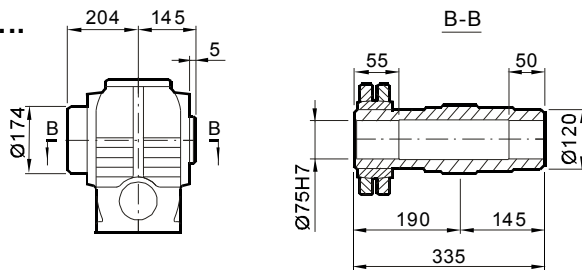

尺寸 Dimensions	电机规格 Motor frame									
	80	90	100M	100L	112M	132S	132M	160M	160L	180
G	145	197	197	197	221	221	275	275	331	331
G1	122	154	166	166	179	179	230	230	258	258
G1B	127	161	166	166	182	182	230	230	258	258
K	651	671	721	751	755	800	822	882	929	1001
KB	715	756	806	836	835	880	934	994	1085	1157
KM	238	251	301	331	335	380	402	462	509	581

尺寸说明

以上尺寸为直联普通电机和制动电机尺寸；  
G1B,KB为制动电机尺寸,其余为普通电机尺寸；  
防爆电机, 辊道电机, 船用电机等须加过渡法兰, 见431页。

ATTENTION

Dimensions of general and brake motor shown in upon table, the others like explosion, roller, or marine motor coupled by adaptor, the dimensions on page 431.



安装尺寸

Mounting Dimensions

**YSAZ97...**

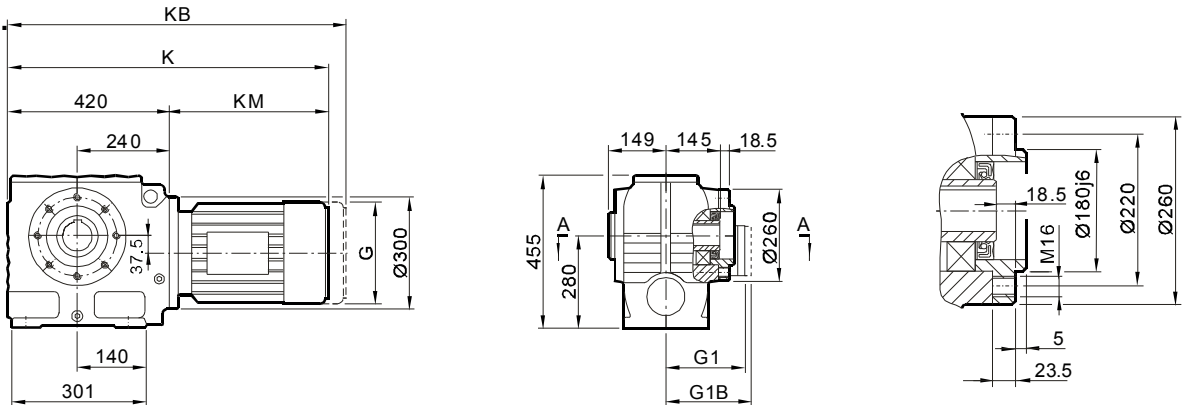

**YSHZ97...**

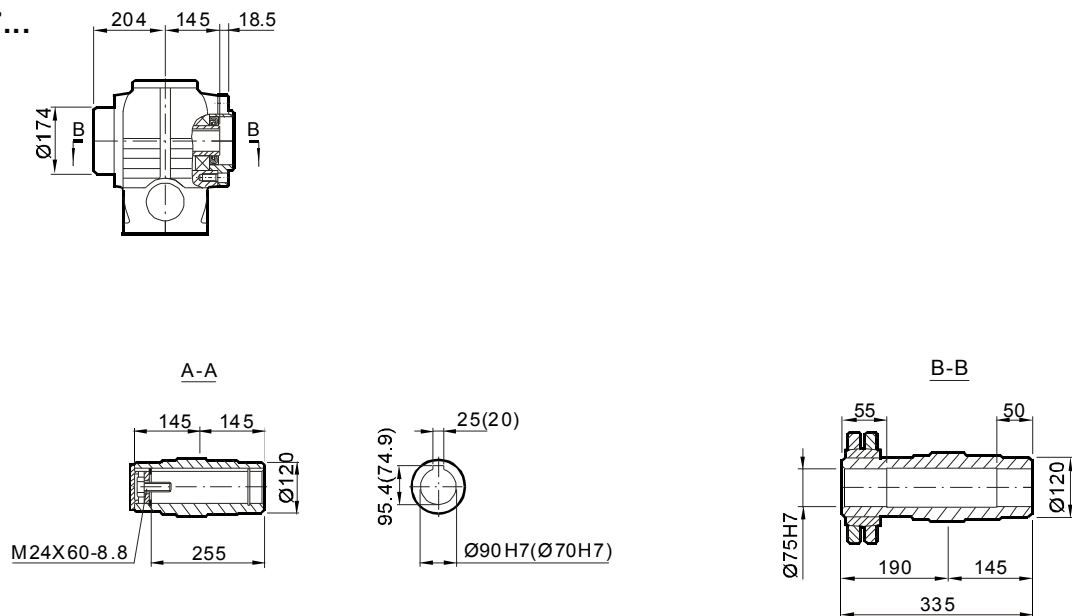

尺寸 Dimensions	电机规格 Motor frame									
	80	90	100M	100L	112M	132S	132M	160M	160L	180
<b>G</b>	145	197	197	197	221	221	275	275	331	331
<b>G1</b>	122	154	166	166	179	179	230	230	258	258
<b>G1B</b>	127	161	166	166	182	182	230	230	258	258
<b>K</b>	651	671	721	751	755	800	822	882	929	1001
<b>KB</b>	715	756	806	836	835	880	934	994	1085	1157
<b>KM</b>	238	251	301	331	335	380	402	462	509	581

尺寸说明

以上尺寸为直联普通电机和制动电机尺寸；  
G1B,KB为制动电机尺寸,其余为普通电机尺寸；  
防爆电机, 辊道电机, 船用电机等须加过渡法兰, 见431页。

**ATTENTION**

Dimensions of general and brake motor shown in upon table, the others like explosion, roller, or marine motor coupled by adaptor, the dimensions on page 431.



安装尺寸

Mounting Dimensions

组合型尺寸

Combinations

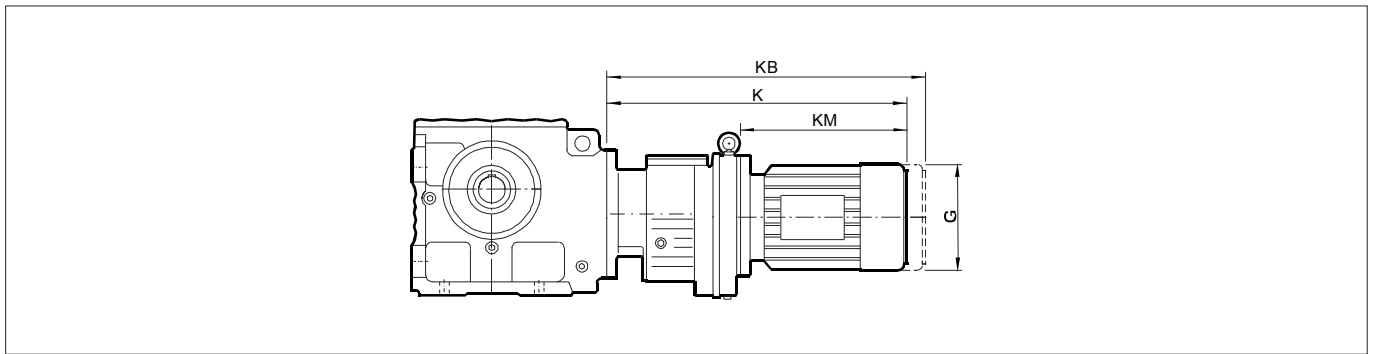

减速机规格 Gear unit size	电机规格 Motor frame	G	K	KB	KM
<b>YS..37YR17</b>	<b>63..</b>	132	338	395	163
	<b>71..</b>	145	339	403	164
	<b>80..</b>	145	389	453	214
<b>YS..47YR37</b> <b>YS..57YR37</b>	<b>63..</b>	132	370	427	205
	<b>71..</b>	145	371	435	206
	<b>80..</b>	145	421	485	256
<b>YS..67YR37</b>	<b>63..</b>	132	362	419	205
	<b>71..</b>	145	363	427	206
	<b>80..</b>	145	413	477	256
<b>YS..77YR37</b>	<b>63..</b>	132	415	472	199
	<b>71..</b>	145	415	479	199
	<b>80..</b>	145	465	529	249
	<b>90..</b>	197	485	570	269
<b>YS..87YR57</b>	<b>63..</b>	132	410	467	199
	<b>71..</b>	145	410	474	199
	<b>Y80..</b>	145	460	524	249
	<b>90..</b>	197	480	565	269
	<b>100L1</b>	197	530	615	319
	<b>100L2</b>	197	560	645	349
<b>YS..97YR57</b>	<b>63..</b>	132	410	467	199
	<b>71..</b>	145	410	474	199
	<b>80..</b>	145	460	524	249
	<b>90..</b>	197	480	565	269
	<b>100L1</b>	197	530	615	319
	<b>100L2</b>	197	560	645	349
	<b>112M</b>	221	565	645	354



安装尺寸

Mounting Dimensions

联结法兰尺寸

Adapter dimensions

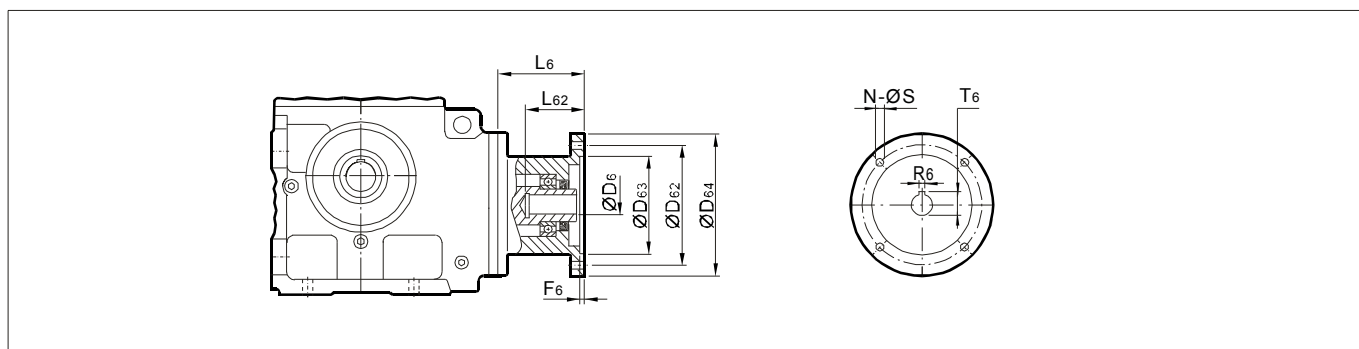

减速机型号 Gear unit size	法兰规格 Motor frame	D <sub>6</sub>	T <sub>6</sub>	R <sub>6</sub>	F <sub>6</sub>	L <sub>6</sub>	L <sub>62</sub>	D <sub>64</sub>	D <sub>62</sub>	D <sub>63</sub>	N	S
YS..37 YS..47 YS..57	63B5	11	12.8	4	3.5	83	26	140	115	95	4	10
	71B5	14	16.3	5	3.5	83	33	160	130	110	4	10
	80B5	19	21.8	6	4.5	103	43	200	165	130	4	12
	90B5	24	27.3	8	4.5	103	53	200	165	130	4	12
YS..67	63B5	11	12.8	4	3.5	83	26	140	115	95	4	10
	71B5	14	16.3	5	3.5	83	33	160	130	110	4	10
	80B5	19	21.8	6	4.5	103	43	200	165	130	4	12
	90B5	24	27.3	8	4.5	103	53	200	165	130	4	12
	100B5	28	31.3	8	5	110	63	250	215	180	4	15
	112B5	28	31.3	8	5	110	63	250	215	180	4	15
YS..77	63B5	11	12.8	4	3.5	83	26	140	115	95	4	10
	71B5	14	16.3	5	3.5	83	33	160	130	110	4	10
	80B5	19	21.8	6	4.5	103	43	200	165	130	4	12
	90B5	24	27.3	8	4.5	103	53	200	165	130	4	12
	100B5	28	31.3	8	5	110	63	250	215	180	4	15
	112B5	28	31.3	8	5	110	63	250	215	180	4	15
YS..87	63B5	11	12.8	4	3.5	83	26	140	115	95	4	10
	71B5	14	16.3	5	3.5	83	33	160	130	110	4	10
	80B5	19	21.8	6	4.5	103	43	200	165	130	4	12
	90B5	24	27.3	8	4.5	103	53	200	165	130	4	12
	100B5	28	31.3	8	5	110	63	250	215	180	4	15
	112B5	28	31.3	8	5	110	63	250	215	180	4	15
YS..97	100B5	28	31.3	8	5	110	63	250	215	180	4	15
	112B5	28	31.3	8	5	110	63	250	215	180	4	15
	132B5	38	41.3	10	5	133	85	300	265	230	4	15
	160B5	42	45.3	12	6	171	115	350	300	250	4	19
	180B5	28	31.3	8	5	110	63	250	215	180	4	15

注意!

- 1 选用底脚安装减速机时, 尺寸ØD64可能会超过底脚安装面, 请注意校核。
- 2 适配电机参照IEC B5法兰规格,其它未注尺寸请参考相关机型号。

Attention!

- 1 Dimension ØD64 may protrude past foot mounting surface if selecting foot-mounted type.
- 2 the motor flange follow IEC B5 type, dimensions is not indicated, please refer to correlative gear unit size



安装尺寸

Mounting Dimensions

输入轴尺寸

Input Shaft Dimensions

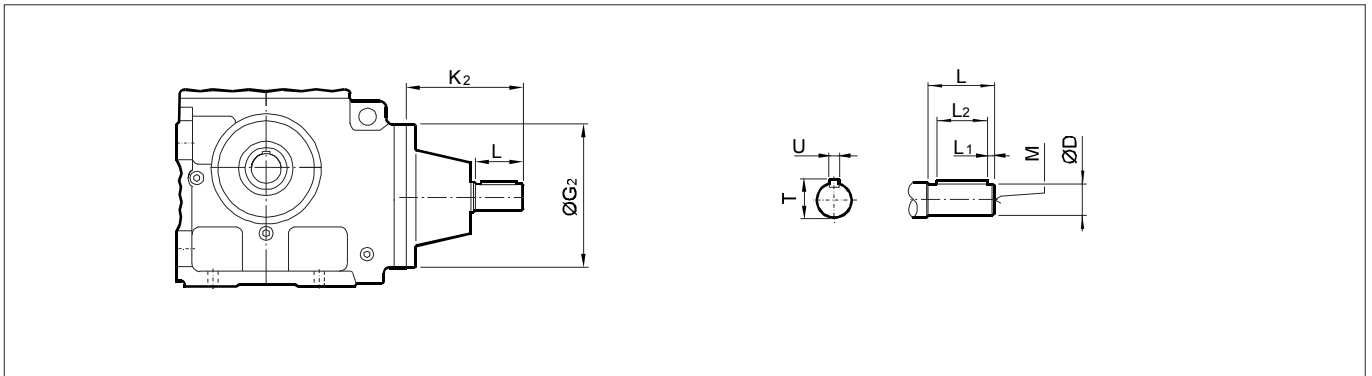

减速机型号 Gear unit size	D	G <sub>2</sub>	K <sub>2</sub>	L	M	L <sub>1</sub>	L <sub>2</sub>	T	U
<b>YS..37S</b>	16k6	120	115	40	M5	4	32	18	5
<b>YS..47S</b>	16k6	120	115	40	M6	4	32	18	6
<b>YS..57S</b>	16k6	120	115	40	M6	4	32	18	6
<b>YS..67S</b>	19k6	160	120	40	M6	4	32	21.5	6
<b>YS..77S</b>	24k6	200	140	50	M8	5	40	27	8
<b>YS..87S</b>	28k6	250	180	60	M10	5	50	31	8
<b>YS..97S</b>	38k6	300	220	80	M12	5	70	41	10

注意！

其它未注尺寸请参考相关机型号。

**Attention!**

Dimensions is not indicated, please refer to correlative gear unit size



添加企业微信



微信选型小程序



注：有关本产品的内容，随着技术进步等，将会有变更，不另行通知，望谅解！