



目录	页面	Contents	Page
----	----	----------	------

YR系列圆柱斜齿轮减速机

产品外形	2-2
型号标记	3-3
电机配置说明	3-4
安装位置	5-8
技术参数	9-95
安装尺寸	96-137
YRM型减速机	138-142

YR Series Helical Gear Motor

Products Figure	2-2
Designation	3-3
Configuration of Electric Motor	3-4
Mounting Position	5-8
Technical Data	9-95
Mounting Dimensions	96-137
YRM Gear Unit	138-142

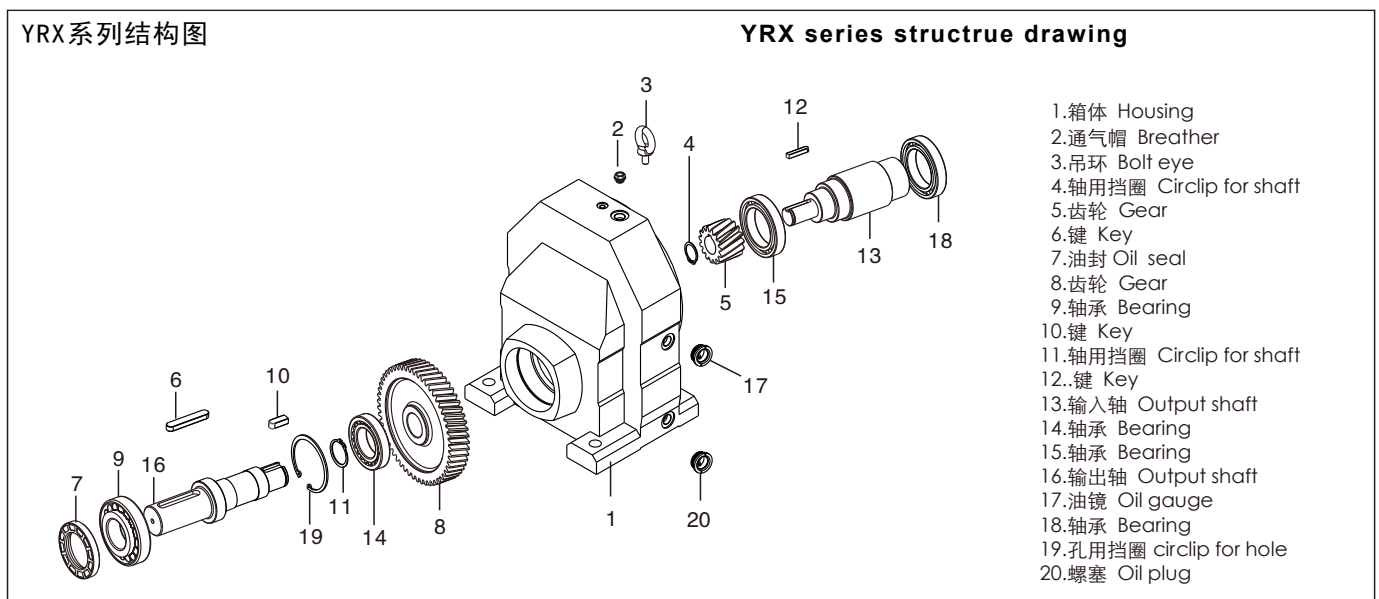
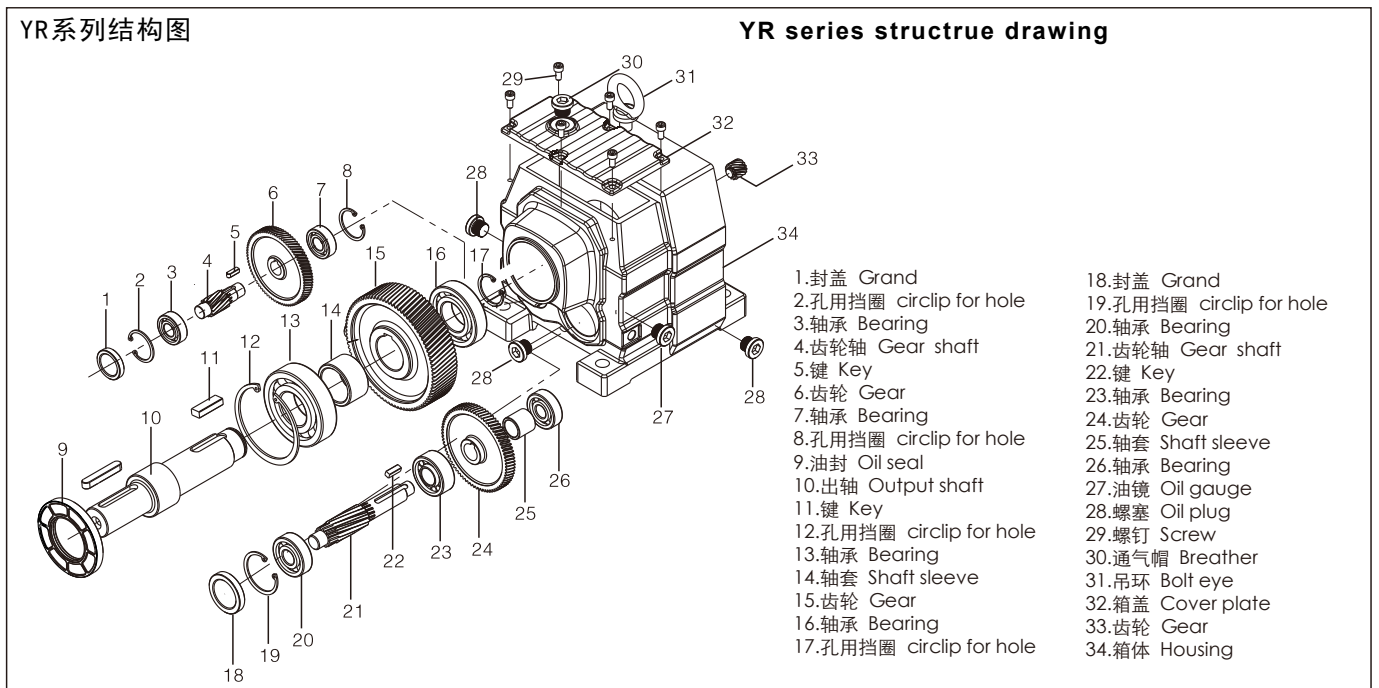



产品外形

Products Figure

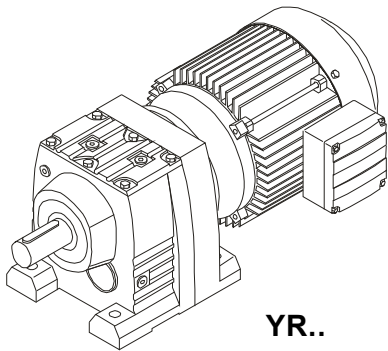

YR..

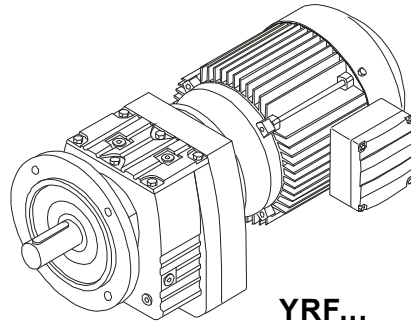

YRF...

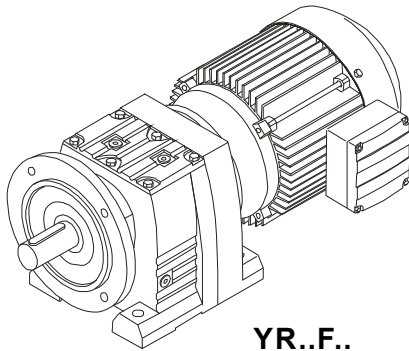

YR..F..

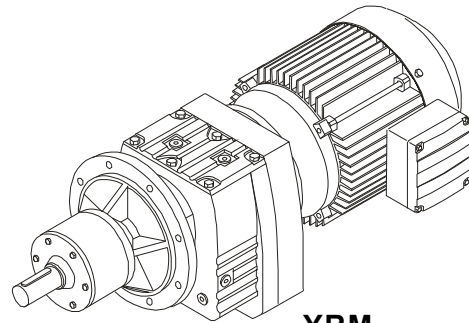

YRM..

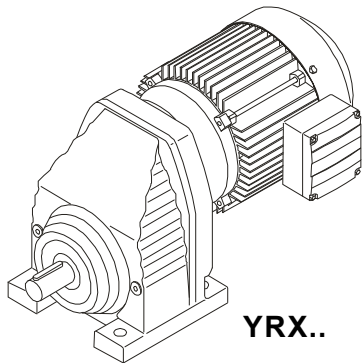

YRX..

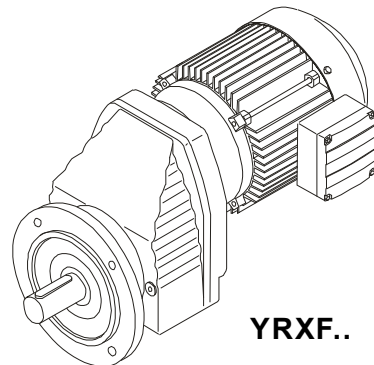

YRXF..

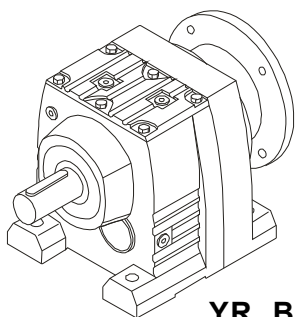

YR..B5

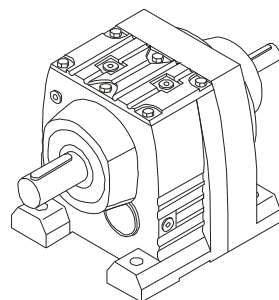

YR..S..



型号标记

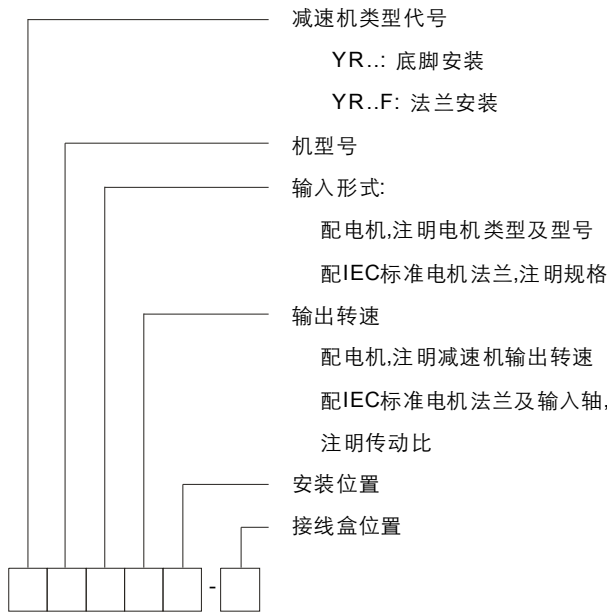

标记示例

- A YR47Y71M2-4NA12M1-0
底脚安装,机型号47,电机规格71M2-4,输出转速12rpm,安装位置M1,电机接线盒位置0°
- B YR67YB100L1-4NA38M2-180 (dIIBT4 IP54/F)
底脚安装,机型号67,防爆电机YB100L1-4,防爆等级dII BT4,防护等级IP54,绝缘等级F,输出转速38rpm,安装位置M2,电机接线盒位置180°
- C YRF167-160B5-159-M2 (Ø50)
法兰安装,机型号167,电机法兰160B5,减速比159,安装位置M2,法兰外径Ø550.

电机配置说明

Y系列普通三相异步电机

- 1 本系列减速机标准配置Y系列普通三相异步感应电机;
- 2 电机电压: 380V/50Hz;
- 3 电机防护等级IP54, 绝缘等级F, B级温升;
- 4 环境温度不超过 不低于-15℃; 40℃,
- 5 连续工作制S1;
- 6 海拔高度不超过1000m;
- 7 冷却方式为C0141 (风扇自冷);
- 8 100及以下规格为"Y"接法, 112M及以上规格为"△"接法;
- 9 优先选用4, 6, 8极电机, 2极电机不推荐使用;
- 10 电机技术参数见第433-438页

Designation

- gear unit type
YR...:foot-mounted
YR..F:flange-mounted
- gear unit size
- inputstructure:
connect with motor, indicate motor model
connect with IEC flange, indicate frame
- output speed
connect with motor, indicate output speed
connect with IEC flange or input shaft, indicate ratio
- mounting position
- terminal box position

Sign Example

- A YR47Y71M2-4NA12M1-0
foot-mounted,gear unit size 47,motor size 71M2-4,output speed 12rpm, mounting position M1,terminal box 0
- B YR67YB100L1-4NA38M2-180 (dII BT4 IP54/F)
foot-mounted,gear unit size 67,motor size YB100L1-4,output speed 38rpm, mounting position M2,terminal box 180
- C YRF167-160B5-159-M2 (Ø50)
flange-mounted,gear unit size 167,motor flange 160B5,transmission ratio 159, mounting position M2,output flange diameterØ 550.

Configuration of Electric Motor

Y series Three-phase Asynchronous Electric Motor

- 1 this series gear unit configure three-phase asynchronous electric motor;
- 2 voltage:380V/50Hz;
- 3 protection class:IP54,insulation class: F; temperature rising class: B;
- 4 ambient temperature:-15~40 ℃;
- 5 continue working duty:S1;
- 6 altitude less than 1000m;
- 7 self-cooling with fan:C0141;
- 8 within frame 100, follow connection Y, from frame 112, follow connection△;
- 9 first select 4,6,8 poles motor;
- 10 technical data on page 433-438.



电机配置说明

Configuration of Electric Motor

YEJ系列三相异步制动电机

- 1 三相异步制动电机为普通电机的基础上附加制动器;
- 2 电机电压: 380V/50Hz;
- 3 制动器电压: 规格71~100: DC99V
规格112~200: DC170V
- 4 配置单相AC220/50Hz整流器;
- 5 电机防护等级IP44, 绝缘等级F, B级温升;
- 6 环境温度不超过40℃, 不低于-15℃;
- 7 连续工作制S1;
- 8 海拔高度不超过1000m;
- 9 冷却方式为C0141 (风扇自冷);
- 10 100及以下规格为"Y"接法, 112M及以上规格为"Δ"接法;
- 11 优先选用4, 6, 8极电机, 2极电机不推荐使用。
- 12 电机技术参数见第433-438页

YEJ series Three-phase Asynchronous Brake Motor

- 1 base on Y series motor, add a brake.
- 2 voltage:380V/50Hz;
- 3 brake voltage: frame:71~100 DC99V
frame:112~200 DC170V;
- 4 with single phase AC220V/50Hz rectifier;
- 5 protection class:IP54,insulation class: F, temperature rising class: B;
- 6 ambient temperature:-15~40C ;
- 7 continue working duty:S1;
- 8 altitude less than 1000m;
- 9 self-cooling with fan:C0141;
- 10 upon to frame 100, follow connection Y, from frame 112, follow connection Δ ;
- 11 first select 4,6,8 poles motor;
- 12 technical data on page 433-438.

YVF系列三相异步变频电机

- 1 电机电压: 380V;
- 2 基准频率: 50Hz;
- 3 允许调频5~50Hz, 恒转矩调速;
- 4 电机防护等级IP54, 绝缘等级F, B级温升;
- 5 环境温度不超过40℃, 不低于-15℃;
- 6 连续工作制S1;
- 7 海拔高度不超过1000m;
- 8 冷却方式为C416 (独立风扇);
- 9 接线方式按适配变频器要求;
- 10 优先选用4极电机。

YVF series Three-phase Variable-frequency Motor

- 1 voltage:380V;
- 2 rated frequency 50Hz;
- 3 available frequency:5~50Hz;
- 4 protection class:IP54,insulation class: F, temperature rising class:B;
- 5 ambient temperature:-15~40C ;
- 6 continue working duty:S1;
- 7 altitude less than 1000m;
- 8 cooling with independence fan:C416;
- 9 connection perform the requirement of inverter;
- 10 first select 4 poles motor;

特殊电机

- 1 选用包括防爆电机, 辊道电机, 船用电机, 多速电机等特殊电机, 本公司提供IEC标准电机法兰接口, 接口尺寸见135-136页;
- 2 异频率, 异电压电机, 请联系本公司技术部;
- 3 使用环境温度不在-15~40℃范围内, 请联系本公司技术部;
- 4 更高的绝缘等级及防护等级, 请联系本公司技术部。

Customized Motor

- 1 others like explosion proof, roller motor, marine motor or multi-speed motor coupled by adaptor, the dimensions on page 135-136.
- 2 need different frequency and voltage, please contact us.
- 3 ambient temperature is out of -15~40C ,please contact us.
- 4 for higher insulation and protection class, please contact us.



安装位置

Mounting Position

减速机安装位置

Gear Unit Mounting Position

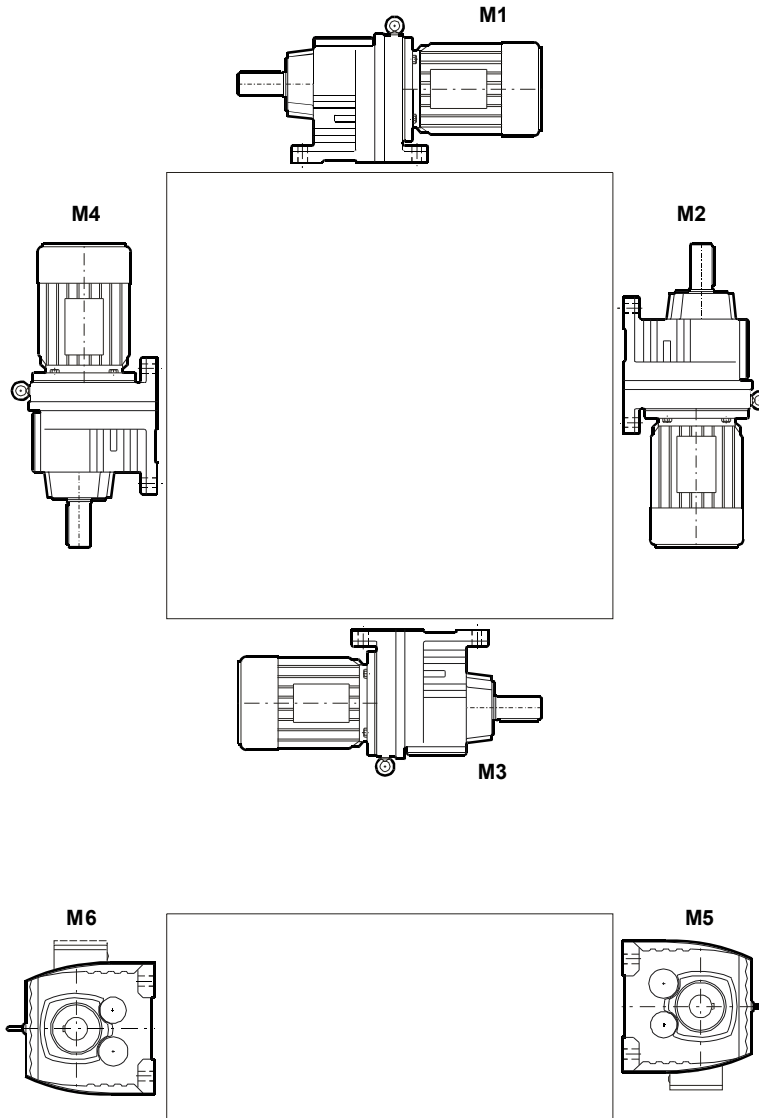

接线盒位置

Terminal Box Position

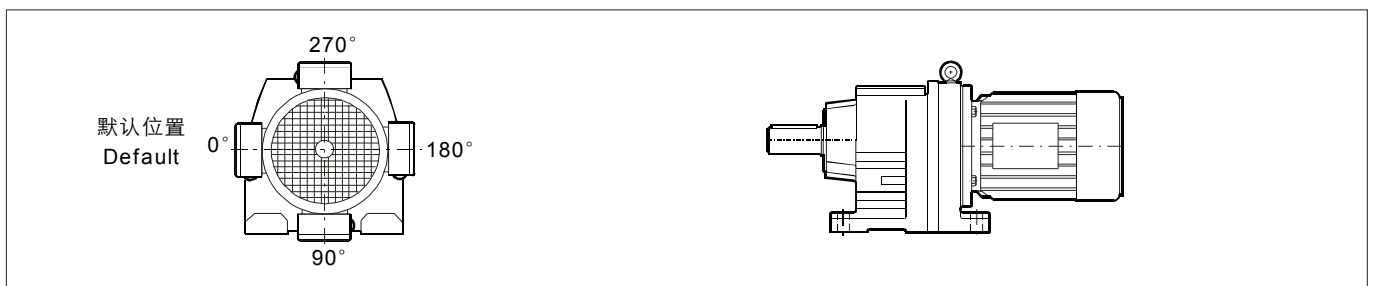



安装位置

Mounting Position

减速机安装位置

Gear Unit Mounting Position

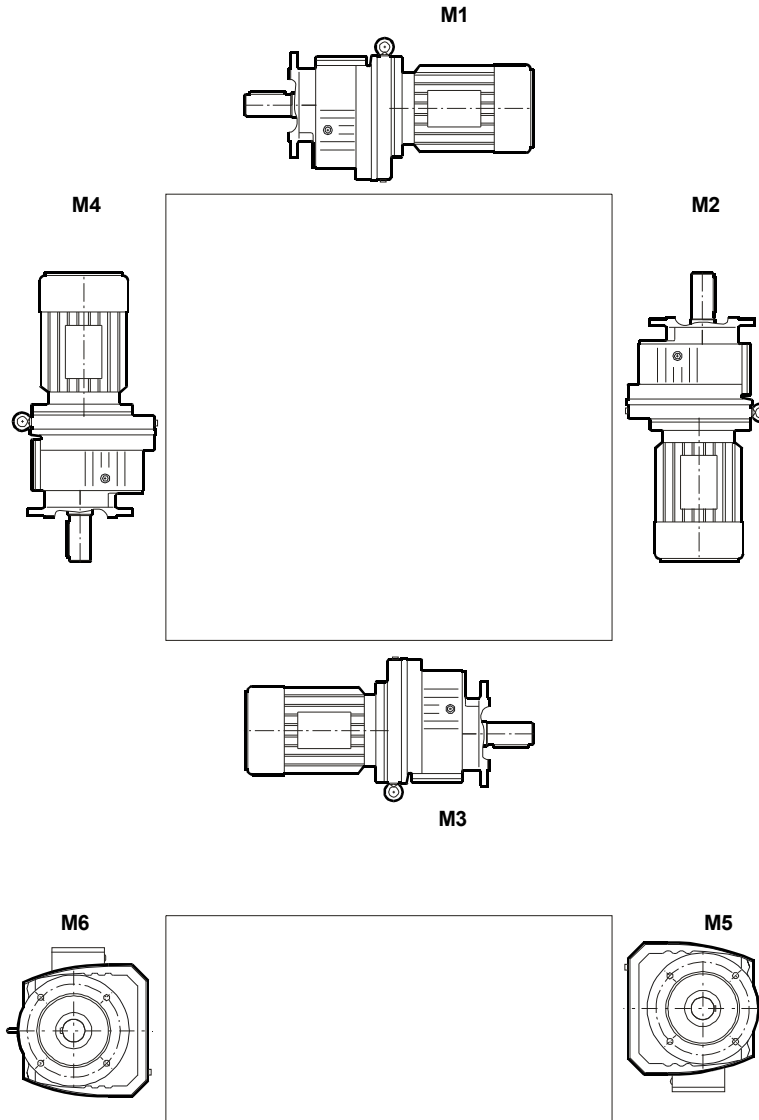

接线盒位置

Terminal box position

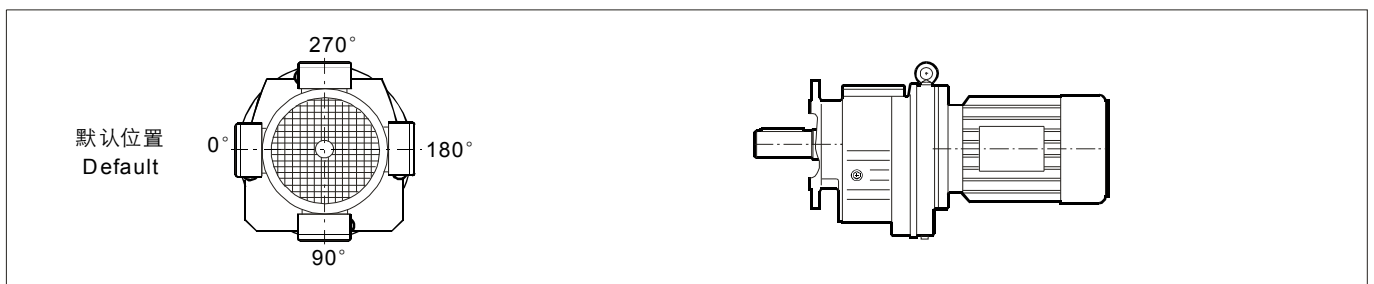



安装位置

Mounting Position

减速机安装位置

Gear Unit Mounting Position

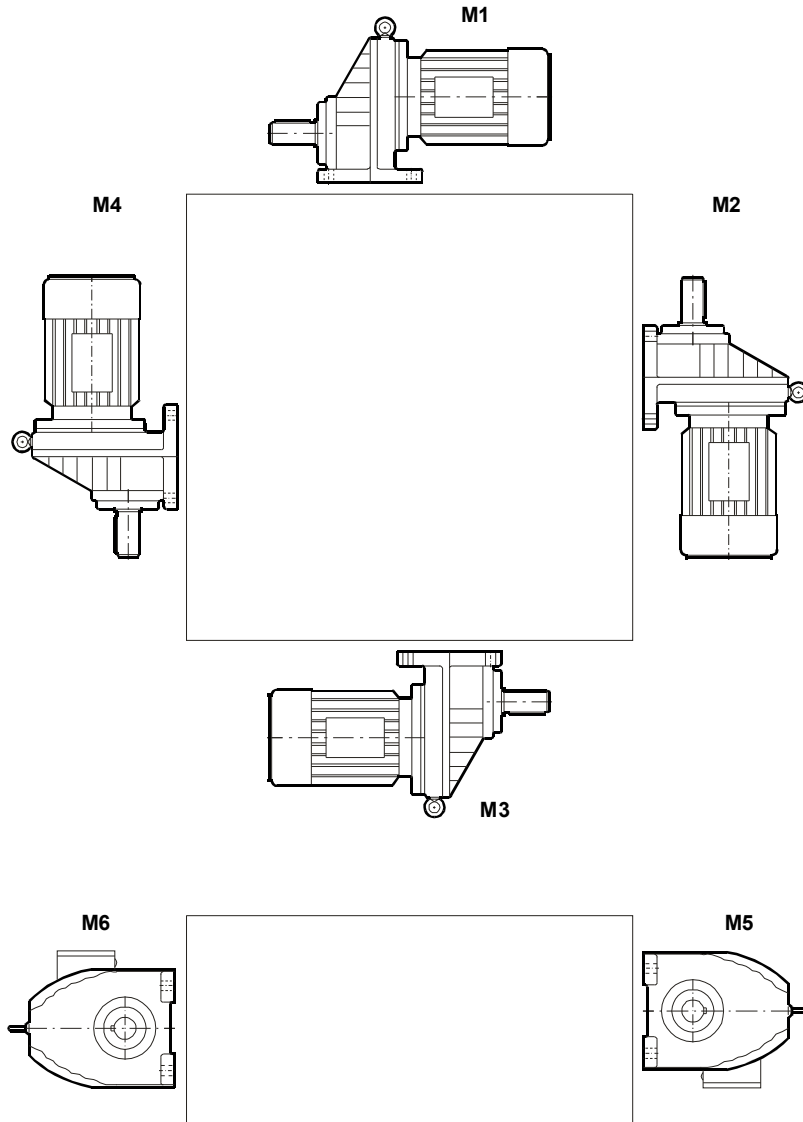

接线盒位置

Terminal box position

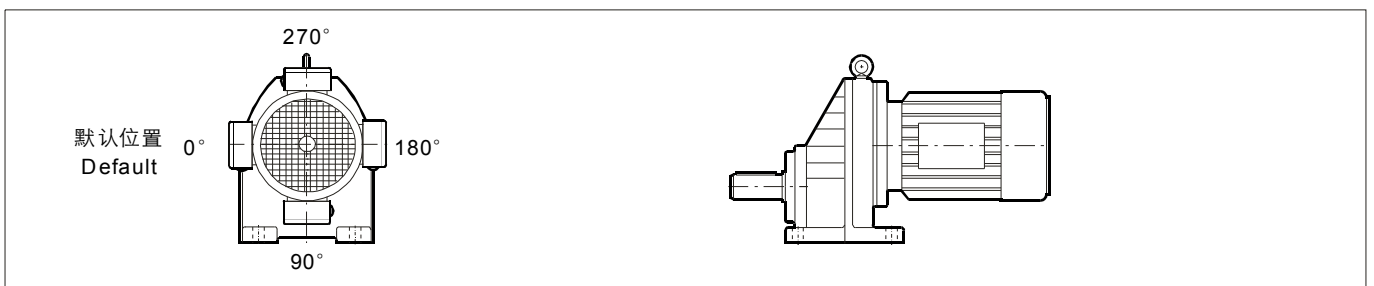



安装位置

Mounting Position

减速机安装位置

Gear Unit Mounting Position

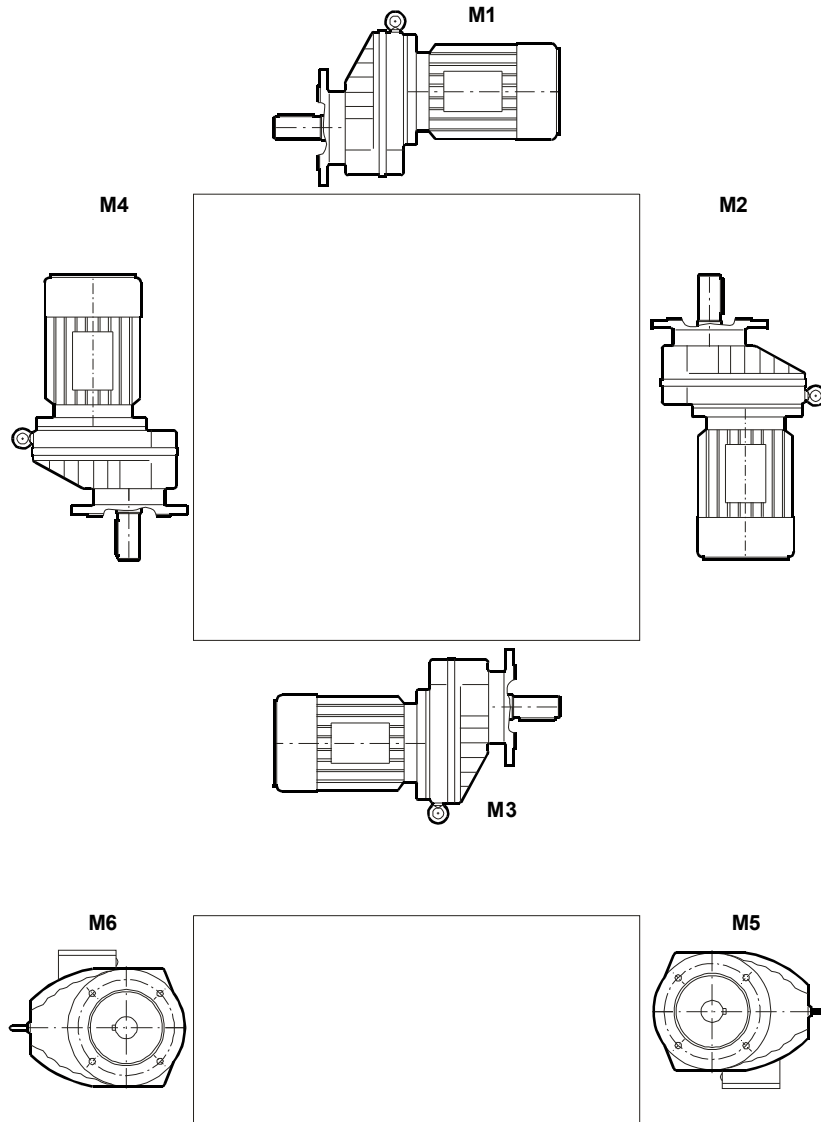

接线盒位置

Terminal box position

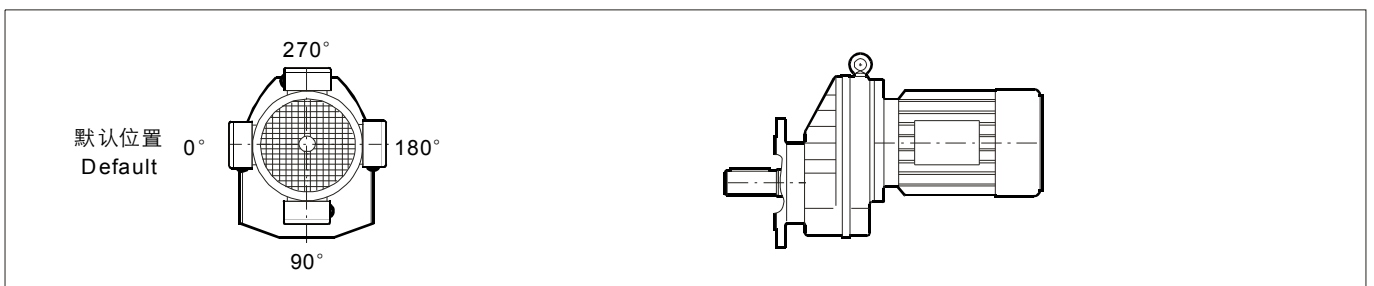



技术参数

Technical Data

符号意义

Key to Symbols

①
↓

$P_1 = 0.12 \text{ kW}$

NA rpm	M ₂ Nm	i	Fr _{2MAX} [N]	f _s	Type	Gear unit	Motor size	 Kg
0.06	13300	21342	62000	1.00				
0.08	11400	18210	65700	1.15				
0.09	9930	15923	67900	1.30				
0.10	8780	14075	69400	1.50				
0.11	7650	12344	70700	1.70				
0.12	6740	11143	71600	1.95	YR	147 YR77	63M1-4	420
0.14	6040	9743	72200	2.2	YRF	147 YR77	63M1-4	430
0.16	4830	8443	73100	2.7				
0.19	4180	7307	73400	3.1				
0.21	3690	6447	73700	3.5				
0.25	3190	5568	73900	4.1				
↑ ②	↑ ③	↑ ④	↑ ⑤	↑ ⑥	↑ ⑦	↑ ⑧	↑ ⑨	↑ ⑩

- 1 电机功率
- 2 输出转速
- 3 输出转矩
- 4 减速比
- 5 输出轴中最大点载荷
- 6 使用系数
- 7 减速机类型
- 8 减速机规格
- 9 电机型号
- 10 大概重量

- 1 motor power
- 2 output speed
- 3 output torque
- 4 transmission ratio
- 5 maximum load on middle output shaft
- 6 service factor
- 7 gear unit type
- 8 gear unit size
- 9 motor frame
- 10 approximate weight



技术参数

Technical Data

P ₁ = 0.12 kW								
NA rpm	M ₂ Nm	i	Fr ₂ MAX[N]	f _s	Type	Gear unit	Motor size	 Kg
0.06	13300	21342	62000	1.00				
0.08	11400	18210	65700	1.15				
0.09	9930	15923	67900	1.30				
0.10	8780	14075	69400	1.50				
0.11	7650	12344	70700	1.70				
0.12	6740	11143	71600	1.95	YR	147 YR77	63M1-4	420
0.14	6040	9743	72200	2.2	YRF	147 YR77	63M1-4	430
0.16	4830	8443	73100	2.7				
0.19	4180	7307	73400	3.1				
0.21	3690	6447	73700	3.5				
0.25	3190	5568	73900	4.1				
0.11	8060	12921	53300	1.00				
0.12	7260	11712	54900	1.10				
0.13	6390	10573	56400	1.25				
0.16	5030	8784	58400	1.60	YR	137 YR77	63M1-4	290
0.18	4090	7479	59400	1.95	YRF	137 YR77	63M1-4	310
0.21	4060	6559	59400	1.95				
0.24	3190	5834	60200	2.5				
0.27	3170	5116	60200	2.5				
0.18	4410	7583	28800	0.95				
0.20	3690	6743	32400	1.15				
0.23	3660	5914	32500	1.15				
0.27	2830	5168	35500	1.50	YR	107 YR77	63M1-4	200
0.31	2540	4435	36100	1.70	YRF	107 YR77	63M1-4	210
0.35	2270	3896	36500	1.90				
0.45	1880	3039	36900	2.3				
0.35	2470	3918	36200	1.75				
0.41	2110	3343	36700	2.0				
0.45	1910	3034	36900	2.3	YR	107 YR77	63M1-4	195
0.52	1670	2653	37100	2.6	YRF	107 YR77	63M1-4	200
0.61	1440	2280	37300	3.0				
0.67	1300	2067	37400	3.3				
0.30	3050	4559	17700	1.00	YR	97 YR57	63M1-4	130
0.34	2570	4004	23700	1.15	YRF	97 YR57	63M1-4	145
0.40	2270	3481	25200	1.30				
0.29	3240	4678	4840	0.95				
0.32	2980	4309	20400	1.00				
0.37	2560	3702	23700	1.15				
0.46	2080	3019	26100	1.45	YR	97YR57	63M1-4	125
0.52	1810	2668	27100	1.65	YRF	97YR57	63M1-4	145
0.61	1480	2245	27700	2.0				
0.68	1310	2016	27900	2.3				
0.80	1200	1733	28000	2.5				



技术参数

Technical Data

P ₁ = 0.12 kW								
N _A rpm	M ₂ Nm	i	Fr ₂ MAX[N]	f _s	Type	Gear unit	Motor size	 Kg
0.45	2120	3065	25900	1.40				
0.51	1880	2722	26800	1.60				
0.60	1590	2311	27500	1.90				
0.66	1430	2078	27700	2.1	YR	97 YR57	63M1-4	130
0.76	1240	1823	28000	2.4	YRF		63M1-4	145
0.87	1070	1583	28200	2.8				
0.99	910	1396	28300	3.3				
1.1	775	1228	28400	3.9				
0.48	1770	2873	15200	0.90	YR	87 YR57	63M1-4	86
0.70	1300	1961	18500	1.20	YRF	87 YR57	63M1-4	93
0.53	1790	2595	15000	0.85				
0.65	1430	2129	17700	1.10	YR	87 YR57	63M1-4	85
0.72	1270	1930	18600	1.20	YRF	87 YR57	63M1-4	92
0.80	1120	1733	19300	1.40				
0.79	1150	1737	19200	1.35				
0.91	1010	1524	19800	1.55				
1.1	810	1303	20000	1.90				
1.2	710	1143	20000	2.2	YR	87 YR57	63M1-4	85
1.6	585	885	20000	2.7	YRF	87 YR57	63M1-4	92
1.8	515	776	20000	3.0				
2.0	450	685	20000	3.4				
2.3	360	599	20000	4.3				
1.1	940	1303	8660	0.85				
1.2	800	1124	10100	1.05	YR	77 YR37	63M1-4	45
1.3	740	1047	10600	1.10	YRF	77 YR37	63M1-4	51
1.5	640	915	11300	1.30				
1.1	820	1218	9910	1.00				
1.3	740	1084	10600	1.10				
1.5	665	940	11200	1.25	YR	77 YR37	63M1-4	46
1.7	525	821	12000	1.55	YRF	77 YR37	63M1-4	52
1.9	480	731	12200	1.70				
2.1	460	646	12300	1.80				
2.6	380	520	12600	2.2				
3.1	325	451	12700	2.5	YR	77 YR37	63M1-4	45
3.3	300	422	12800	2.7	YRF	77 YR37	63M1-4	51
3.8	255	365	12900	3.2				
1.6	630	891	7190	0.95				
1.9	505	730	8530	1.20	YR	67 YR37	63M1-4	40
2.1	440	644	9060	1.35	YRF	67 YR37	63M1-4	43
2.4	385	571	9430	1.55				
2.8	320	486	9790	1.85				



技术参数

Technical Data

P ₁ = 0.12 kW								
NA rpm	M ₂ Nm	i	Fr ₂ MAX[N]	f _s	Type	Gear unit	Motor size	 Kg
1.7	590	836	7670	1.00				
1.8	495	750	8630	1.20				
2.1	440	646	9050	1.35	YR	67 YR37	63M1-4	41
2.4	400	574	9330	1.50	YRF	67 YR37	63M1-4	44
2.8	345	495	9660	1.75				
3.1	285	438	9940	2.1				
1.8	550	782	4650	0.80				
2.0	455	678	7070	1.00				
2.3	415	604	7260	1.10	YR	57 YR37	63M1-4	34
2.6	375	537	7400	1.20	YRF	57 YR37	63M1-4	38
2.9	330	471	7550	1.35				
3.9	245	357	7770	1.85				
4.3	215	319	7830	2.1				
3.8	260	359	7730	1.75				
4.3	235	324	7790	1.95				
4.8	205	290	7840	2.2	YR	57 YR37	63M1-4	33
5.3	185	262	7880	2.4	YRF	57 YR37	63M1-4	37
5.6	171	246	7900	2.6				
6.3	150	220	7930	3.0				
2.7	345	510	4360	0.85				
3.2	285	436	5490	1.05	YR	47 YR37	63M1-4	28
3.4	265	408	5590	1.10	YRF	47 YR37	63M1-4	28
4.0	220	344	5790	1.35				
2.8	365	502	3020	0.80				
3.2	315	429	5350	0.95				
3.7	270	372	5580	1.10				
4.0	250	348	5670	1.20	YR	47 YR37	63M1-4	28
4.6	210	301	5810	1.40	YRF	47 YR37	63M1-4	28
5.4	177	255	5930	1.70				
6.0	156	228	5980	1.95				
7.1	130	195	6040	2.3				
4.1	225	338	4570	0.90				
4.7	210	296	4790	0.95				
5.3	184	259	5130	1.10	YR	37 YR17	63M1-4	17
6.0	163	228	5360	1.25	YRF	37 YR17	63M1-4	19
6.9	140	199	5550	1.40				
8.0	123	172	5680	1.65				
4.2	240	328	3730	0.85				
4.8	205	289	4880	1.00				
5.2	192	265	5040	1.05	YR	37 YR17	63M1-4	17
6.1	156	226	5410	1.30	YRF	37 YR17	63M1-4	18
6.8	144	202	5530	1.40				
7.7	125	179	5660	1.60				



技术参数

Technical Data

P ₁ = 0.12 kW								
NA rpm	M ₂ Nm	i	Fr ₂ MAX[N]	f _s	Type	Gear unit	Motor size	 Kg
6.0	158	229	4090	0.80				
6.9	138	200	4200	0.95	YR	27 YR17	63M1-4	11
7.8	121	177	4270	1.05	YRF	27 YR17	63M1-4	11
8.3	116	166	4290	1.10				
6.1	157	227	4100	0.85				
6.8	144	203	4170	0.90	YR	27 YR17	63M1-4	11
7.7	125	179	4260	1.05	YRF	27 YR17	63M1-4	11
8.8	106	156	4330	1.25				
4.6	250	195.24	12900	3.3	YR	77	Y7116	37
5.4	210	166.59	13000	3.9	YRF	77	Y7116	43
6.2	186	145.67	13000	4.4				
4.5	255	199.81	10100	2.4				
4.9	235	184.07	10100	2.6				
5.7	200	158.14	10300	3.0	YR	67	Y7116	30
6.5	175	137.67	10300	3.4	YRF	67	Y7116	33
7.0	164	128.97	10400	3.7				
7.9	145	113.94	10400	4.1				
6.9	166	199.81	10300	3.6	YR	67	63M1-4	30
7.5	153	184.07	10400	3.9	YRF	67	63M1-4	33
4.8	240	186.89	7780	1.90				
5.2	220	172.17	7820	2.1				
6.1	188	147.92	7870	2.4	YR	57	Y7116	23
7.0	164	128.77	7910	2.7	YRF	57	Y7116	27
7.5	154	120.63	7920	2.9				
8.4	136	106.58	7950	3.3				
9.1	126	98.99	7960	3.6				
7.4	155	186.89	7920	2.9				
8.0	143	172.17	7940	3.2	YR	57	63M1-4	23
9.3	123	147.92	7960	3.7	YRF	57	63M1-4	27
11	107	128.77	7980	4.2				
5.1	225	176.88	5760	1.35				
5.5	210	162.94	5830	1.45	YR	47	Y7116	18
6.4	178	139.99	5920	1.70	YRF	47	Y7116	18
7.4	155	121.87	5980	1.95				
7.8	147	176.88	6000	2.0				
8.5	135	162.94	6030	2.2				
9.9	116	139.99	6070	2.6	YR	47	63M1-4	18
11	101	121.87	6100	3.0	YRF	47	63M1-4	18
12	95	114.17	6110	3.2				
14	84	100.86	6120	3.6				
15	78	93.68	6130	3.9				



技术参数

Technical Data

P ₁ = 0.12 kW								
N _A rpm	M ₂ Nm	i	Fr ₂ MAX[N]	f _s	Type	Gear unit	Motor size	 Kg
6.7	172	134.82	5270	1.15				
7.3	157	123.66	5410	1.25				
8.6	134	105.28	5600	1.50	YR	37	Y7116	14
9.9	116	90.77	5730	1.75	YRF	37	Y7116	16
11	108	84.61	5770	1.85				
12	94	73.96	5850	2.1				
10	112	134.82	5750	1.80				
11	103	123.66	5800	1.95				
13	87	105.28	5880	2.3	YR	37	63M1-4	14
15	75	90.77	5930	2.7	YRF	37	63M1-4	16
16	70	84.61	5950	2.8				
19	61	73.96	5980	3.3				
7.3	158	123.91	4090	0.80				
8.5	134	105.49	4210	0.95	YR	27	Y7116	8.3
9.9	116	90.96	4300	1.10	YRF	27	Y7116	8.2
11	108	84.78	4330	1.20				
12	94	74.11	4370	1.40				
10	112	135.09	4310	1.15				
11	103	123.91	4340	1.25				
13	88	105.49	4390	1.50				
15	76	90.96	4430	1.70				
16	70	84.78	4440	1.85	YR	27	63M1-4	8.3
19	62	74.11	4460	2.1	YRF	27	63M1-4	8.2
20	58	69.47	4470	2.3				
23	51	61.30	4400	2.6				
25	46	55.87	4280	2.8				
29	40	48.17	4090	3.3				
31	37	44.90	4000	3.5				
11	104	81.64	1300	0.80				
13	90	70.39	1470	0.95				
14	84	65.61	1860	1.00	YR	17	Y7116	7.6
16	73	57.35	2430	1.15	YRF	17	Y7116	7.5
17	68	53.76	2500	1.25				
19	60	47.44	2500	1.40				
17	68	81.64	2500	1.25				
20	58	70.39	2500	1.45				
21	55	65.61	2500	1.55				
24	48	57.35	2500	1.80				
26	45	53.76	2500	1.90	YR	17	63M1-4	7.6
29	39	47.44	2500	2.2	YRF	17	63M1-4	7.5
31	37	44.18	2500	2.3				
36	32	38.61	2430	2.7				
38	30	36.20	2390	2.8				
43	27	31.94	2310	3.2				



技术参数

Technical Data

P₁ = 0.12 kW								
--------------------------------	--	--	--	--	--	--	--	--

N _A rpm	M ₂ Nm	i	Fr ₂ MAX[N]	f _s	Type	Gear unit	Motor size	Kg
49	24	28.32	2230	3.6	YR	17	63M1-4	7.6
57	20	24.07	2130	4.3	YRF	17	63M1-4	7.5
227	5.0	6.07	4270	8.6				
267	4.3	5.18	4050	17	YRX	67	63M1-4	16
305	3.8	4.53	3870	22	YRXF	67	63M1-4	20
321	3.6	4.30	3810	22				
251	4.6	5.50	3360	8.5				
272	4.2	5.07	3270	8.6				
317	3.6	4.35	3120	19				
364	3.1	3.79	2980	22				
389	2.9	3.55	2910	24				
440	2.6	3.14	2800	25	YRX	57	63M1-4	14
474	2.4	2.91	2730	28	YRXF	57	63M1-4	16
523	2.2	2.64	2640	31				
582	2.0	2.37	2550	35				
676	1.7	2.04	2430	41				
719	1.6	1.92	2380	43				
835	1.4	1.65	2260	49				

P₁ = 0.18 kW								
--------------------------------	--	--	--	--	--	--	--	--

0.09	15000	14075	50900	0.85				
0.11	13100	12344	62500	1.00	YR	147 YR77	63M2-4	420
0.12	11600	11143	65200	1.10	YRF	147 YR77	63M2-4	430
0.14	10300	9743	67300	1.25				
0.16	8550	8443	69700	1.50				
0.18	7400	7307	70900	1.75				
0.20	6530	6447	71800	2.0				
0.24	5640	5568	72500	2.3	YR	147 YR77	63M2-4	420
0.27	5150	4926	72800	2.5	YRF	147 YR77	63M2-4	430
0.31	4420	4325	73300	2.9				
0.35	3920	3754	73600	3.3				
0.40	3380	3302	73800	3.9				
0.15	8900	8784	50100	0.90				
0.18	7390	7479	54600	1.10				
0.20	6950	6559	55500	1.15	YR	137 YR77	63M2-4	290
0.23	5770	5834	57400	1.40	YRF	137 YR77	63M2-4	310
0.26	5420	5116	57900	1.50				
0.30	4520	4464	59000	1.75				
0.34	3980	3928	59500	2.0				
0.28	5060	4709	58300	1.60	YR	137 YR77	63M2-4	280
0.33	4320	4018	59200	1.85	YRF	137 YR77	63M2-4	300
0.38	3780	3514	59700	2.1				



技术参数

Technical Data

P ₁ = 0.18 kW								
N _A rpm	M ₂ Nm	i	Fr ₂ MAX[N]	f _s	Type	Gear unit	Motor size	 Kg
0.40	3590	3338	59900	2.2	YR	137 YR77	63M2-4	280
0.45	3150	2929	60200	2.5	YRF	137 YR77	63M2-4	300
0.30	4490	4435	28400	0.95	R	107 YR77	63M2-4	200
0.34	3980	3896	31100	1.10	YRF	107 YR77	63M2-4	210
0.43	3220	3039	34200	1.35				
0.34	4210	3918	29900	1.00				
0.39	3590	3343	32800	1.20				
0.44	3260	3034	34100	1.30	YR	107 YR77	63M2-4	195
0.50	2850	2653	35400	1.50	YRF	107 YR77	63M2-4	200
0.58	2450	2280	36200	1.75				
0.64	2220	2067	36500	1.95				
0.66	2100	1987	36700	2.1				
0.72	1870	1827	36900	2.3	YR	107 YR77	63M2-4	200
0.83	1600	1599	37200	2.7	YRF	107 YR77	63M2-4	205
0.94	1440	1400	37300	3.0				
1.1	1230	1226	37400	3.5				
0.49	3000	2668	20000	1.00				
0.59	2480	2245	24200	1.20				
0.65	2210	2016	25500	1.35				
0.76	1970	1733	26500	1.50				
0.81	1840	1623	27000	1.65				
0.92	1610	1434	27500	1.85	YR	97 YR57	63M2-4	125
1.1	1330	1207	27900	2.3	YRF	97 YR57	63M2-4	145
1.2	1190	1084	28000	2.5				
1.4	1000	934	28200	3.0				
1.5	940	878	28300	3.2				
1.8	790	755	28400	3.8				
0.49	3090	2722	15900	0.95	YR	97 YR57	63M2-4	130
0.57	2620	2311	23400	1.15	YRF	97 YR57	63M2-4	145
0.64	2360	2078	24800	1.25				
0.89	1690	1489	15900	0.90				
0.95	1580	1395	16700	1.00				
1.1	1380	1232	18000	1.10	YR	87 YR57	63M2-4	85
1.2	1280	1145	18600	1.20	YRF	87 YR57	63M2-4	92
1.3	1150	1037	19200	1.35				
1.4	1020	931	19800	1.50				
1.7	860	802	20000	1.80				
0.87	1680	1524	15900	0.90				
1.0	1390	1303	17900	1.10	YR	87 YR57	63M2-4	85
1.2	1220	1143	18900	1.25	YRF	87 YR57	63M2-4	92
1.5	980	885	19900	1.60				
1.7	860	776	20000	1.80				



技术参数

Technical Data

P ₁ = 0.18 kW								
NA rpm	M ₂ Nm	i	Fr ₂ MAX[N]	f _s	Type	Gear unit	Motor size	 Kg
1.5	980	858	5830	0.85				
1.7	850	757	9590	0.95	YR	77 YR37	63M2-4	45
2.0	750	671	10500	1.10	YRF	77 YR37	63M2-4	51
2.3	630	571	11400	1.30				
1.6	890	821	9230	0.90				
1.8	800	731	10100	1.00				
2.0	745	646	10500	1.10				
2.4	645	560	11300	1.25	YR	77 YR37	63M2-4	46
2.7	550	488	11800	1.50	YRF	77 YR37	63M2-4	52
3.0	490	436	12100	1.70				
3.5	420	373	12400	1.95				
4.0	370	327	12600	2.2				
4.6	330	289	12700	2.5				
2.3	640	571	7060	0.95	YR	67 YR37	63M2-4	40
2.7	535	486	8250	1.10	YRF	67 YR37	63M2-4	43
2.3	655	574	5820	0.90				
2.7	565	495	7950	1.05				
3.0	480	438	8740	1.25	YR	67 YR37	63M2-4	41
3.4	425	388	9160	1.40	YRF	67 YR37	63M2-4	44
3.8	395	344	9380	1.55				
4.5	320	294	9800	1.90				
5.1	290	261	9920	2.1				
2.9	500	454	6650	0.90	YR	57 YR37	63M2-4	33
3.2	455	410	7090	1.00	YRF	57 YR37	63M2-4	37
2.8	540	471	5250	0.85				
3.7	405	357	7300	1.10				
4.1	355	319	7460	1.25	YR	57 YR37	63M2-4	34
4.8	300	273	7630	1.50	YRF	57 YR37	63M2-4	38
5.5	260	241	7730	1.75				
6.1	235	215	7790	1.95				
3.7	420	359	7230	1.05				
4.1	380	324	7380	1.20				
4.5	335	290	7530	1.35				
5.0	305	262	7620	1.50	YR	57 YR37	63M2-4	33
5.4	280	246	7680	1.60	YRF	57 YR37	63M2-4	37
6.0	250	220	7750	1.80				
7.0	210	188	7830	2.1				
8.3	177	159	7890	2.6				
4.4	350	301	4150	0.85				
5.2	290	255	5460	1.05	YR	47 YR37	63M2-4	28
5.8	260	228	5630	1.15	YRF	47 YR37	63M2-4	28
6.8	220	195	5790	1.40				



技术参数

Technical Data

P ₁ = 0.18 kW									
NA rpm	M ₂ Nm	i	Fr ₂ MAX[N]	f _s	Type	Gear unit	Motor size	Kg	
6.6	230	199	4510	0.85	YR	37 YR17	63M2-4	17	
7.7	199	172	4960	1.00	YRF	37 YR17	63M2-4	19	
8.8	173	150	5260	1.15					
6.5	235	202	4050	0.85	YR	37 YR17	63M2-4	17	
7.4	205	179	4870	0.95	YRF	37 YR17	63M2-4	18	
8.5	176	156	5230	1.15					
9.4	157	141	4100	0.85					
11	139	124	4190	0.95	YR	27 YR17	63M2-4	11	
12	125	110	4260	1.05	YRF	27 YR17	63M2-4	11	
14	105	94	4340	1.25					
9.8	152	135	4120	0.85					
11	139	118	4190	0.95	YR	27 YR17	63M2-4	11	
13	121	104	4270	1.10	YRF	27 YR17	63M2-4	11	
15	105	90	4340	1.25					
4.5	385	195.24	12500	2.1	YR	77	63M2-4	38	
5.2	330	166.59	12700	2.5	YRF	77	63M2-4	43	
6.0	290	145.67	12800	2.9	YR	77	63M2-4	38	
6.3	275	138.39	12900	3.0	YRF	77	63M2-4	43	
7.2	240	121.42	12900	3.4					
6.8	255	195.24	12900	3.2					
7.9	215	166.59	13000	3.8	YR	77	63M2-4	37	
9.1	190	145.67	13000	4.3	YRF	77	63M2-4	43	
9.5	180	138.39	13000	4.6					
4.4	395	199.81	9370	1.50					
4.7	365	184.07	9560	1.65					
5.5	310	158.14	9830	1.90					
6.3	270	137.67	10000	2.2					
6.8	255	128.97	10100	2.4	YR	67	63M2-4	31	
7.6	225	113.94	10200	2.7	YRF	67	63M2-4	34	
8.2	210	105.83	10200	2.9					
9.1	190	95.91	10300	3.2					
10	170	86.11	10300	3.5					
12	147	74.17	10400	4.1					
12	138	69.75	10400	4.4					
6.6	260	199.81	10100	2.3					
7.2	240	184.07	10100	2.5					
8.3	205	158.14	10200	2.9	YR	67	63M2-4	30	
9.6	179	137.67	10300	3.4	YRF	67	63M2-4	33	
10	168	128.97	10300	3.6					
12	148	113.94	10400	4.0					
12	138	105.83	10400	4.4					



技术参数

Technical Data

P ₁ = 0.18 kW								
NA rpm	M ₂ Nm	i	Fr ₂ MAX[N]	f _s	Type	Gear unit	Motor size	 Kg
4.7	370	186.89	7420	1.20	YR YRF	57	71M1-6	24
5.0	340	172.17	7510	1.30				
5.9	290	147.92	7650	1.55				
6.8	255	128.77	7740	1.75				
7.2	240	120.63	7780	1.90				
7.1	245	186.89	7770	1.85	YR YRF	57	63M2-4	23
7.7	225	172.17	7810	2.0				
8.9	193	147.92	7870	2.3				
10	168	128.77	7900	2.7				
11	157	120.63	7920	2.9				
12	139	106.58	7940	3.2				
13	129	98.99	7950	3.5				
15	117	89.71	7970	3.9				
7.5	230	176.88	5740	1.30	YR YRF	47	63M2-4	18
8.1	210	162.94	5810	1.40				
9.4	182	139.99	5910	1.65				
11	159	121.87	5980	1.90				
12	149	114.17	6000	2.0				
13	131	100.86	6040	2.3				
14	122	93.68	6060	2.5				
16	111	84.90	6080	2.7				
17	99	76.23	6100	3.0				
7.0	245	123.66	3060	0.80	YR YRF	37	63M2-4	15
8.3	210	105.28	4840	0.95				
9.6	179	90.77	5190	1.10				
10	167	84.61	5310	1.20				
9.8	176	134.82	5230	1.15	YR YRF	37	63M2-4	14
11	161	123.66	5370	1.25				
13	137	105.28	5580	1.45				
15	118	90.77	5710	1.70				
16	110	84.61	5760	1.80				
18	96	73.96	5840	2.1				
19	90	69.33	5870	2.2				
22	80	61.18	5920	2.5				
24	73	55.76	5940	2.8				
27	63	48.08	5960	3.2				
11	161	123.91	4070	0.80	YR YRF	27	63M2-4	8.3
13	137	105.49	4200	0.95				
15	118	90.96	4280	1.10				
16	110	84.78	4320	1.20				
18	97	74.11	4370	1.35				
19	91	69.47	4380	1.45				
22	80	61.30	4320	1.65				
24	73	55.87	4210	1.80				



技术参数

Technical Data

P ₁ = 0.18 kW								
N _A rpm	M ₂ Nm	i	Fr ₂ MAX[N]	f _s	Type	Gear unit	Motor size	 Kg
27	63	48.17	4040	2.1				
29	59	44.90	3960	2.2				
34	51	39.25	3810	2.5	YR	27	63M2-4	8.3
36	48	36.79	3740	2.7	YRF	27	63M2-4	8.2
41	42	32.47	3610	3.1				
46	38	28.78	3480	3.5				
54	32	24.47	3310	4.1				
47	37	28.37	3470	3.5				
51	34	26.09	3380	3.8				
59	29	22.32	3220	4.5	YR	27	63M2-4	8.0
68	25	19.35	3090	5.2	YRF	27	63M2-4	7.9
73	24	18.08	3020	5.5				
84	20	15.63	2890	6.4				
99	17	13.28	2750	7.5				
16	106	81.64	1330	0.80				
19	92	70.39	1330	0.95				
20	85	65.61	1740	1.00				
23	75	57.35	2350	1.15				
25	70	53.76	2500	1.20				
28	62	47.44	2450	1.40	YR	17	63M2-4	7.6
30	58	44.18	2410	1.50	YRF	17	63M2-4	7.5
34	50	38.61	2340	1.70				
36	47	36.20	2300	1.80				
41	42	31.94	2240	2.0				
47	37	28.32	2170	2.3				
55	31	24.07	2080	2.7				
52	33	25.23	2110	2.6				
57	30	23.15	2060	2.8	YR	17	63M2-4	7.3
67	26	19.71	1970	3.3	YRF	17	63M2-4	7.2
78	22	16.99	1890	3.9				
143	12	6.07	4940	3.6				
168	10	5.18	4690	7.4	YRX	67	71M1-6	17
192	8.9	4.53	4490	9.2	YRXF	67	71M1-6	21
202	8.5	4.30	4410	9.4				
218	7.9	6.07	4310	5.4				
255	6.7	5.18	4090	11				
292	5.9	4.53	3920	14				
307	5.6	4.30	3850	14				
350	4.9	3.77	3690	18	YRX	67	63M2-4	16
413	4.2	3.20	3500	24	YRXF	67	63M2-4	20
457	3.8	2.89	3380	28				
519	3.3	2.54	3240	36				
550	3.1	2.40	3180	40				
646	2.7	2.04	3020	50				



技术参数

Technical Data

P₁ = 0.18 kW								
--------------------------------	--	--	--	--	--	--	--	--

N _A rpm	M ₂ Nm	i	Fr ₂ MAX[N]	f _s	Type	Gear unit	Motor size	Kg
158	11	5.50	3880	3.6				
172	10	5.07	3780	3.6	YRX	57	71M1-6	14
200	8.6	4.35	3600	7.9	YRXF	57	71M1-6	16
230	7.5	3.79	3440	9.2				
<hr/>								
240	7.2	5.50	3400	5.4				
261	6.6	5.07	3310	5.5				
303	5.7	4.35	3150	12				
348	4.9	3.79	3010	14				
372	4.6	3.55	2950	15				
421	4.1	3.14	2830	16	YRX	57	63M2-4	14
453	3.8	2.91	2760	18	YRXF	57	63M2-4	16
500	3.4	2.64	2670	20				
557	3.1	2.37	2580	22				
647	2.7	2.04	2460	26				
688	2.5	1.92	2410	28				
799	2.2	1.65	2290	31				

P₁ = 0.25 kW								
--------------------------------	--	--	--	--	--	--	--	--

0.13	15200	9743	48200	0.85				
0.15	12800	8443	63100	1.00				
0.18	11000	7307	66200	1.20				
0.20	9740	6447	68100	1.35				
0.23	8410	5568	69800	1.55	YR	147 YR77	71M1-4	420
0.26	7600	4926	70700	1.70	YRF	147 YR77	71M1-4	430
0.30	6570	4325	71700	2.0				
0.35	5790	3754	72400	2.3				
0.39	5020	3302	72900	2.6				
0.45	4380	2898	73300	3.0				
<hr/>								
0.22	8670	5834	51100	0.90				
0.25	7970	5116	53500	1.00	YR	137 YR77	71M1-4	290
0.29	6740	4464	55800	1.20	YRF	137 YR77	71M1-4	310
0.33	5930	3928	57100	1.35				
<hr/>								
0.28	7430	4709	54600	1.10				
0.32	6340	4018	56500	1.25				
0.37	5550	3514	57700	1.45	YR	137 YR77	71M1-4	280
0.39	5270	3338	58100	1.50	YRF	137 YR77	71M1-4	300
0.44	4620	2929	58900	1.75				
<hr/>								
0.49	4190	2658	59300	1.90				
0.54	3800	2412	59700	2.1				
0.63	3270	2073	60100	2.5	YR	137 YR77	71M1-4	290
0.71	2810	1839	60500	2.8	YRF	137 YR77	71M1-4	310
0.93	2180	1397	60800	3.7				
1.1	1890	1226	61000	4.2				



技术参数

Technical Data

P ₁ = 0.25 kW								
N _A rpm	M ₂ Nm	i	Fr ₂ MAX[N]	f _s	Type	Gear unit	Motor size	 Kg
0.43	4730	3039	25600	0.90	YR	107 YR77	71M1-4	205
					YRF	107 YR77	71M1-4	210
0.43	4790	3034	23600	0.90	YR	107 YR77	71M1-4	195
					YRF	107 YR77	71M1-4	200
0.65	3100	1987	34600	1.40	YR YRF	107 YR77	71M1-4	200 205
0.71	2790	1827	35600	1.55				
0.81	2410	1599	36300	1.80				
0.93	2140	1400	36600	2.0				
1.1	1840	1226	36900	2.3				
1.4	1440	939	37300	3.0				
1.6	1240	822	37400	3.5				
0.75	2840	1733	22000	1.05	YR	97 YR57	71M1-4	125
0.80	2660	1623	23200	1.15	YRF	97 YR57	71M1-4	145
0.71	2960	1823	21100	1.00	YR YRF	97 YR57	71M1-4	130 145
0.82	2570	1583	23700	1.15				
0.93	2230	1396	25400	1.35				
1.1	1940	1228	26600	1.55				
1.2	1750	1069	27300	1.70				
1.4	1530	938	27600	1.95				
1.6	1300	824	27900	2.3				
1.8	1160	737	28100	2.6				
2.1	1000	632	28200	3.0				
1.1	1850	1145	10700	0.85	YR YRF	87 YR57	71M1-4	85 93
1.2	1670	1037	16000	0.95				
1.4	1490	931	17400	1.05				
1.6	1270	802	18600	1.20				
1.1	1800	1143	14700	0.85	YR YRF	87 YR57	71M1-4	86 93
1.5	1420	885	17800	1.10				
1.7	1250	776	18700	1.25				
1.9	1100	685	19400	1.40				
2.2	930	599	20000	1.65				
2.5	820	525	20000	1.90				
2.9	715	456	20000	2.2				
4.9	415	268	20000	3.7				
2.3	920	571	8910	0.90	YR	77 YR37	71M1-4	46
					YRF	77 YR37	71M1-4	52
2.3	930	560	8780	0.90	YR YRF	77 YR37	71M1-4	47 53
2.7	795	488	10100	1.05				
3.0	705	436	10900	1.15				
3.5	610	373	11500	1.35				
4.0	535	327	11900	1.55				
4.5	475	289	12200	1.75				



技术参数

Technical Data

P ₁ = 0.25 kW								
NA rpm	M ₂ Nm	i	Fr ₂ MAX[N]	f _s	Type	Gear unit	Motor size	 Kg
5.0	425	260	12400	1.95	YR	77 YR37	71M1-4	47
5.8	355	224	12600	2.3	YRF	77 YR37	71M1-4	53
3.4	620	388	7290	0.95				
3.8	565	344	7950	1.05				
4.4	465	294	8870	1.30				
5.0	425	261	9180	1.40	YR	67 YR37	71M1-4	41
5.5	380	234	9460	1.60	YRF	67 YR37	71M1-4	45
6.5	320	200	9780	1.85				
7.4	280	176	9980	2.2				
8.2	250	158	10100	2.4				
3.4	645	384	6960	0.95				
3.6	600	359	7550	1.00				
4.2	515	310	8430	1.15				
4.9	435	264	9100	1.40	YR	67 YR37	71M1-4	41
5.5	385	235	9420	1.55	YRF	67 YR37	71M1-4	44
6.5	325	201	9750	1.85				
7.2	295	181	9910	2.0				
4.1	520	319	6050	0.85				
4.8	440	273	7160	1.05				
5.4	380	241	7380	1.20	YR	57 YR37	71M1-4	35
6.0	340	215	7510	1.30	YRF	57 YR37	71M1-4	38
7.0	300	187	7630	1.50				
7.9	260	164	7730	1.75				
9.2	225	142	7800	2.0				
4.0	545	324	4980	0.85				
4.5	485	290	6950	0.95	YR	57 YR37	71M1-4	34
5.0	435	262	7160	1.05	YRF	57 YR37	71M1-4	37
5.3	405	246	7280	1.10				
5.9	360	220	7450	1.25				
5.7	375	228	2440	0.80				
6.7	315	195	5320	0.95	YR	47 YR37	71M1-4	29
7.1	295	182	5440	1.00	YRF	47 YR37	71M1-4	29
8.5	245	154	5680	1.20				
8.7	250	150	2540	0.80				
10	210	130	4790	0.95				
10	200	124	4930	1.00	YR	37 YR17	71M1-4	18
12	178	110	5200	1.10	YRF	37 YR17	71M1-4	19
14	152	94	5460	1.30				
9.7	220	135	4660	0.90				
10	215	127	4770	0.95	YR	37 YR17	71M1-4	18
13	174	104	5250	1.15	YRF	37 YR17	71M1-4	19
14	150	90	5470	1.35				



技术参数

Technical Data

P ₁ = 0.25 kW								
NA rpm	M ₂ Nm	i	Fr ₂ MAX[N]	f _s	Type	Gear unit	Motor size	 Kg
2.4	1020	289.74	28200	3.0				
2.7	900	255.71	28300	3.3	YR	97	71M2-6	110
2.8	850	241.25	28400	3.5	YRF	97	71M2-6	125
3.1	760	216.28	28400	4.0				
2.8	870	246.54	20000	1.8				
3.1	760	216.54	20000	2.0	YR	87	80M2-8	68
3.3	720	205.71	20000	2.2	YRF	87	80M2-8	75
3.7	640	181.77	20000	2.4				
4.1	585	166.59	11600	1.40				
4.7	510	145.67	12000	1.60	YR	77	80M2-8	42
4.9	485	138.39	12100	1.70	YRF	77	80M2-8	48
5.6	425	121.42	12400	1.90				
4.5	530	195.24	11900	1.55	YR	77	71M2-6	38
5.3	450	166.59	12300	1.80	YRF	77	71M2-6	44
6.0	395	145.67	12500	2.1				
6.7	360	195.24	12600	2.3				
7.8	305	166.59	12800	2.7	YR	77	71M2-4	38
8.9	270	145.67	12900	3.1	YRF	77	71M2-4	43
9.4	255	138.39	12900	3.2				
11	225	121.42	13000	3.7				
4.3	555	158.14	8060	1.10				
4.9	485	137.67	8730	1.25	YR	67	80M2-8	35
5.3	455	128.97	8970	1.35	YRF	67	80M2-8	38
6.0	400	113.94	9340	1.50				
4.4	540	199.81	8190	1.10				
4.8	500	184.07	8590	1.20				
5.6	430	158.14	9140	1.40	YR	67	71M2-6	32
6.4	375	137.67	9500	1.60	YRF	67	71M2-6	35
6.8	350	128.97	9630	1.70				
7.7	310	113.94	9840	1.95				
8.3	285	105.83	9940	2.1				
6.5	365	199.81	9540	1.65				
7.1	340	184.07	9700	1.80				
8.2	290	158.14	9930	2.1				
9.4	255	137.67	10100	2.4	YR	67	71M2-4	31
10	235	128.97	10100	2.5	YRF	67	71M2-4	34
11	210	113.94	10200	2.9				
12	194	105.83	10300	3.1				
14	176	95.91	10300	3.4				
15	158	86.11	10400	3.8				
4.7	505	186.89	6450	0.90	YR	57	71M2-6	25
5.1	465	172.17	7030	0.95	YRF	57	71M2-6	29



技术参数

Technical Data

P ₁ = 0.25 kW								
N _A rpm	M ₂ Nm	i	Fr ₂ MAX[N]	f _s	Type	Gear unit	Motor size	 Kg
6.0	400	147.92	7300	1.10				
6.8	350	128.77	7480	1.30	YR	57	71M2-6	25
7.3	325	120.63	7550	1.35	YRF	57	71M2-6	29
8.3	290	106.58	7660	1.55				
8.9	270	98.99	7710	1.70				
7.0	345	186.89	7500	1.30				
7.5	315	172.17	7590	1.40				
8.8	270	147.92	7700	1.65				
10	235	128.77	7780	1.90				
11	220	120.63	7810	2.0	YR	57	71M1-4	24
12	196	106.58	7860	2.3	YRF	57	71M1-4	27
13	182	98.99	7880	2.5				
14	165	89.71	7910	2.7				
16	148	80.55	7930	3.0				
19	127	69.23	7960	3.5				
7.4	325	176.88	5280	0.90				
8.0	300	162.94	5420	1.00				
9.3	255	139.99	5630	1.15				
11	225	121.87	5770	1.35				
11	210	114.17	5820	1.45				
13	185	100.86	5900	1.60				
14	172	93.68	5940	1.75	YR	47	71M1-4	15
15	156	84.90	5980	1.90	YRF	47	71M1-4	16
17	140	76.23	6020	2.1				
19	126	68.54	6050	2.4				
20	118	64.21	6070	2.5				
23	104	56.73	6090	2.9				
25	97	52.69	6100	3.1				
27	88	47.75	6080	3.4				
9.6	250	134.82	2630	0.80				
11	225	123.66	4560	0.90				
12	193	105.28	5030	1.05				
14	167	90.77	5320	1.20				
15	155	84.61	5420	1.30				
18	136	73.96	5590	1.45				
19	127	69.33	5650	1.55	YR	37	71M1-4	15
21	112	61.18	5750	1.80	YRF	37	71M1-4	16
23	102	55.76	5800	1.95				
27	88	48.08	5870	2.3				
29	82	44.81	5760	2.4				
33	72	39.17	5540	2.8				
35	67	36.72	5430	3.0				
40	60	32.40	5230	3.4				



技术参数

Technical Data

P ₁ = 0.25 kW								
NA rpm	M ₂ Nm	i	Fr ₂ MAX[N]	f _s	Type	Gear unit	Motor size	 Kg
15	156	84.78	4100	0.85				
18	136	74.11	4210	0.95				
19	128	69.47	4250	1.00				
21	113	61.30	4190	1.15				
23	103	55.87	4090	1.25				
27	89	48.17	3940	1.45	YR	27	71M1-4	9.0
29	83	44.90	3870	1.60	YRF	27	71M1-4	8.9
33	72	39.25	3730	1.80				
35	68	36.79	3670	1.90				
40	60	32.47	3540	2.2				
45	53	28.78	3420	2.5				
53	45	24.47	3270	2.9				
46	52	28.37	3410	2.5				
50	48	26.09	3330	2.7				
58	41	22.32	3180	3.2				
67	36	19.35	3050	3.7				
72	33	18.08	2990	3.9				
83	29	15.63	2860	4.5				
98	24	13.28	2730	5.3				
110	22	11.86	2630	5.9				
128	19	10.13	2510	6.6	YR	27	71M1-4	8.7
138	17	9.41	2440	7.1	YRF	27	71M1-4	8.6
159	15	8.16	2330	7.7				
170	14	7.63	2290	8.0				
197	12	6.59	2180	8.8				
232	10	5.60	2080	9.6				
260	9.2	5.00	2000	10				
304	7.8	4.27	1910	11				
325	7.3	4.00	1870	12				
386	6.2	3.37	1770	13				
23	105	57.35	156	0.80				
24	99	53.76	785	0.85				
27	87	47.44	1630	1.00				
29	81	44.18	2000	1.05	YR	17	71M1-4	8.3
34	71	38.61	2200	1.20	YRF	17	71M1-4	8.2
36	67	36.20	2180	1.30				
41	59	31.94	2130	1.45				
46	52	28.32	2070	1.65				
54	44	24.07	2000	1.90				
52	46	25.23	2020	1.85				
56	43	23.15	1980	2.0				
66	36	19.71	1910	2.4	YR	17	71M1-4	8.0
77	31	16.99	1840	2.7	YRF	17	71M1-4	7.9
82	29	15.84	1810	2.9				
94	25	13.84	1750	3.4				



技术参数

Technical Data

P ₁ = 0.25 kW								
NA rpm	M ₂ Nm	i	Fr ₂ MAX[N]	f _s	Type	Gear unit	Motor size	 Kg
100	24	12.98	1720	3.6	YR	17	71M1-4	8.0
114	21	11.45	1660	3.9	YRF	17	71M1-4	7.9
145	17	6.07	4890	2.6				
170	14	5.18	4650	5.4	YRX	67	71M2-6	19
194	12	4.53	4450	6.7	YRXF	67	71M2-6	23
205	12	4.30	4380	6.8				
214	11	6.07	4310	3.9				
251	9.5	5.18	4100	7.9				
287	8.3	4.53	3920	9.9				
302	7.9	4.30	3860	10				
345	6.9	3.77	3700	13	YRX	67	71M1-4	17
406	5.9	3.20	3500	17	YRXF	67	71M1-4	21
450	5.3	2.89	3390	20				
511	4.7	2.54	3250	25				
542	4.4	2.40	3190	28				
636	3.8	2.04	3020	35				
160	15	5.50	3840	2.6				
174	14	5.07	3740	2.6	YRX	57	71M2-6	16
202	12	4.35	3560	5.8	YRXF	57	71M2-6	18
232	10	3.79	3410	6.7				
236	10	5.50	3390	3.9				
257	9.3	5.07	3300	3.9				
299	8.0	4.35	3150	8.5				
343	7.0	3.79	3010	9.9				
366	6.5	3.55	2950	11				
414	5.8	3.14	2830	11	YRX	57	71M1-4	14
446	5.3	2.91	2760	13	YRXF	57	71M1-4	16
492	4.8	2.64	2680	14				
548	4.4	2.37	2580	16				
637	3.7	2.04	2460	19				
677	3.5	1.92	2410	20				
787	3.0	1.65	2300	23				

P ₁ = 0.37 kW								
0.19	15900	7307	37500	0.80				
0.21	14100	6447	60400	0.90				
0.25	12100	5568	64300	1.05				
0.28	10900	4926	66400	1.20	YR	147 YR77	71M2-4	420
0.32	9480	4325	68500	1.35	YRF	147 YR77	71M2-4	430
0.37	8310	3754	70000	1.55				
0.42	7240	3302	71100	1.80				
0.48	6320	2898	71900	2.1				



技术参数

Technical Data

P ₁ = 0.37 kW								
N _A rpm	M ₂ Nm	i	Fr ₂ MAX[N]	f _s	Type	Gear unit	Motor size	 Kg
0.31	9740	4464	39400	0.80	YR	137 YR77	71M2-4	290
0.35	8570	3928	51500	0.95	YRF	137 YR77	71M2-4	315
0.34	9080	4018	49200	0.90				
0.39	7940	3514	53500	1.00				
0.41	7540	3338	54300	1.05	YR	137 YR77	71M2-4	280
0.47	6620	2929	56000	1.20	YRF	137 YR77	71M2-4	305
0.56	5600	2484	57600	1.45				
0.62	5030	2242	58400	1.60				
0.52	6000	2658	57000	1.35				
0.57	5440	2412	57800	1.45				
0.67	4680	2073	58800	1.70				
0.75	4060	1839	59400	1.95	YR	137 YR77	71M2-4	290
0.99	3130	1397	60200	2.6	YRF	137 YR77	71M2-4	310
1.1	2720	1226	60500	2.9				
1.3	2440	1090	60700	3.3				
1.4	2130	951	60900	3.8				
0.67	4660	2067	27300	0.90				
0.82	3790	1693	31900	1.15				
0.89	3420	1550	33500	1.25	YR	107 YR77	71M2-4	195
0.98	3110	1407	34600	1.40	YRF	107 YR77	71M2-4	205
1.1	2670	1209	35900	1.60				
1.3	2330	1055	36400	1.85				
0.69	4450	1987	28600	0.95				
0.76	4030	1827	30800	1.05				
0.86	3490	1599	33200	1.25				
0.99	3090	1400	34600	1.40	YR	107 YR77	71M2-4	200
1.1	2670	1226	35900	1.60	YRF	107 YR77	71M2-4	210
1.5	2070	939	36700	2.1				
1.7	1790	822	37000	2.4				
1.1	2760	1207	22500	1.10	YR	97 YR57	71M2-4	130
1.3	2470	1084	24300	1.20	YRF	97 YR57	71M2-4	145
0.99	3180	1396	10800	0.95				
1.1	2780	1228	22500	1.10				
1.3	2480	1069	24200	1.20				
1.5	2160	938	25700	1.40				
1.7	1860	824	26900	1.60	YR	97 YR57	71M2-4	130
1.9	1670	737	27400	1.80	YRF	97 YR57	71M2-4	145
2.2	1430	632	27700	2.1				
3.2	980	431	28200	3.1				
3.6	860	379	28300	3.5				
4.1	765	336	28400	3.9				
1.7	1810	802	13800	0.85	YR	87 YR57	71M2-4	87
1.8	1700	754	15800	0.90	YRF	87 YR57	71M2-4	94



技术参数

Technical Data

P ₁ = 0.37 kW								
NA rpm	M ₂ Nm	i	Fr ₂ MAX[N]	f _s	Type	Gear unit	Motor size	 Kg
2.1	1450	649	17600	1.05	YR	87 YR57	71M2-4	87
					YRF	87 YR57	71M2-4	94
1.8	1780	776	15100	0.85	YR YRF	87 YR57 87 YR57	71M2-4 71M2-4	87 95
2.0	1570	685	16800	1.00				
2.3	1340	599	18300	1.15				
2.6	1170	525	19100	1.30				
3.0	1030	456	19700	1.50				
5.2	595	268	20000	2.6				
5.9	525	236	20000	2.9				
2.6	1260	538	18700	1.25	YR YRF	87 YR57 87 YR57	71M2-4 71M2-4	86 93
2.9	1100	472	19400	1.40				
3.5	930	400	20000	1.65				
3.8	830	361	20000	1.85				
3.7	860	373	9520	0.95	YR YRF	77 YR37 77 YR37	71M2-4 71M2-4	48 53
4.2	755	327	10500	1.10				
4.8	670	289	11100	1.20				
5.3	600	260	11600	1.35				
6.2	510	224	12000	1.60				
7.0	445	197	12300	1.85				
8.2	390	169	12500	2.1				
9.3	340	149	12700	2.4				
4.7	665	294	4670	0.90	YR YRF	67 YR37 67 YR37	71M2-4 71M2-4	42 45
5.3	600	261	7550	1.00				
5.9	540	234	8220	1.10				
6.9	460	200	8930	1.30				
2.7	1330	255.71	27900	2.3	YR YRF	97 97	90S-8 90S-8	115 130
2.8	1250	241.25	28000	2.4				
3.1	1120	216.28	28100	2.7				
3.6	970	186.30	28300	3.1				
3.1	1140	289.74	28100	2.6	YR YRF	97 97	80M1-6 80M1-6	105 125
3.5	1000	255.71	28200	3.0				
3.7	950	241.25	28300	3.2				
4.2	850	216.28	28400	3.5				
3.1	1130	216.54	19300	1.40	YR YRF	87 87	90S-8 90S-8	73 80
3.3	1070	205.71	19600	1.45				
3.7	940	181.77	20000	1.65				
3.6	970	246.54	20000	1.60	YR YRF	87 87	80M1-6 80M1-6	66 73
4.2	850	216.54	20000	1.80				
4.4	810	205.71	20000	1.90				
5.0	715	181.77	20000	2.2				
5.8	610	155.34	20000	2.5				
6.3	560	142.41	20000	2.8				



技术参数

Technical Data

P ₁ = 0.37 kW								
NA rpm	M ₂ Nm	i	Fr ₂ MAX[N]	f _s	Type	Gear unit	Motor size	 Kg
4.7	755	145.67	10500	1.10	YR	77	90S-8	47
4.9	720	138.39	10800	1.15	YRF	77	90S-8	53
5.6	630	121.42	11400	1.30				
5.4	655	166.59	11200	1.25	YR	77	80M1-6	40
6.2	570	145.67	11700	1.45	YRF	77	80M1-6	46
6.5	545	138.39	11900	1.50				
7.1	500	195.24	12100	1.65				
8.3	425	166.59	12400	1.90				
9.5	375	145.67	12600	2.2	YR	77	71M2-4	38
10	355	138.39	12600	2.3	YRF	77	71M2-4	44
11	310	121.42	12800	2.6				
13	265	102.99	12900	3.1				
15	240	92.97	12900	3.5				
5.7	620	158.14	7300	0.95	YR	67	80M1-6	34
6.5	540	137.67	8210	1.10	YRF	67	80M1-6	37
7.0	505	128.97	8530	1.20				
7.9	445	113.94	9010	1.35				
6.9	510	199.81	8480	1.15				
7.5	470	184.07	8820	1.25				
8.7	405	158.14	9310	1.50				
10	355	137.67	9620	1.70				
11	330	128.97	9740	1.80				
12	290	113.94	9920	2.1	YR	67	71M2-4	32
13	270	105.83	10000	2.2	YRF	67	71M2-4	35
14	245	95.91	10100	2.4				
16	220	86.11	10200	2.7				
19	190	74.17	10300	3.2				
20	179	69.75	10300	3.4				
23	157	61.26	10400	3.8				
24	146	56.89	10400	4.1				
7.0	505	128.77	6510	0.90	YR	57	80M1-6	27
7.5	475	120.63	7000	0.95	YRF	57	80M1-6	31
8.4	420	106.58	7240	1.10				
9.1	390	98.99	7350	1.15				
7.4	480	186.89	6980	0.95				
8.0	440	172.17	7140	1.00				
9.3	380	147.92	7390	1.20				
11	330	128.77	7550	1.35	YR	57	71M2-4	25
11	310	120.63	7610	1.45	YRF	57	71M2-4	29
13	275	106.58	7700	1.65				
14	255	98.99	7750	1.80				
15	230	89.71	7800	1.95				
17	205	80.55	7840	2.2				



技术参数

Technical Data

P ₁ = 0.37 kW								
NA rpm	M ₂ Nm	i	Fr ₂ MAX[N]	f _s	Type	Gear unit	Motor size	 Kg
20	177	69.23	7890	2.5				
21	166	64.85	7910	2.7	YR	57	71M2-4	25
24	147	57.29	7760	3.1	YRF	57	71M2-4	29
26	136	53.22	7600	3.3				
29	124	48.23	7380	3.6				
9.9	360	139.99	3490	0.85				
11	310	121.87	5350	0.95				
12	290	114.17	5460	1.05				
14	260	100.86	5630	1.15				
15	240	93.68	5700	1.25				
16	215	84.90	5790	1.40				
18	195	76.23	5870	1.55	YR	47	71M2-4	20
20	176	68.54	5930	1.70	YRF	47	71M2-4	20
21	164	64.21	5960	1.80				
24	145	56.73	6010	2.1				
26	135	52.69	5990	2.2				
29	122	47.75	5820	2.5				
32	110	42.87	5650	2.7				
37	95	36.93	5410	3.2				
40	89	34.73	5310	3.4				
41	87	33.79	5270	2.8				
44	80	31.12	5150	2.8	YR	47	71M2-4	20
52	69	26.74	4920	4.4	YRF	47	71M2-4	20
59	60	23.28	4720	5.0				
63	56	21.81	4620	5.4				
15	230	90.77	4250	0.85	YR	37	71M2-4	16
16	215	84.61	4720	0.90	YRF	37	71M2-4	17
19	189	73.96	5070	1.05				
20	178	69.33	5210	1.15				
23	157	61.18	5410	1.30				
25	143	55.76	5530	1.40				
29	123	48.08	5590	1.60				
31	115	44.81	5480	1.75	YR	37	71M2-4	16
35	100	39.17	5290	2.0	YRF	37	71M2-4	17
38	94	36.72	5190	2.1				
43	83	32.40	5010	2.4				
48	74	28.73	4850	2.7				
57	63	24.42	4620	3.2				
49	73	28.32	4830	2.8				
53	67	26.03	4710	2.8	YR	37	71M2-4	16
62	57	22.27	4500	3.5	YRF	37	71M2-4	17
71	49	19.31	4320	4.1				
76	46	18.05	4230	4.3				



技术参数

Technical Data

P ₁ = 0.37 kW								
NA rpm	M ₂ Nm	i	Fr ₂ MAX[N]	f _s	Type	Gear unit	Motor size	 Kg
88	40	15.60	4050	5.0	YR	37	71M2-4	16
104	34	13.25	3850	5.6	YRF	37	71M2-4	17
117	30	11.83	3720	6.0				
23	157	61.30	3870	0.85				
25	143	55.87	3800	0.90				
29	123	48.17	3680	1.05				
31	115	44.90	3620	1.15	YR	27	71M2-4	9.9
35	101	39.25	3510	1.30	YRF	27	71M2-4	9.8
38	94	36.79	3460	1.40				
43	83	32.47	3350	1.55				
48	74	28.78	3250	1.75				
56	63	24.47	3110	2.1				
49	73	28.37	3240	1.80				
53	67	26.09	3170	1.95				
62	57	22.32	3040	2.3	YR	27	71M2-4	9.6
71	50	19.35	2920	2.6	YRF	27	71M2-4	9.6
76	46	18.08	2860	2.8				
88	40	15.63	2750	3.3				
104	34	13.28	2620	3.8				
36	99	38.61	770	0.85				
38	93	36.20	1260	0.90	YR	17	71M2-4	9.2
43	82	31.94	1910	1.05	YRF	17	71M2-4	9.1
49	73	28.32	1880	1.15				
57	62	24.07	1830	1.40				
55	65	25.23	1840	1.30				
60	59	23.15	1820	1.45				
70	51	19.71	1760	1.70				
81	44	16.99	1710	1.95				
87	41	15.84	1680	2.1				
100	35	13.84	1630	2.4				
106	33	12.98	1610	2.6				
121	29	11.45	1560	2.8	YR	17	71M2-4	8.9
136	26	10.15	1520	3.0	YRF	17	71M2-4	8.8
160	22	8.63	1460	3.3				
183	19	7.55	1370	2.9				
196	18	7.04	1350	3.1				
224	16	6.15	1300	3.4				
239	15	5.76	1280	3.6				
271	13	5.09	1240	3.9				
306	12	4.51	1200	4.2				
360	9.8	3.83	1150	4.6				
174	20	5.18	4570	3.7	YRX	67	80M1-6	21
199	18	4.53	4380	4.6	YRXF	67	80M1-6	25
209	17	4.30	4310	4.7				



技术参数

Technical Data

P ₁ = 0.37 kW								
N _A rpm	M ₂ Nm	i	Fr ₂ MAX[N]	f _s	Type	Gear unit	Motor size	 Kg
239	15	3.77	4130	5.9	YRX YRXF	67 67	80M1-6 80M1-6	21 25
227	16	6.07	4200	2.8				
267	13	5.18	3990	5.6				
305	12	4.53	3820	7.1				
321	11	4.30	3760	7.3				
366	9.7	3.77	3610	9.0	YRX	67	71M2-4	19
431	8.2	3.20	3420	12	YRXF	67	71M2-4	23
478	7.4	2.89	3310	14				
543	6.5	2.54	3170	18				
575	6.1	2.40	3110	20				
675	5.2	2.04	2950	26				
207	17	4.35	3500	4.0	YRX	57	80M1-6	18
238	15	3.79	3350	4.6	YRXF	57	80M1-6	20
254	14	3.55	3280	5.0				
251	14	5.50	3300	2.8				
272	13	5.07	3210	2.8				
317	11	4.35	3060	6.1				
364	9.7	3.79	2930	7.1				
389	9.1	3.55	2870	7.6	YRX	57	71M2-4	16
440	8.0	3.14	2760	8.1	YRXF	57	71M2-4	18
474	7.5	2.91	2690	8.9				
523	6.8	2.64	2610	10				
582	6.1	2.37	2520	11				
676	5.2	2.04	2400	13				
719	4.9	1.92	2350	14				
P ₁ = 0.55 kW								
0.22	19800	6077	120000	0.90				
0.25	17600	5407	120000	1.00	YR	167 YR97	80M1-4	750
0.29	15000	4650	120000	1.20	YRF	167 YR97	80M1-4	760
0.33	13100	4129	120000	1.35				
0.28	16900	4926	22000	0.75				
0.31	14700	4325	53900	0.90	YR	147 YR77	80M1-4	425
0.36	12900	3754	62900	1.00	YRF	147 YR77	80M1-4	430
0.41	11200	3302	65900	1.15				
0.47	9830	2898	68000	1.30				
0.53	8890	2555	69300	1.45				
0.62	7700	2211	70600	1.70				
0.70	6790	1951	71500	1.90	YR	147 YR77	80M1-4	420
0.80	5810	1705	72400	2.2	YRF	147 YR77	80M1-4	430
0.89	5210	1536	72800	2.5				
1.0	4510	1329	73300	2.9				



技术参数

Technical Data

P ₁ = 0.55 kW								
Na rpm	M ₂ Nm	i	Fr ₂ MAX[N]	f _s	Type	Gear unit	Motor size	 Kg
1.2	3920	1166	73600	3.3	YR	147 YR77	80M1-4	420
					YRF	147 YR77	80M1-4	430
0.55	8650	2484	51200	0.90	YR YRF	137 YR77 137 YR77	80M1-4 80M1-4	290 315
0.51	9250	2658	48400	0.85				
0.56	8400	2412	52300	0.95				
0.66	7220	2073	55000	1.10				
0.74	6320	1839	56500	1.25				
0.85	5420	1598	57900	1.50				
0.97	4840	1397	58600	1.65				
1.1	4220	1226	59300	1.90				
1.2	3780	1090	59700	2.1				
1.4	3300	951	60100	2.4				
1.6	2820	831	60500	2.8				
0.97	4830	1407	21900	0.90				
1.1	4150	1209	30200	1.05				
1.3	3620	1055	32700	1.20				
1.5	3170	919	34400	1.35				
1.7	2830	815	35500	1.50				
1.9	2470	717	36200	1.75				
2.2	2160	626	36600	2.0				
0.97	4810	1400	22800	0.90	YR YRF	107 YR77 107 YR77	80M1-4 80M1-4	205 210
1.1	4180	1226	30100	1.05				
1.2	3740	1104	32200	1.15				
1.4	3220	939	34200	1.35				
1.7	2800	822	35600	1.55				
1.7	2870	824	21800	1.05	YR YRF	97 YR57 97 YR57	80M1-4 80M1-4	130 150
1.8	2570	737	23700	1.15				
2.1	2200	632	25500	1.35				
2.4	1920	560	26700	1.55				
2.8	1670	484	27400	1.80				
3.1	1510	431	27600	2.0				
3.6	1320	379	27900	2.3				
4.0	1180	336	28000	2.6				
4.6	1030	296	28200	2.9				
5.5	860	249	28300	3.5				
2.6	1820	525	13600	0.85				
3.0	1580	456	16700	1.00				
3.4	1370	398	18100	1.15				
3.9	1210	352	18900	1.30				
4.5	1040	305	19700	1.50				
2.9	1690	472	15900	0.90	YR YRF	87 YR57 87 YR57	80M1-4 80M1-4	88 95
3.4	1420	400	17800	1.10				
3.8	1280	361	18600	1.20				



技术参数

Technical Data

P ₁ = 0.55 kW								
NA rpm	M ₂ Nm	i	Fr ₂ MAX[N]	f _s	Type	Gear unit	Motor size	 Kg
4.9	990	276	4510	0.85				
5.8	840	236	9730	1.00	YR	77 YR37	80M1-4	49
6.2	785	221	10200	1.05	YRF	77 YR37	80M1-4	54
7.3	660	186	11200	1.25				
2.7	1980	255.71	26500	1.50	YR	97	80M1-4	115
2.8	1860	241.25	26900	1.60	YRF	97	80M1-4	130
3.1	1670	216.28	27400	1.80				
3.1	1690	289.74	27400	1.75				
3.5	1490	255.71	27700	2.0	YR	97	80M2-6	110
3.7	1410	241.25	27800	2.1	YRF	97	80M2-6	125
4.2	1260	216.28	28000	2.4				
4.7	1120	289.74	28100	2.7				
5.3	990	255.71	28200	3.0	YR	97	80M1-4	105
5.6	930	241.25	28300	3.2	YRF	97	80M1-4	125
6.3	840	216.28	28400	3.6				
3.6	1440	246.54	17700	1.10				
4.2	1260	216.54	18700	1.25	YR	87	80M1-4	68
4.4	1200	205.71	19000	1.30	YRF	87	80M1-4	75
5.0	1060	181.77	19600	1.45				
5.8	910	155.34	20000	1.70				
5.5	950	246.54	20000	1.65				
6.3	840	216.54	20000	1.85				
6.6	795	205.71	20000	1.95				
7.5	700	181.77	20000	2.2	YR	87	80M1-4	66
8.8	600	155.34	20000	2.6	YRF	87	80M1-4	73
9.6	550	142.41	20000	2.8				
11	485	124.97	20000	3.2				
11	455	118.43	20000	3.4				
13	400	103.65	20000	3.9				
8.2	645	166.59	11300	1.25				
9.3	565	145.67	11800	1.45				
9.8	535	138.39	11900	1.55				
11	470	121.42	12200	1.75	YR	77	80M1-4	40
13	400	102.99	12500	2.1	YRF	77	80M1-4	46
15	360	92.97	12600	2.3				
17	315	81.80	12800	2.6				
18	300	77.24	12800	2.8				
21	255	65.77	12900	3.2				
8.6	610	158.14	7430	1.00				
9.9	530	137.67	8290	1.15	YR	67	80M1-4	34
11	500	128.97	8600	1.20	YRF	67	80M1-4	37
12	440	113.94	9060	1.35				
13	410	105.83	9280	1.45				



技术参数

Technical Data

P ₁ = 0.55 kW								
NA rpm	M ₂ Nm	i	Fr ₂ MAX[N]	f _s	Type	Gear unit	Motor size	 Kg
14	370	95.91	9520	1.60				
16	335	86.11	9730	1.80				
18	285	74.17	9940	2.1	YR	67	80M1-4	34
20	270	69.75	10000	2.2	YRF	67	80M1-4	37
22	235	61.26	10100	2.5				
24	220	56.89	10200	2.7				
11	465	120.63	7030	0.95				
13	410	106.58	7260	1.10				
14	380	98.99	7370	1.20				
15	345	89.71	7490	1.30				
17	310	80.55	7600	1.45				
20	265	69.23	7710	1.70	YR	57	80M1-4	27
21	250	64.85	7750	1.80	YRF	57	80M1-4	31
24	220	57.29	7530	2.0				
26	205	53.22	7390	2.2				
28	186	48.23	7190	2.4				
31	167	43.30	6980	2.7				
36	144	37.30	6700	3.1				
39	136	35.07	6580	3.3				
52	102	26.31	6060	4.4	YR	57	80M1-4	27
54	97	24.99	5970	4.7	YRF	57	80M1-4	30
62	85	21.93	5740	5.3				
73	72	18.60	5460	6.3				
15	360	93.68	3280	0.85				
16	330	84.90	5230	0.90				
18	295	76.23	5450	1.00				
20	265	68.54	5600	1.15				
21	250	64.21	5670	1.20				
24	220	56.73	5790	1.35	YR	47	80M1-4	22
26	205	52.69	5770	1.45	YRF	47	80M1-4	22
28	184	47.75	5630	1.65				
32	166	42.87	5470	1.80				
37	143	36.93	5260	2.1				
39	134	34.73	5180	2.2				
46	115	29.88	4970	2.6				
51	103	26.74	4820	2.9	YR	47	80M1-4	22
58	90	23.28	4630	3.3	YRF	47	80M1-4	22
62	84	21.81	4550	3.6				
22	235	61.18	3910	0.85				
24	215	55.76	4740	0.95				
28	186	48.08	5120	1.10	YR	37	80M1-4	18
30	173	44.81	5230	1.15	YRF	37	80M1-4	19
35	151	39.17	5070	1.30				
37	142	36.72	4990	1.40				



技术参数

Technical Data

P ₁ = 0.55 kW								
NA rpm	M ₂ Nm	i	Fr ₂ MAX[N]	f _s	Type	Gear unit	Motor size	 Kg
42	125	32.40	4840	1.60	YR	37	80M1-4	18
47	111	28.73	4700	1.80	YRF	37	80M1-4	19
56	94	24.42	4500	2.1				
61	86	22.27	4390	2.3				
70	75	19.31	4220	2.7				
75	70	18.05	4140	2.9	YR	37	80M1-4	18
87	60	15.60	3970	3.3	YRF	37	80M1-4	19
103	51	13.25	3790	3.7				
115	46	11.83	3670	4.0				
35	152	39.25	3280	0.85				
37	142	36.79	3240	0.90	YR	27	80M1-4	12
42	125	32.47	3160	1.05	YRF	27	80M1-4	12
47	111	28.78	3080	1.15				
56	95	24.47	2970	1.40				
61	86	22.32	2910	1.50				
70	75	19.35	2810	1.75				
75	70	18.08	2760	1.85				
87	60	15.63	2660	2.2				
102	51	13.28	2550	2.5				
115	46	11.86	2470	2.8				
134	39	10.13	2370	3.1				
145	36	9.41	2290	3.4	YR	27	80M1-4	12
167	32	8.16	2200	3.7	YRF	27	80M1-4	12
178	29	7.63	2160	3.8				
206	26	6.59	2070	4.2				
243	22	5.60	1980	4.6				
272	19	5.00	1910	4.9				
318	17	4.27	1830	5.3				
340	15	4.00	1790	5.5				
404	13	3.37	1700	6.1				
50	105	53.76	235	0.80				
57	92	47.44	1280	0.90	YR	17	71M2-2	9.2
61	86	44.18	1610	1.00	YRF	17	71M2-2	9.1
70	75	38.61	1590	1.15				
69	76	19.71	1590	1.10				
80	66	16.99	1560	1.30				
86	61	15.84	1550	1.40				
98	54	13.84	1510	1.60				
105	50	12.98	1500	1.70	YR	17	80M1-4	11
119	44	11.45	1460	1.85	YRF	17	80M1-4	11
134	39	10.15	1430	1.95				
158	33	8.63	1380	2.2				
180	29	7.55	1290	1.90				
193	27	7.04	1270	2.0				



技术参数

Technical Data

P ₁ = 0.55 kW								
NA rpm	M ₂ Nm	i	Fr ₂ MAX[N]	f _s	Type	Gear unit	Motor size	 Kg
221	24	6.15	1240	2.3				
236	22	5.76	1220	2.4	YR	17	80M1-4	11
267	20	5.09	1190	2.6	YRF	17	80M1-4	11
302	17	4.51	1150	2.8				
355	15	3.83	1110	3.0				
313	17	8.63	1170	4.3				
358	15	7.55	1100	3.8	YR	17	71M2-2	8.9
384	14	7.04	1080	4.0	YRF	17	71M2-2	8.8
439	12	6.15	1050	4.5				
174	30	5.18	4510	2.5				
199	26	4.53	4320	3.1	YRX	67	80M1-4	22
209	25	4.30	4260	3.2	YRXF	67	80M1-4	26
239	22	3.77	4090	4.0				
263	20	5.18	3970	3.8				
300	18	4.53	3800	4.7				
316	17	4.30	3740	4.8				
360	15	3.77	3590	6.0				
425	12	3.20	3410	8.1				
471	11	2.89	3300	9.5	YRX	67	80M1-4	21
535	9.8	2.54	3170	12	YRXF	67	80M1-4	25
567	9.3	2.40	3110	13				
666	7.9	2.04	2950	17				
732	7.2	1.86	2860	18				
845	6.2	1.61	2730	18				
207	25	4.35	3440	2.7				
238	22	3.79	3300	3.1	YRX	57	80M2-6	19
254	21	3.55	3230	3.3	YRXF	57	80M2-6	21
287	18	3.14	3110	3.6				
309	17	2.91	3040	3.9				
312	17	4.35	3040	4.1				
359	15	3.79	2910	4.7				
383	14	3.55	2850	5.0				
434	12	3.14	2740	5.4				
467	11	2.91	2680	6.0				
515	10	2.64	2600	6.8	YRX	57	80M1-4	18
574	9.2	2.37	2510	7.5	YRXF	57	80M1-4	20
666	7.9	2.04	2390	8.7				
708	7.4	1.92	2350	9.3				
823	6.4	1.65	2230	11				
921	5.7	1.48	2150	12				
1045	5.0	1.30	2070	13				



技术参数

Technical Data

P ₁ = 0.75 kW								
NA rpm	M ₂ Nm	i	Fr ₂ MAX[N]	f _s	Type	Gear unit	Motor size	 Kg
0.30	20700	4650	120000	0.85	YR	167 YR97	80M2-4	750
0.33	18200	4129	120000	1.00	YRF	167 YR97	80M2-4	760
0.52	12100	2657	120000	1.50				
0.59	10500	2333	120000	1.70	YR	167 YR97	80M2-4	750
0.66	9300	2085	120000	1.95	YRF	167 YR97	80M2-4	760
0.96	6550	1438	120000	2.8				
0.42	15300	3302	46300	0.85	YR	147 YR77	80M2-4	425
0.48	13400	2898	61800	0.95	YRF	147 YR77	80M2-4	435
0.54	12100	2555	64400	1.10				
0.62	10500	2211	67100	1.25				
0.71	9230	1951	68800	1.40	YR	147 YR77	80M2-4	425
0.81	7940	1705	70400	1.65	YRF	147 YR77	80M2-4	435
0.90	7130	1536	71200	1.80				
1.0	6170	1329	72100	2.1				
1.2	5380	1166	72700	2.4				
0.74	8730	1863	50900	0.90				
0.87	7390	1586	54600	1.10	YR	137 YR77	80M2-4	285
0.99	6580	1391	56100	1.20	YRF	137 YR77	80M2-4	305
1.1	5920	1256	57100	1.35				
0.67	9810	2073	37900	0.80				
0.75	8610	1839	51400	0.95				
0.86	7410	1598	54600	1.10				
0.99	6590	1397	56100	1.20	YR	137 YR77	80M2-4	295
1.1	5750	1226	57400	1.40	YRF	137 YR77	80M2-4	315
1.3	5140	1090	58200	1.55				
1.4	4490	951	59000	1.80				
1.7	3860	831	59600	2.1				
1.9	3360	730	60100	2.4				
1.3	4940	1055	16400	0.85	YR	107 YR77	80M2-4	200
1.5	4310	919	29400	1.00	YRF	107 YR77	80M2-4	205
1.7	3840	815	31700	1.10				
1.5	4400	939	28900	1.00				
1.7	3830	822	31800	1.10	YR	107 YR77	80M2-4	205
3.7	1710	369	37100	2.5	YRF	107 YR77	80M2-4	210
4.3	1490	323	37200	2.9				
2.2	2990	632	20100	1.00				
2.5	2620	560	23400	1.15				
2.9	2270	484	25200	1.30				
3.2	2050	431	26200	1.45	YR	97 YR57	80M2-4	135
3.6	1800	379	27100	1.65	YRF	97 YR57	80M2-4	150
4.1	1600	336	27500	1.90				
4.7	1400	296	27800	2.1				
5.5	1170	249	28100	2.6				



技术参数

Technical Data

P ₁ = 0.75 kW								
NA rpm	M ₂ Nm	i	Fr ₂ MAX[N]	f _s	Type	Gear unit	Motor size	 Kg
3.5	1870	398	9720	0.85				
3.9	1650	352	16200	0.95	YR	87 YR57	80M2-4	90
4.5	1430	305	17700	1.10	YRF	87 YR57	80M2-4	98
5.2	1260	268	18700	1.25				
5.9	1110	236	19400	1.40				
3.8	1740	361	15500	0.90	YR	87 YR57	80M2-4	89
4.6	1440	300	17700	1.10	YRF	87 YR57	80M2-4	96
5.4	1220	256	18900	1.25				
2.8	2610	251.15	36000	1.65	YR	107	80M2-4	180
3.0	2390	229.95	36300	1.80	YRF	107	80M2-4	185
3.4	2110	203.16	36700	2.0				
3.2	2240	216.28	25300	1.35	YR	97	100L1-8	125
3.7	1930	186.30	26600	1.55	YRF	97	100L1-8	140
4.1	1760	170.02	27200	1.70				
3.5	2030	255.71	26200	1.45	YR	97	90S-6	115
3.7	1920	241.25	26700	1.55	YRF	97	90S-6	130
4.2	1720	216.28	27300	1.75				
4.8	1500	289.74	27600	2.0				
5.4	1330	255.71	27900	2.3				
5.7	1250	241.25	28000	2.4	YR	97	80M2-4	110
6.4	1120	216.28	28100	2.7	YRF	97	80M2-4	125
7.4	970	186.30	28300	3.1				
8.1	880	170.02	28300	3.4				
4.2	1720	216.54	15600	0.90	YR	87	90S-6	73
4.4	1640	205.71	16300	0.95	YRF	87	90S-6	80
5.0	1450	181.77	17600	1.05				
5.8	1240	155.34	18800	1.25	YR	87	90S-6	73
6.3	1130	142.41	19300	1.35	YRF	87	90S-6	80
5.6	1280	246.54	18600	1.20				
6.4	1120	216.54	19300	1.40				
6.7	1070	205.71	19600	1.45				
7.6	940	181.77	20000	1.65				
8.9	810	155.34	20000	1.90	YR	87	80M2-4	68
9.7	740	142.41	20000	2.1	YRF	87	80M2-4	75
11	650	124.97	20000	2.4				
12	615	118.43	20000	2.5				
13	540	103.65	20000	2.9				
15	485	93.38	20000	3.2				
8.3	860	166.59	9490	0.95	YR	77	80M2-4	42
9.5	755	145.67	10500	1.10	YRF	77	80M2-4	48
10	720	138.39	10800	1.15				



技术参数

Technical Data

P ₁ = 0.75 kW								
NA rpm	M ₂ Nm	i	Fr ₂ MAX[N]	f _s	Type	Gear unit	Motor size	 Kg
11	630	121.42	11400	1.30				
13	535	102.99	11900	1.55				
15	485	92.97	12200	1.70				
17	425	81.80	12400	1.95				
18	400	77.24	12500	2.1	YR	77	80M2-4	42
21	340	65.77	12700	2.4	YRF	77	80M2-4	48
24	300	57.68	12800	2.7				
27	270	52.07	12900	3.0				
30	240	45.81	12900	3.5				
32	225	43.26	13000	3.7				
11	670	128.97	4040	0.90				
12	590	113.94	7660	1.00				
13	550	105.83	8120	1.10				
14	500	95.91	8600	1.20				
16	445	86.11	9010	1.35	YR	67	80M2-4	35
19	385	74.17	9430	1.55	YRF	67	80M2-4	38
20	360	69.75	9570	1.65				
23	320	61.26	9800	1.90				
24	295	56.89	9910	2.0				
27	270	51.56	10000	2.2				
30	240	46.29	10100	2.5				
13	555	106.58	4610	0.80				
14	515	98.99	6200	0.90				
15	465	89.71	7040	0.95	YR	57	80M2-4	28
17	420	80.55	7240	1.10	YRF	57	80M2-4	32
20	360	69.23	7450	1.25				
21	335	64.85	7430	1.35				
24	295	57.29	7220	1.50				
26	275	53.22	7090	1.65				
29	250	48.23	6930	1.80				
32	225	43.30	6740	2.0	YR	57	80M2-4	28
37	194	37.30	6490	2.3	YRF	57	80M2-4	32
39	182	35.07	6380	2.5				
46	157	30.18	6130	2.9				
51	140	26.97	5940	3.2				
52	137	26.31	5900	3.3				
55	130	24.99	5820	3.5	YR	57	80M2-4	28
63	114	21.93	5610	4.0	YRF	57	80M2-4	31
74	97	18.60	5350	4.7				
20	355	68.54	3660	0.85				
21	335	64.21	4950	0.90	YR	47	80M2-4	23
24	295	56.73	5450	1.00	YRF	47	80M2-4	23
26	275	52.69	5480	1.10				
29	250	47.75	5370	1.20				



技术参数

Technical Data

P ₁ = 0.75 kW								
NA rpm	M ₂ Nm	i	Fr ₂ MAX[N]	f _s	Type	Gear unit	Motor size	 Kg
32	225	42.87	5240	1.35				
37	192	36.93	5060	1.55				
40	180	34.73	4980	1.65	YR	47	80M2-4	23
46	155	29.88	4800	1.95	YRF	47	80M2-4	23
52	139	26.70	4660	2.2				
58	122	23.59	4510	2.5				
52	139	26.74	4660	2.2				
59	121	23.28	4490	2.5				
63	113	21.81	4420	2.7	YR	47	80M2-4	23
72	100	19.27	4270	3.0	YRF	47	80M2-4	23
77	93	17.89	4180	3.1				
85	84	16.22	4070	3.3				
29	250	48.08	2330	0.80	YR	37	80M2-4	19
31	235	44.81	4230	0.85	YRF	37	80M2-4	20
35	205	39.17	4720	1.00				
38	191	36.72	4740	1.05				
43	168	32.40	4610	1.20	YR	37	80M2-4	19
48	149	28.73	4490	1.35	YRF	37	80M2-4	20
57	127	24.42	4320	1.60				
62	116	22.27	4230	1.75				
71	100	19.31	4080	2.0				
76	94	18.05	4010	2.1				
88	81	15.60	3850	2.5	YR	37	80M2-4	19
104	69	13.25	3690	2.8	YRF	37	80M2-4	20
117	61	11.83	3570	3.0				
137	53	10.11	3420	3.2				
146	49	9.47	3360	3.4				
48	149	28.78	2880	0.85	YR	27	80M2-4	13
56	127	24.47	2800	1.00	YRF	27	80M2-4	13
62	116	22.32	2750	1.10				
71	100	19.35	2670	1.30				
76	94	18.08	2630	1.40				
88	81	15.63	2550	1.60				
104	69	13.28	2450	1.90				
116	62	11.86	2380	2.1	YR	27	80M2-4	13
136	53	10.13	2290	2.3	YRF	27	80M2-4	13
147	49	9.41	2210	2.5				
169	42	8.16	2130	2.7				
181	40	7.63	2090	2.8				
209	34	6.59	2010	3.1				
246	29	5.60	1930	3.4				
276	26	5.00	1870	3.7				



技术参数

Technical Data

P ₁ = 0.75 kW								
NA rpm	M ₂ Nm	i	Fr ₂ MAX[N]	f _s	Type	Gear unit	Motor size	 Kg
70	102	19.71	465	0.85				
81	88	16.99	1390	0.95				
87	82	15.84	1380	1.05				
100	72	13.84	1370	1.20				
106	67	12.98	1360	1.25				
121	59	11.45	1350	1.35				
136	53	10.15	1320	1.45				
160	45	8.63	1290	1.60	YR	17	80M2-4	12
183	39	7.55	1200	1.45	YRF	17	80M2-4	12
196	37	7.04	1180	1.50				
224	32	6.15	1160	1.70				
239	30	5.76	1150	1.75				
271	26	5.09	1120	1.95				
306	23	4.51	1090	2.1				
360	20	3.83	1060	2.3				
236	30	11.45	1200	2.7				
266	27	10.15	1170	2.9				
313	23	8.63	1130	3.1				
358	20	7.55	1060	2.8				
384	19	7.04	1040	2.9	YR	17	80M1-2	11
439	16	6.15	1010	3.3	YRF	17	80M1-2	11
468	15	5.76	990	3.5				
531	14	5.09	960	3.8				
599	12	4.51	930	4.0				
704	10	3.83	890	4.4				
199	36	4.53	4260	2.3				
209	34	4.30	4200	2.3	YRX	67	90S-6	27
239	30	3.77	4040	2.9	YRXF	67	90S-6	31
281	26	3.20	3840	3.9				
267	27	5.18	3900	2.8				
305	24	4.53	3750	3.5				
321	22	4.30	3690	3.6				
366	20	3.77	3540	4.4				
431	17	3.20	3360	6.0				
478	15	2.89	3260	7.1	YRX	67	80M2-4	22
543	13	2.54	3130	8.9	YRXF	67	80M2-4	26
575	13	2.40	3070	9.8				
675	11	2.04	2920	13				
743	9.6	1.86	2830	13				
858	8.3	1.61	2700	14				
238	30	3.79	3240	2.3				
254	28	3.55	3180	2.4	YRX	57	80M2-4	24
287	25	3.14	3060	2.6	YRXF	57	80M2-4	26
309	23	2.91	3000	2.9				
341	21	2.64	2910	3.3				



技术参数

Technical Data

P₁ = 0.75 kW								
--------------------------------	--	--	--	--	--	--	--	--

N _A rpm	M ₂ Nm	i	Fr ₂ MAX[N]	f _s	Type	Gear unit	Motor size	Kg
317	23	4.35	2980	3.0				
364	20	3.79	2860	3.5				
389	18	3.55	2800	3.8				
440	16	3.14	2700	4.0				
474	15	2.91	2630	4.4				
523	14	2.64	2560	5.0	YRX	57	80M2-4	19
582	12	2.37	2470	5.6	YRXF	57	80M2-4	21
676	11	2.04	2360	6.5				
719	10	1.92	2310	6.9				
835	8.6	1.65	2210	8.0				
935	7.7	1.48	2130	8.8				
1060	6.8	1.30	2050	9.3				

P₁ = 1.1 kW								
-------------------------------	--	--	--	--	--	--	--	--

0.53	17900	2657	120000	1.00				
0.60	15600	2333	120000	1.15				
0.67	13800	2085	120000	1.30				
0.75	12300	1877	120000	1.45	YR	167 YR97	90S-4	760
0.84	11000	1670	120000	1.65	YRF	167 YR97	90S-4	760
0.97	9680	1438	120000	1.85				
1.1	8620	1279	120000	2.1				
1.2	7510	1123	120000	2.4				
<hr/>								
0.63	15300	2211	46800	0.85				
0.72	13500	1951	61700	0.95				
0.82	11700	1705	65200	1.10				
0.91	10500	1536	67100	1.25				
1.1	9060	1329	69000	1.45	YR	147 YR77	90S-4	430
1.2	7920	1166	70400	1.65	YRF	147 YR77	90S-4	440
1.4	6960	1029	71400	1.85				
1.6	6030	889	72200	2.2				
1.8	5300	784	72700	2.5				
2.0	4680	695	73200	2.8				
<hr/>								
1.0	9610	1391	41900	0.85				
1.1	8660	1256	51200	0.90				
1.3	7590	1105	54200	1.05	YR	137 YR77	90S-4	290
1.3	7160	1043	55100	1.10	YRF	137 YR77	90S-4	310
1.6	6070	888	56900	1.30				
<hr/>								
1.0	9630	1397	41500	0.85				
1.1	8420	1226	52200	0.95				
1.3	7510	1090	54400	1.05				
1.5	6560	951	56100	1.20	YR	137 YR77	90S-4	300
1.7	5670	831	57500	1.40	YRF	137 YR77	90S-4	320
1.9	4950	730	58500	1.60				
2.2	4230	629	59300	1.90				



技术参数

Technical Data

P ₁ = 1.1 kW								
NA rpm	M ₂ Nm	i	Fr ₂ MAX[N]	f _s	Type	Gear unit	Motor size	 Kg
2.5	3830	560	59700	2.1	YR	137 YR77	90S-4	300
2.9	3300	490	60100	2.4	YRF	137 YR77	90S-4	320
1.9	4930	717	17300	0.85				
2.3	4150	614	30200	1.05				
2.6	3670	544	32500	1.15				
2.8	3310	492	33900	1.30	YR	107 YR77	90S-4	205
3.4	2810	417	35500	1.55	YRF	107 YR77	90S-4	210
3.8	2510	369	36200	1.70				
4.3	2200	323	36600	1.95				
4.9	1930	285	36800	2.2				
5.5	1700	253	37100	2.5				
3.2	2990	431	20300	1.00				
3.7	2620	379	23400	1.15				
4.2	2330	336	24900	1.30	YR	97 YR57	90S-4	140
4.7	2050	296	26200	1.45	YRF	97 YR57	90S-4	155
5.6	1710	249	27300	1.75				
6.0	1590	234	27500	1.90				
6.7	1430	209	27700	2.1				
5.2	1840	268	11700	0.85	YR	87 YR57	90S-4	95
5.9	1630	236	16400	0.95	YRF	87 YR57	90S-4	105
6.7	1430	209	17700	1.10				
5.5	1780	256	15100	0.85	YR	87 YR57	90S-4	94
6.0	1610	232	16500	0.95	YRF	87 YR57	90S-4	100
7.2	1370	195	18100	1.15				
2.7	3940	251.15	31300	1.10	YR	107	100L2-8	185
2.9	3610	229.95	32700	1.20	YRF	107	100L2-8	190
3.3	3190	203.16	34300	1.35				
3.9	2700	172.34	35800	1.60				
3.6	2920	255.71	21500	1.05	YR	97	90L-6	115
3.8	2750	241.25	22600	1.10	YRF	97	90L-6	130
4.2	2470	216.28	24200	1.20				
4.9	2130	186.30	25900	1.40				
5.5	1920	255.71	26700	1.55	YR	97	90S-4	115
5.8	1810	241.25	27100	1.65	YRF	97	90S-4	130
6.5	1620	216.28	27500	1.85				
7.5	1400	186.30	27800	2.2				
8.2	1280	170.02	27900	2.4				
9.3	1130	150.78	28100	2.7				
11	950	126.75	28300	3.2				
12	870	116.48	28300	3.4				
6.5	1620	216.54	16400	0.95	YR	87	90S-4	73
6.8	1540	205.71	17000	1.00	YRF	87	90S-4	80
7.7	1360	181.77	18100	1.15				



技术参数

Technical Data

P ₁ = 1.1 kW								
NA rpm	M ₂ Nm	i	Fr ₂ MAX[N]	f _s	Type	Gear unit	Motor size	 Kg
9.0	1170	155.34	19100	1.35				
9.8	1070	142.41	19600	1.45				
11	940	124.97	20000	1.65				
12	890	118.43	20000	1.75				
14	780	103.65	20000	2.0				
15	700	93.38	20000	2.2	YR	87	90S-4	73
17	615	81.92	20000	2.5	YRF	87	90S-4	80
19	545	72.57	20000	2.9				
22	480	63.68	20000	3.2				
23	455	60.35	20000	3.4				
27	395	52.82	20000	3.9				
12	910	121.42	8990	0.90	YR	77	90S-4	47
14	775	102.99	10300	1.05	YRF	77	90S-4	53
15	700	92.97	10900	1.20				
17	615	81.80	11500	1.35				
18	580	77.24	11700	1.40				
21	495	65.77	12100	1.65				
24	435	57.68	12400	1.90	YR	77	90S-4	47
27	390	52.07	12500	2.1	YRF	77	90S-4	53
31	345	45.81	12700	2.4				
32	325	43.26	12700	2.5				
38	275	36.83	12900	3.0				
42	250	33.47	12900	3.3				
16	645	86.11	6820	0.95				
19	555	74.17	8040	1.10				
20	525	69.75	8370	1.15				
23	460	61.26	8920	1.30				
25	425	56.89	9160	1.40	YR	67	90S-4	40
27	385	51.56	9420	1.55	YRF	67	90S-4	43
30	345	46.29	9650	1.75				
35	300	39.88	9890	1.95				
37	280	37.50	9970	2.0				
43	240	32.27	10100	2.2				
49	215	28.83	10200	2.4				
50	210	28.13	10200	2.6	YR	67	90S-4	39
52	200	26.72	10100	2.7	YRF	67	90S-4	42
60	176	23.44	9730	3.2				
70	149	19.89	9270	4.0				
20	520	69.23	5990	0.85	YR	57	90S-4	34
22	485	64.85	6850	0.90	YRF	57	90S-4	37
24	430	57.29	6700	1.05				
26	400	53.22	6610	1.15	YR	57	90S-4	34
29	360	48.23	6490	1.25	YRF	57	90S-4	37



技术参数

Technical Data

P ₁ = 1.1 kW								
NA rpm	M ₂ Nm	i	Fr ₂ MAX[N]	f _s	Type	Gear unit	Motor size	 Kg
32	325	43.30	6350	1.40				
38	280	37.30	6140	1.60	YR	57	90S-4	34
40	265	35.07	6060	1.70	YRF	57	90S-4	37
46	225	30.18	5850	2.0				
52	200	26.97	5690	2.2				
53	197	26.31	5650	2.3				
56	188	24.99	5580	2.4	YR	57	90S-4	33
64	165	21.93	5400	2.7	YRF	57	90S-4	36
75	140	18.60	5170	3.2				
83	126	16.79	5030	3.6				
29	360	47.75	3500	0.85				
33	320	42.87	4850	0.95				
38	275	36.93	4720	1.10	YR	47	90S-4	28
40	260	34.73	4660	1.15	YRF	47	90S-4	28
47	225	29.88	4520	1.35				
52	200	26.70	4410	1.50				
59	177	23.59	4290	1.70				
60	175	23.28	4270	1.70				
64	164	21.81	4210	1.85				
73	145	19.27	4080	2.0				
78	134	17.89	4010	2.2				
86	122	16.22	3910	2.3	YR	47	90S-4	28
96	109	14.56	3800	2.4	YRF	47	90S-4	28
112	94	12.54	3650	2.7				
119	89	11.79	3590	2.8				
138	76	10.15	3450	3.0				
154	68	9.07	3340	3.2				
43	245	32.40	2900	0.80	YR	37	90S-4	24
49	215	28.73	3300	0.95	YRF	37	90S-4	26
57	183	24.42	3720	1.10				
73	145	19.31	3840	1.40	YR	37	90S-4	24
78	135	18.05	3790	1.50	YRF	37	90S-4	25
90	117	15.60	3660	1.70				
106	99	13.25	3520	1.90				
118	89	11.83	3430	2.1				
139	76	10.11	3290	2.2				
148	71	9.47	3230	2.4	YR	37	90S-4	24
176	60	7.97	3090	2.6	YRF	37	90S-4	25
210	50	6.67	2920	2.9				
247	43	5.67	2790	3.3				
277	38	5.06	2700	3.6				
72	145	19.35	2430	0.90	YR	27	90S-4	18
77	136	18.08	2410	0.95	YRF	27	90S-4	18



技术参数

Technical Data

P ₁ = 1.1 kW								
NA rpm	M ₂ Nm	i	Fr ₂ MAX[N]	f _s	Type	Gear unit	Motor size	 Kg
90	117	15.63	2360	1.10				
105	100	13.28	2290	1.30				
118	89	11.86	2240	1.45				
138	76	10.13	2160	1.60				
172	61	8.16	2010	1.90				
184	57	7.63	1980	1.95	YR	27	90S-4	18
212	50	6.59	1920	2.1	YRF	27	90S-4	18
250	42	5.60	1840	2.4				
280	38	5.00	1790	2.5				
328	32	4.27	1720	2.7				
350	30	4.00	1690	2.8				
415	25	3.37	1610	3.1				
203	52	13.28	1980	2.5				
228	46	11.86	1920	2.8				
267	39	10.13	1840	3.1				
287	37	9.41	1780	3.3				
331	32	8.16	1720	3.7				
354	30	7.63	1690	3.8	YR	27	80M2-2	13
410	26	6.59	1620	4.1	YRF	27	80M2-2	13
482	22	5.60	1550	4.5				
540	20	5.00	1500	4.9				
632	17	4.27	1430	5.2				
675	16	4.00	1410	5.5				
801	13	3.37	1340	6.0				
137	77	19.71	1150	1.10				
159	66	16.99	1140	1.30				
170	62	15.84	1140	1.40				
195	54	13.84	1120	1.60				
208	51	12.98	1120	1.70				
236	45	11.45	1100	1.80				
266	40	10.15	1080	1.95				
313	34	8.63	1050	2.1	YR	17	80M2-2	12
358	29	7.55	970	1.90	YRF	17	80M2-2	12
384	27	7.04	960	2.0				
439	24	6.15	940	2.3				
468	22	5.76	930	2.4				
531	20	5.09	910	2.6				
599	18	4.51	880	2.7				
704	15	3.83	850	3.0				
249	42	5.63	5680	2.6	YRX	77	90S-4	37
262	40	5.35	5590	2.6	YRXF	77	90S-4	40
296	36	4.73	5380	3.5				
203	52	4.53	4130	1.60	YRX	67	90L-6	29
214	49	4.30	4070	1.65	YRXF	67	90L-6	33



技术参数

Technical Data

P ₁ = 1.1 kW								
NA rpm	M ₂ Nm	i	Fr ₂ MAX[N]	f _s	Type	Gear unit	Motor size	 Kg
244	43	3.77	3920	2.0	YRX	67	90L-6	29
					YRXF	67	90L-6	33
309	34	4.53	3660	2.4	YRX YRXF	67	90S-4	27
326	32	4.30	3610	2.5				
371	28	3.77	3470	3.1				
438	24	3.20	3300	4.2				
485	22	2.89	3200	4.9				
551	19	2.54	3070	6.2				
583	18	2.40	3020	6.8				
685	15	2.04	2870	8.8				
754	14	1.86	2780	9.1				
870	12	1.61	2660	9.4				
1000	11	1.40	2550	9.9				
243	43	3.79	3120	1.60	YRX YRXF	57	90L-6	26
259	41	3.55	3060	1.70				
293	36	3.14	2960	1.80				
316	33	2.91	2900	2.0				
348	30	2.64	2820	2.3				
369	28	3.79	2780	2.4	YRX YRXF	57	90S-4	24
394	27	3.55	2730	2.6				
446	24	3.14	2630	2.8				
481	22	2.91	2570	3.1				
530	20	2.64	2500	3.5				
591	18	2.37	2420	3.9				
686	15	2.04	2310	4.5				
729	14	1.92	2270	4.8				
847	12	1.65	2160	5.6				
948	11	1.48	2090	6.1				
1075	9.8	1.30	2010	6.4				
P ₁ = 1.5 kW								
3.3	3920	426	73600	3.3	YR	147 YR87	90L-4	450
3.8	3380	368	73800	3.8	YRF	147 YR87	90L-4	460
0.83	15900	1705	37900	0.80	YR YRF	147 YR77	90L-4	430
0.92	14300	1536	58600	0.90				
1.1	12400	1329	63900	1.05				
1.2	10800	1166	66500	1.20				
1.4	9530	1029	68400	1.35				
1.6	8250	889	70000	1.60				
1.8	7260	784	71100	1.80				
2.0	6420	695	71900	2.0				
2.3	5780	619	72400	2.3				
2.5	5200	558	72800	2.5				



技术参数

Technical Data

P ₁ = 1.5kW								
NA rpm	M ₂ Nm	i	Fr ₂ MAX[N]	f _s	Type	Gear unit	Motor size	 Kg
1.4	9770	1043	38800	0.80				
1.6	8290	888	52700	0.95	YR	137 YR77	90L-4	290
2.0	6500	699	56200	1.25	YRF	137 YR77	90L-4	315
2.3	5640	609	57600	1.40				
1.3	10200	1090	26100	0.80				
1.5	8940	951	49900	0.90				
1.7	7750	831	53900	1.05				
1.9	6770	730	55800	1.20				
2.2	5800	629	57300	1.40	YR	137 YR77	90L-4	300
2.5	5230	560	58100	1.55	YRF	137 YR77	90L-4	320
2.9	4530	490	59000	1.75				
3.3	3950	428	59600	2.0				
3.7	3560	381	59900	2.3				
4.4	3020	323	60300	2.7				
2.7	528	4900	18500	0.9	YR	107 YR77	90L-4	205
					YRF	107 YR77	90L-4	215
2.6	5030	544	10400	0.85				
2.9	4550	492	28100	0.95				
3.4	3850	417	31700	1.10	YR	107 YR77	90L-4	210
3.8	3440	369	33400	1.25	YRF	107 YR77	90L-4	220
4.4	3000	323	34900	1.45				
3.0	4470	469	28500	0.95	YR	107 YR77	90L-4	205
					YRF	107 YR77	90L-4	210
4.2	3170	336	11300	0.95				
4.8	2790	296	22400	1.10				
5.7	2330	249	24900	1.30	YR	97 YR57	90L-4	140
6.0	2180	234	25600	1.40	YRF	97 YR57	90L-4	155
6.8	1950	209	26600	1.55				
3.0	4710	229.95	26500	0.90				
3.5	4160	203.16	30200	1.05	YR	107	100M-8	190
4.1	3530	172.34	33100	1.20	YRF	107	100M-8	195
4.4	3250	158.68	34100	1.30				
3.7	3910	251.15	31400	1.10				
4.0	3580	229.95	32900	1.20				
4.5	3160	203.16	34400	1.35	YR	107	100L-6	180
5.3	2680	172.34	35900	1.60	YRF	107	100L-6	185
5.8	2470	158.68	36200	1.75				
6.5	2210	141.83	36500	1.95				
5.5	2600	255.71	23500	1.15				
5.8	2450	241.25	24300	1.20				
6.5	2200	216.28	25600	1.35	YR	97	90L-4	115
7.6	1890	186.30	26800	1.60	YRF	97	90L-4	130
8.3	1730	170.02	27300	1.75				



技术参数

Technical Data

P ₁ = 1.5kW								
NA rpm	M ₂ Nm	i	Fr ₂ MAX[N]	f _s	Type	Gear unit	Motor size	 Kg
9.3	1530	150.78	27600	1.95				
11	1290	126.75	27900	2.3	YR	97	90L-4	115
12	1180	116.48	28000	2.5	YRF	97	90L-4	130
14	1050	103.44	28200	2.9				
15	940	92.48	28300	3.2				
7.8	1850	181.77	11400	0.85				
9.1	1580	155.34	16700	1.00				
9.9	1450	142.41	17600	1.05	YR	87	90L-4	74
11	1270	124.97	18600	1.20	YRF	87	90L-4	81
12	1200	118.43	19000	1.30				
14	1050	103.65	19600	1.45				
15	950	93.38	20000	1.65				
17	830	81.92	20000	1.85				
19	735	72.57	20000	2.1				
22	645	63.68	20000	2.4	YR	87	90L-4	74
23	615	60.35	20000	2.5	YRF	87	90L-4	81
27	535	52.82	20000	2.9				
30	485	47.58	20000	3.2				
34	425	41.74	20000	3.7				
38	375	36.84	19600	4.1				
15	940	92.97	8500	0.85				
17	830	81.80	9820	1.00	YR	77	90L-4	48
18	785	77.24	10200	1.05	YRF	77	90L-4	54
21	670	65.77	11100	1.25				
24	585	57.68	11600	1.40				
27	530	52.07	11900	1.55				
31	465	45.81	12200	1.75				
33	440	43.26	12300	1.85	YR	77	90L-4	48
38	375	36.83	12600	2.2	YRF	77	90L-4	54
42	340	33.47	12700	2.4				
49	295	29.00	12500	2.8				
56	255	25.23	12000	3.0				
60	240	23.37	11800	3.5	YR	77	90L-4	47
66	220	21.43	11500	3.8	YRF	77	90L-4	53
75	191	18.80	11000	4.1				
23	620	61.26	7280	0.95				
25	580	56.89	7810	1.05				
27	525	51.56	8370	1.15				
30	470	46.29	8830	1.30	YR	67	90L-4	42
35	405	39.88	9300	1.45	YRF	67	90L-4	45
38	380	37.50	9460	1.50				
44	330	32.27	9750	1.65				
49	295	28.83	9920	1.80				



技术参数

Technical Data

P ₁ = 1.5kW								
NA rpm	M ₂ Nm	i	Fr ₂ MAX[N]	f _s	Type	Gear unit	Motor size	 Kg
50	285	28.13	9950	1.90				
53	270	26.72	9850	2.0	YR	67	90L-4	41
60	240	23.44	9500	2.4	YRF	67	90L-4	44
71	200	19.89	9070	3.0				
79	182	17.95	8810	3.2				
<hr/>								
27	540	53.22	5140	0.85	YR	57	90L-4	36
29	c490	48.23	6010	0.90	YRF	57	90L-4	39
33	440	43.30	5920	1.00				
<hr/>								
38	380	37.30	5770	1.20				
40	355	35.07	5710	1.25	YR	57	90L-4	36
47	305	30.18	5540	1.45	YRF	57	90L-4	39
52	275	26.97	5420	1.65				
<hr/>								
54	265	26.31	5390	1.70				
56	255	24.99	5330	1.75				
64	225	21.93	5170	2.0				
76	189	18.60	4980	2.4	YR	57	90L-4	35
84	171	16.79	4850	2.6	YRF	57	90L-4	38
95	150	14.77	4700	2.9				
101	142	13.95	4630	3.0				
119	121	11.88	4440	3.4				
<hr/>								
38	375	36.93	2380	0.80				
41	355	34.73	3840	0.85	YR	47	90L-4	30
47	305	29.88	4220	1.00	YRF	47	90L-4	30
53	270	26.70	4140	1.10				
60	240	23.59	4050	1.25				
<hr/>								
61	235	23.28	4040	1.25				
65	220	21.81	3990	1.35				
73	196	19.27	3890	1.50				
79	182	17.89	3830	1.60				
87	165	16.22	3740	1.65				
97	148	14.56	3650	1.80				
112	127	12.54	3520	1.95				
120	120	11.79	3470	2.1				
139	103	10.15	3340	2.2	YR	47	90L-4	30
155	92	9.07	3240	2.4	YRF	47	90L-4	30
176	81	8.01	3140	2.5				
182	79	7.76	3060	2.1				
203	71	6.96	2980	2.3				
235	61	6.00	2860	2.6				
250	57	5.64	2810	2.7				
291	49	4.85	2700	3.0				
325	44	4.34	2610	3.3				
368	39	3.83	2520	3.7				



技术参数

Technical Data

P ₁ = 1.5kW								
NA rpm	M ₂ Nm	i	Fr ₂ MAX[N]	f _s	Type	Gear unit	Motor size	 Kg
73	196	19.31	2660	1.00	YR	37	90L-4	25
78	183	18.05	2840	1.10	YRF	37	90L-4	27
90	159	15.60	3160	1.25				
106	135	13.25	3350	1.40				
119	120	11.83	3270	1.50				
140	103	10.11	3160	1.65				
149	96	9.47	3110	1.75				
177	81	7.97	2980	1.95	YR	37	90L-4	25
211	68	6.67	2820	2.1	YRF	37	90L-4	27
249	58	5.67	2710	2.5				
279	51	5.06	2630	2.6				
326	44	4.32	2520	2.9				
348	41	4.05	2470	3.0				
414	35	3.41	2360	3.2				
211	68	13.25	2850	2.8	YR	37	90S-2	24
237	61	11.83	2770	3.0	YRF	37	90S-2	25
277	52	10.11	2650	3.3				
296	48	9.47	2610	3.5				
351	41	7.97	2480	3.8				
90	159	15.63	1700	0.80				
106	135	13.28	2020	0.95				
119	121	11.86	2080	1.05				
139	103	10.13	2030	1.20				
173	83	8.16	1880	1.40				
185	78	7.63	1860	1.45	YR	27	90L-4	19
214	67	6.59	1810	1.60	YRF	27	90L-4	19
252	57	5.60	1750	1.75				
282	51	5.00	1710	1.85				
330	43	4.27	1650	2.0				
353	41	4.00	1630	2.1				
418	34	3.37	1560	2.3				
236	61	11.86	1820	2.1				
276	52	10.13	1760	2.4				
343	42	8.16	1640	2.8				
367	39	7.63	1610	2.9				
425	34	6.59	1550	3.2	YR	27	90S-2	18
500	29	5.60	1490	3.5	YRF	27	90S-2	18
560	26	5.00	1450	3.7				
656	22	4.27	1390	4.0				
700	21	4.00	1360	4.2				
831	17	3.37	1300	4.6				
250	57	5.63	5580	1.90	YR	77	90L-4	38
264	54	5.35	5490	1.90	YRF	77	90L-4	41
298	48	4.73	5300	2.6				



技术参数

Technical Data

P₁ = 1.5kW								
------------------------------	--	--	--	--	--	--	--	--

N _A rpm	M ₂ Nm	i	Fr ₂ MAX[N]	f _s	Type	Gear unit	Motor size	Kg
349	41	4.04	5050	3.5				
381	38	3.70	4920	4.1				
434	33	3.25	4720	5.5	YR	77	90L-4	38
458	31	3.08	4650	6.2	YRF	77	90L-4	41
523	27	2.70	4460	7.9				
581	25	2.43	4310	8.7				
<hr/>								
312	46	4.53	3570	1.80				
328	44	4.30	3520	1.85				
374	38	3.77	3390	2.3				
441	33	3.20	3230	3.1				
488	29	2.89	3140	3.6	YRX	67	90L-4	29
555	26	2.54	3020	4.6	YRXF	67	90L-4	33
588	24	2.40	2970	5.0				
690	21	2.04	2820	6.4				
759	19	1.86	2740	6.7				
876	16	1.61	2620	7.0				
1005	14	1.40	2510	7.3				
<hr/>								
372	39	3.79	2700	1.80				
397	36	3.55	2650	1.90				
450	32	3.14	2560	2.0				
484	30	2.91	2510	2.3				
534	27	2.64	2440	2.6	YRX	57	90L-4	26
595	24	2.37	2360	2.9	YRXF	57	90L-4	28
691	21	2.04	2260	3.3				
734	20	1.92	2220	3.5				
853	17	1.65	2120	4.1				
955	15	1.48	2050	4.5				
1080	13	1.30	1980	4.7				

P₁ = 2.2kW								
------------------------------	--	--	--	--	--	--	--	--

0.84	22600	1670	120000	0.80				
0.98	19700	1438	120000	0.90				
1.1	17500	1279	120000	1.05				
1.3	15300	1123	120000	1.15	YR	167 YR97	100L1-4	770
1.4	13600	999	120000	1.30	YRF	167 YR97	100L1-4	770
1.6	11800	861	120000	1.55				
1.9	10400	760	120000	1.75				
2.1	8730	656	120000	2.1				
<hr/>								
2.6	7200	533	71100	1.80				
3.1	6190	462	72100	2.1				
3.3	5820	426	72400	2.2	YR	147 YR87	100L1-4	460
3.8	5030	368	72900	2.6	YRF	147 YR87	100L1-4	465
4.3	4450	326	73300	2.9				



技术参数

Technical Data

P ₁ = 2.2kW								
NA rpm	M ₂ Nm	i	Fr ₂ MAX[N]	f _s	Type	Gear unit	Motor size	 Kg
1.2	16000	1166	36000	0.80				
1.4	14100	1029	60300	0.90				
1.6	12200	889	64200	1.05				
1.8	10800	784	66600	1.20	YR	147 YR77	100L1-4	435
2.0	9520	695	68500	1.35	YRF	147 YR77	100L1-4	445
2.3	8550	619	69700	1.50				
2.5	7690	558	70600	1.70				
2.9	6730	489	71600	1.95				
2.0	9620	699	41800	0.85	YR	137 YR77	100L1-4	295
2.3	8350	609	52500	0.95	YRF	137 YR77	100L1-4	320
1.9	10000	730	33300	0.80				
2.2	8610	629	51400	0.95				
2.5	7730	560	54000	1.05				
2.9	6720	490	55900	1.20				
3.3	5860	428	57200	1.35	YR	137 YR77	100L1-4	305
3.7	5260	381	58100	1.50	YRF	137 YR77	100L1-4	330
4.4	4460	323	59000	1.80				
4.8	4020	291	59500	2.0				
5.5	3510	255	59900	2.3				
6.3	3070	223	60300	2.6				
4.4	4450	323	28600	0.95				
4.9	3920	285	31400	1.10	YR	107 YR77	100L1-4	220
5.6	3470	253	33300	1.25	YRF	107 YR77	100L1-4	225
6.6	2940	214	35100	1.45				
4.4	4540	325	28100	0.95	YR	107 YR77	100L1-4	215
					YRF	107 YR77	100L1-4	220
6.8	2880	209	21800	1.05	YR	97 YR57	100L1-4	145
					YRF	97 YR57	100L1-4	165
3.1	6680	222.60	55900	1.20				
3.7	5660	188.45	57500	1.40	YR	137	Y132S-8	295
4.0	5230	174.40	58100	1.55	YRF	137	Y132S-8	320
4.5	4690	156.31	58800	1.70				
5.0	4240	141.12	59300	1.90				
5.5	3850	128.18	59600	2.1	YR	137	Y132S-8	295
6.2	3410	113.72	60000	2.3	YRF	137	Y132S-8	320
6.8	3100	103.20	60300	2.6				
4.6	4540	203.16	28100	0.95				
5.5	3850	172.34	31700	1.10	YR	107	Y112M-6	190
5.9	3550	158.68	33000	1.20	YRF	107	Y112M-6	195
6.6	3170	141.83	34400	1.35				
5.6	3740	251.15	32200	1.15	YR	107	100L1-4	180
6.1	3430	229.95	33500	1.25	YRF	107	100L1-4	185



技术参数

Technical Data

P ₁ = 2.2kW								
NA rpm	M ₂ Nm	i	Fr ₂ MAX[N]	f _s	Type	Gear unit	Motor size	 Kg
6.9	3030	203.16	34900	1.40	YR	107	100L1-4	180
					YRF	107	100L1-4	185
8.2	2570	172.34	36100	1.65	YR YRF	107	100L1-4	180 185
8.9	2360	158.68	36300	1.80				
9.9	2110	141.83	36600	2.0				
11	1900	127.68	36900	2.3				
12	1720	115.63	37000	2.5				
14	1530	102.53	37200	2.8				
15	1380	92.70	37300	3.1				
6.5	3220	216.28	7030	0.95				
7.6	2780	186.30	22500	1.10	YRF	97	100L1-4	140
8.3	2530	170.02	23900	1.20				
9.3	2250	150.78	25300	1.35	YR YRF	97	100L1-4	125 140
11	1890	126.75	26800	1.60				
12	1740	116.48	27300	1.75				
14	1540	103.44	27600	1.95				
15	1380	92.48	27800	2.2				
17	1240	83.15	28000	2.4				
20	1080	72.17	28200	2.8				
22	970	65.21	27700	3.1				
24	890	59.92	27000	3.4				
27	795	53.21	26100	3.8				
30	710	47.58	25300	4.2				
11	1860	124.97	10100	0.85				
12	1760	118.43	15200	0.90				
14	1540	103.65	17000	1.00				
15	1390	93.38	17900	1.10				
17	1220	81.92	18900	1.25				
19	1080	72.57	19500	1.45	YR YRF	87	100L1-4	82 89
22	950	63.68	20000	1.65				
23	900	60.35	20000	1.70				
27	785	52.82	20000	1.95				
30	710	47.58	20000	2.2				
34	620	41.74	19900	2.5				
38	550	36.84	19200	2.8				
43	485	32.66	18500	3.2				
41	515	34.40	18800	2.9				
45	470	31.40	18300	3.3				
51	415	27.84	17700	3.7				
60	350	23.40	16800	4.5				
66	320	21.51	16400	4.7				
21	980	65.77	5470	0.85	YR	77	100L1-4	55
24	860	57.68	9540	0.95	YRF	77	100L1-4	61



技术参数

Technical Data

P ₁ = 2.2kW								
NA rpm	M ₂ Nm	i	Fr ₂ MAX[N]	f _s	Type	Gear unit	Motor size	 Kg
27	775	52.07	10300	1.05	YR	77	100L1-4	55
31	685	45.81	11000	1.20	YRF	77	100L1-4	61
33	645	43.26	11300	1.25				
38	550	36.83	11800	1.50	YR	77	100L1-4	55
42	500	33.47	12100	1.65	YRF	77	100L1-4	61
49	430	29.00	12100	1.90				
56	375	25.23	11700	2.1				
60	350	23.37	11400	2.4				
66	320	21.43	11200	2.6				
75	280	18.80	10800	2.8	YR	77	100L1-4	54
79	265	17.82	10600	2.9	YRF	77	100L1-4	60
90	230	15.60	10200	3.2				
100	210	14.05	9910	3.4				
35	595	39.88	7630	1.00				
38	560	37.50	8020	1.00	YR	67	100L1-4	49
44	480	32.27	8750	1.10	YRF	67	100L1-4	52
49	430	28.83	9140	1.20				
60	350	23.44	9140	1.60				
71	295	19.89	8760	2.0				
79	270	17.95	8530	2.2				
89	235	15.79	8240	2.4				
95	220	14.91	8110	2.5	YR	67	100L1-4	48
111	189	12.70	7760	2.8	YRF	67	100L1-4	51
122	172	11.54	7560	2.9				
141	149	10.00	7250	3.2				
162	130	8.70	6960	3.4				
181	116	7.79	6760	3.3				
38	555	37.30	4490	0.80				
40	525	35.07	5110	0.85	YR	57	100L1-4	43
47	450	30.18	5030	1.00	YRF	57	100L1-4	46
52	400	26.97	4960	1.10				
64	325	21.93	4800	1.40				
76	275	18.60	4660	1.60				
84	250	16.79	4570	1.80				
95	220	14.77	4450	2.0				
101	210	13.95	4390	2.1	YR	57	100L1-4	42
119	177	11.88	4230	2.3	YRF	57	100L1-4	45
131	161	10.79	4140	2.4				
151	139	9.35	4000	2.7				
156	135	9.06	3980	2.8				
177	119	7.97	3850	3.0				
107	197	26.31	4340	2.3	YR	57	90L-2	35
112	187	24.99	4290	2.4	YRF	57	90L-2	38



技术参数

Technical Data

P ₁ = 2.2kW								
NA rpm	M ₂ Nm	i	Fr ₂ MAX[N]	f _s	Type	Gear unit	Motor size	 Kg
128	164	21.93	4160	2.8	YR YRF	57	90L-2	35
151	139	18.60	3990	3.2				
167	126	16.79	3890	3.6				
190	111	14.77	3760	3.9				
201	104	13.95	3710	4.1				
73	285	19.27	3550	1.05	YR YRF	47	100L1-4	37
87	240	16.22	3460	1.15				
97	215	14.56	3400	1.20				
112	187	12.54	3310	1.35				
120	176	11.79	3270	1.40				
139	151	10.15	3160	1.50				
155	135	9.07	3090	1.65				
176	119	8.01	3000	1.70				
182	116	7.76	2910	1.40				
203	104	6.96	2840	1.55				
235	89	6.00	2740	1.75				
250	84	5.64	2700	1.85				
291	72	4.85	2600	2.1				
325	65	4.34	2530	2.3				
368	57	3.83	2440	2.5				
121	174	23.28	3260	1.70	YR YRF	47	90L-2	30
129	163	21.81	3220	1.85				
146	144	19.27	3130	2.1				
157	134	17.89	3080	2.2				
173	121	16.22	3010	2.3				
193	109	14.56	2930	2.4				
224	94	12.54	2830	2.7				
238	88	11.79	2780	2.8				
277	76	10.15	2680	3.0				
310	68	9.07	2600	3.2				
351	60	8.01	2510	3.4				
90	230	15.60	1070	0.85				
106	198	13.25	1660	0.95				
119	176	11.83	1990	1.05				
140	151	10.11	2360	1.15	YR YRF	37	100L1-4	31
149	141	9.47	2480	1.20				
177	119	7.97	2750	1.30				
211	99	6.67	2470	1.45				
249	84	5.67	2570	1.70				
279	75	5.06	2500	1.80				
326	64	4.32	2410	1.95				
348	60	4.05	2370	2.0				
414	51	3.41	2270	2.2				



技术参数

Technical Data

P ₁ = 2.2kW								
N _A rpm	M ₂ Nm	i	Fr ₂ MAX[N]	f _s	Type	Gear unit	Motor size	 Kg
146	144	19.31	2440	1.40	YR	37	90L-2	25
156	135	18.05	2560	1.50	YRF	37	90L-2	27
180	117	15.60	2780	1.70				
212	99	13.25	2700	1.9				
237	89	11.83	2630	2.1				
278	76	10.11	2540	2.3				
297	71	9.47	2500	2.4				
352	60	7.97	2390	2.6	YR	37	90L-2	25
421	50	6.67	2260	2.9	YRF	37	90L-2	27
496	42	5.67	2170	3.4				
555	38	5.06	2100	3.6				
650	32	4.32	2010	3.9				
694	30	4.05	1980	4.0				
824	26	3.41	1880	4.4				
139	151	10.13	1120	0.80				
214	98	6.59	1130	1.10				
252	83	5.60	1390	1.20	YR	27	100L1-4	26
282	75	5.00	1540	1.30	YRF	27	100L1-4	26
330	64	4.27	1540	1.35				
353	60	4.00	1520	1.45				
418	50	3.37	1470	1.55				
212	99	13.28	1710	1.30				
237	89	11.86	1680	1.45				
277	76	10.13	1640	1.60				
344	61	8.16	1520	1.90				
369	57	7.63	1500	1.95	YR	27	100L1-4	20
426	49	6.59	1460	2.2	YRF	27	100L1-4	19
502	42	5.60	1410	2.4				
562	37	5.00	1380	2.5				
658	32	4.27	1330	2.7				
703	30	4.00	1310	2.8				
834	25	3.37	1250	3.1				
298	70	4.73	5180	1.75				
349	60	4.04	4950	2.4				
381	55	3.70	4820	2.8				
434	48	3.25	4640	3.8				
458	46	3.08	4560	4.2	YRX	77	100L1-4	45
523	40	2.70	4380	5.4	YRXF	77	100L1-4	48
581	36	2.43	4250	5.9				
662	32	2.13	4080	6.3				
750	28	1.88	3920	6.7				
846	25	1.67	3780	7.0				
991	21	1.42	3590	7.3				



技术参数

Technical Data

P ₁ = 2.2kW								
NA rpm	M ₂ Nm	i	Fr ₂ MAX[N]	f _s	Type	Gear unit	Motor size	 Kg
374	56	3.77	3280	1.55				
441	48	3.20	3130	2.1				
488	43	2.89	3050	2.5				
555	38	2.54	2940	3.1	YRX	67	100L1-4	36
588	36	2.40	2890	3.4	YRXF	67	100L1-4	40
690	30	2.04	2760	4.4				
759	28	1.86	2680	4.6				
876	24	1.61	2570	4.8				
1005	21	1.40	2460	5.0				
450	47	3.14	2450	1.40				
534	39	2.64	2340	1.75				
595	35	2.37	2280	1.95				
691	30	2.04	2190	2.3	YRX	57	100L1-4	33
734	29	1.92	2150	2.4	YRXF	57	100L1-4	35
853	25	1.65	2060	2.8				
955	22	1.48	1990	3.1				
1080	19	1.30	1930	3.3				
P ₁ = 3.0kW								
1.2	21200	1123	120000	0.85				
1.4	18900	999	120000	0.95				
1.6	16300	861	120000	1.10	YR	167 YR97	100L2-4	770
1.8	14400	760	120000	1.25	YRF	167 YR97	100L2-4	780
2.1	12200	656	120000	1.50				
2.8	9330	503	120000	1.95				
2.6	9990	533	67800	1.30				
3.0	8610	462	69600	1.50				
3.3	8060	426	70200	1.60	YR	147 YR87	100L2-4	465
3.8	6960	368	71400	1.85	YRF	147 YR87	100L2-4	470
4.3	6150	326	72100	2.1				
5.0	5230	280	72800	2.5				
1.6	16900	889	21900	0.75				
1.8	14900	784	52000	0.85				
2.0	13200	695	62300	1.00	YR	147 YR77	100L2-4	440
2.3	11800	619	64900	1.10	YRF	147 YR77	100L2-4	450
2.5	10600	558	66900	1.20				
2.9	9280	490	48100	0.85				
3.3	8100	428	53200	1.00				
3.7	7260	381	54900	1.10				
4.3	6160	323	56800	1.30	YR	137 YR77	100L2-4	310
4.8	5540	291	57700	1.45	YRF	137 YR77	100L2-4	335
5.5	4840	255	58600	1.65				
6.3	4240	223	59300	1.90				



技术参数

Technical Data

P ₁ = 3.0kW								
NA rpm	M ₂ Nm	i	Fr ₂ MAX[N]	f _s	Type	Gear unit	Motor size	 Kg
2.7	9990	517	34100	0.80	YR	137 YR77	100L2-4	300
3.1	8760	453	50700	0.90	YRF	137 YR77	100L2-4	325
5.5	4790	253	23500	0.90	YR	107 YR77	100L2-4	225
6.5	4060	214	30700	1.05	YRF	107 YR77	100L2-4	230
7.5	3550	187	33000	1.20				
5.5	4930	256	17400	0.85	YR	107 YR77	100L2-4	215
					YRF	107 YR77	100L2-4	225
3.2	8860	222.60	50300	0.90				
3.8	7500	188.45	54400	1.05	YR	137	132M-8	305
4.1	6940	174.40	55500	1.15	YRF	137	132M-8	325
4.6	6220	156.31	56700	1.30				
5.1	5620	141.12	57600	1.40				
5.6	5100	128.18	58300	1.55	YR	137	132M-8	305
6.3	4520	113.72	59000	1.75	YRF	137	132M-8	325
7.0	4110	103.20	59400	1.95				
8.1	3530	88.70	59900	2.3				
4.2	6780	222.60	55800	1.20	YR	137	132S-6	295
5.0	5740	188.45	57400	1.40	YRF	137	132S-6	320
5.4	5320	174.40	58000	1.50				
6.0	4760	156.31	58700	1.70				
6.7	4300	141.12	59200	1.85				
7.3	3910	128.18	59600	2.1	YR	137	132S-6	295
8.3	3470	113.72	60000	2.3	YRF	137	132S-6	320
9.1	3150	103.20	60200	2.5				
5.9	4840	158.68	21600	0.90	YR	107	132S-6	195
6.6	4320	141.83	29300	1.00	YRF	107	132S-6	205
7.4	3890	127.68	31500	1.10				
6.1	4710	229.95	26500	0.90	YR	107	100L2-4	185
6.9	4160	203.16	30200	1.05	YRF	107	100L2-4	190
8.1	3530	172.34	33100	1.20				
8.8	3250	158.68	34100	1.30				
9.9	2900	141.83	35300	1.50				
11	2610	127.68	36000	1.65				
12	2370	115.63	36300	1.80				
14	2100	102.53	36700	2.1				
15	1900	92.70	36900	2.3				
18	1610	78.57	35900	2.7				
19	1490	72.88	35200	2.9				
9.3	3090	150.78	16200	0.95	YR	97	100L2-4	125
11	2590	126.75	23600	1.15	YRF	97	100L2-4	145
12	2380	116.48	24700	1.25				
14	2120	103.44	25900	1.40				



技术参数

Technical Data

P ₁ = 3.0kW								
NA rpm	M ₂ Nm	i	Fr ₂ MAX[N]	f _s	Type	Gear unit	Motor size	 Kg
15	1890	92.48	26800	1.60				
17	1700	83.15	27300	1.75				
19	1480	72.17	27700	2.0				
21	1330	65.21	27000	2.3				
23	1230	59.92	26400	2.5	YR	97	100L2-4	125
26	1090	53.21	25600	2.8	YRF	97	100L2-4	145
29	970	47.58	24800	3.1				
33	880	42.78	24000	3.4				
38	760	37.13	23100	4.0				
42	680	33.25	22400	4.3				
15	1910	93.38	13630	0.80				
17	1680	81.92	16000	0.90	YR	87	100L2-4	86
19	1490	72.57	17400	1.05	YRF	87	100L2-4	93
22	1300	63.68	18400	1.20				
23	1230	60.35	18800	1.25				
27	1080	52.82	19500	1.45				
29	970	47.58	19900	1.60	YR	87	100L2-4	86
34	850	41.74	19400	1.80	YRF	87	100L2-4	93
38	755	36.84	18700	2.1				
43	670	32.66	18100	2.3				
50	570	27.88	17400	2.6				
41	705	34.40	18400	2.1				
45	640	31.40	17900	2.4				
50	570	27.84	17400	2.7				
60	480	23.40	16500	3.2	YR	87	100L2-4	85
65	440	21.51	16100	3.4	YRF	87	100L2-4	92
73	390	19.10	15600	3.7				
82	350	17.08	15100	4.0				
91	315	15.35	14600	4.3				
31	940	45.81	8670	0.85				
32	890	43.26	9270	0.95	YR	77	100L2-4	59
38	755	36.83	10500	1.10	YRF	77	100L2-4	65
42	685	33.47	11000	1.20				
48	595	29.00	11600	1.40	YR	77	100L2-4	59
55	515	25.23	11300	1.50	YRF	77	100L2-4	65
60	480	23.37	11100	1.70				
65	440	21.43	10800	1.85				
74	385	18.80	10500	2.0				
79	365	17.82	10300	2.1	YR	77	100L2-4	58
90	320	15.60	9980	2.3	YRF	77	100L2-4	64
100	290	14.05	9700	2.5				
114	250	12.33	9350	2.7				
129	225	10.88	9030	3.0				



技术参数

Technical Data

P ₁ = 3.0kW								
N _A rpm	M ₂ Nm	i	Fr ₂ MAX[N]	f _s	Type	Gear unit	Motor size	 Kg
145	197	9.64	8720	3.2				
163	176	8.59	8500	3.6	YR	77	100L2-4	58
181	158	7.74	8240	3.9	YRF	77	100L2-4	64
206	139	6.79	7920	4.2				
60	480	23.44	8730	1.15				
70	405	19.89	8420	1.45				
78	365	17.95	8230	1.60				
89	325	15.79	7980	1.75	YR	67	100L2-4	52
94	305	14.91	7860	1.80	YRF	67	100L2-4	55
110	260	12.70	7550	2.0				
121	235	11.54	7360	2.1				
140	205	10.00	7090	2.3				
52	550	26.97	4330	0.80	YR	57	100L2-4	47
					YRF	57	100L2-4	50
64	450	21.93	4380	1.00	YR	57	100L2-4	46
75	380	18.60	4300	1.20	YRF	57	100L2-4	49
83	345	16.79	4250	1.30				
95	300	14.77	4160	1.45				
100	285	13.95	4130	1.50				
118	245	11.88	4010	1.65				
130	220	10.79	3940	1.75				
150	191	9.35	3820	1.95				
155	185	9.06	3810	2.0	YR	57	100L2-4	46
176	163	7.97	3700	2.2	YRF	57	100L2-4	49
186	154	7.53	3650	2.3				
218	131	6.41	3520	2.6				
240	119	5.82	3430	2.7				
277	103	5.05	3310	3.0				
319	90	4.39	3190	3.1				
128	225	21.93	3950	2.0				
151	190	18.60	3820	2.4				
167	172	16.79	3730	2.6	YR	57	100L-2	42
190	151	14.77	3620	2.9	YRF	57	100L-2	45
201	143	13.95	3570	3.0				
236	122	11.88	3440	3.3				
259	110	10.79	3360	3.5				
86	330	16.22	2030	0.85	YR	47	100L2-4	41
96	300	14.56	2500	0.90	YRF	47	100L2-4	41
112	255	12.54	3040	0.95				
119	240	11.79	3040	1.00				
138	210	10.15	2970	1.10	YR	47	100L2-4	41
154	186	9.07	2910	1.20	YRF	47	100L2-4	41
175	164	8.01	2840	1.25				



技术参数

Technical Data

P ₁ = 3.0kW								
NA rpm	M ₂ Nm	i	Fr ₂ MAX[N]	f _s	Type	Gear unit	Motor size	 Kg
181	159	7.76	2740	1.05				
201	143	6.96	2680	1.10				
233	123	6.00	2610	1.25	YR	47	100L2-4	41
248	115	5.64	2580	1.35	YRF	47	100L2-4	41
288	99	4.85	2490	1.50				
323	89	4.34	2430	1.65				
365	78	3.83	2360	1.85				
237	121	11.79	2670	2.0				
276	104	10.15	2580	2.2				
309	93	9.07	2510	2.4				
349	82	8.01	2430	2.5				
361	79	7.76	2370	2.1	YR	47	100L-2	37
402	71	6.96	2310	2.2	YRF	47	100L-2	37
467	61	6.00	2220	2.5				
496	58	5.64	2190	2.7				
577	50	4.85	2100	3.0				
646	44	4.34	2040	3.3				
731	39	3.83	1970	3.7				
139	205	10.11	780	0.80	YR	37	100L2-4	35
148	194	9.47	1010	0.85	YRF	37	100L2-4	37
176	163	7.97	1510	0.95				
210	137	6.67	1250	1.05				
247	116	5.67	1630	1.25				
277	104	5.06	1830	1.30	YR	37	100L2-4	35
324	88	4.32	2070	1.45	YRF	37	100L2-4	37
346	83	4.05	2140	1.45				
411	70	3.41	2180	1.60				
277	103	10.11	2340	1.65				
296	97	9.47	2380	1.70				
351	82	7.97	2290	1.90				
420	68	6.67	2170	2.1	YR	37	100L-2	31
494	58	5.67	2090	2.5	YRF	37	100L-2	33
553	52	5.06	2030	2.6				
648	44	4.32	1950	2.9				
692	41	4.05	1920	3.0				
821	35	3.41	1840	3.2				
250	115	5.60	360	0.85				
280	102	5.00	615	0.95	YR	27	100L2-4	30
328	87	4.27	910	1.00	YRF	27	100L2-4	30
350	82	4.00	1010	1.05				
415	69	3.37	1230	1.15				
425	67	6.59	1260	1.55	YR	27	100L-2	26
500	57	5.60	1330	1.75	YRF	27	100L-2	26



技术参数

Technical Data

P ₁ = 3.0kW											
NA rpm	M ₂ Nm	i	Fr ₂ MAX[N]	f _s	Type	Gear unit	Motor size	 Kg			
560	51	5.00	1300	1.85	YR	27	100L-2	26			
656	44	4.27	1260	2.0							
700	41	4.00	1240	2.1							
831	35	3.37	1200	2.3							
217	132	6.45	7130	1.45	YRX	87	100L2-4	66			
252	114	5.56	6830	2.0							
276	104	5.07	6650	2.4							
311	92	4.50	6430	3.2							
370	77	3.78	6100	3.9							
296	97	4.73	5050	1.25	YRX	77	100L2-4	49			
347	83	4.04	4830	1.75							
378	76	3.70	4720	2.0							
431	67	3.25	4550	2.7							
455	63	3.08	4480	3.1							
371	77	3.77	3150	1.15	YRX	67	100L2-4	40			
438	66	3.20	3030	1.55							
485	59	2.89	2950	1.80							
551	52	2.54	2850	2.3							
583	49	2.40	2810	2.5							
685	42	2.04	2690	3.2							
754	38	1.86	2610	3.3							
870	33	1.61	2510	3.5							
1000	29	1.40	2410	3.6							
446	64	3.14	2330	1.00					YRX	57	100L2-4
530	54	2.64	2240	1.30							
591	49	2.37	2180	1.40							
686	42	2.04	2100	1.65							
729	39	1.92	2070	1.75							
847	34	1.65	1990	2.0							
948	30	1.48	1930	2.3							
1075	27	1.30	1870	2.4							
YRXF					57	100L2-4	39				
P ₁ = 4.0kW											
1.7	21500	861	120000	0.85	YRX	167 YR97	112M-4	780			
1.9	19000	760	120000	0.95							
2.2	16100	656	120000	1.10							
2.8	12400	503	120000	1.45							
3.8	9260	376	120000	1.95							
4.2	8240	335	120000	2.2							
2.7	13200	533	62200	1.00	YR	147 YR87	112M-4	470			
3.1	11400	462	65600	1.15							
3.3	10600	426	66800	1.20							
3.9	9190	368	68900	1.40							
4.4	8130	326	70200	1.60							
YRPF									147 YR87	112M-4	475



技术参数

Technical Data

P ₁ = 4.0kW								
N _A rpm	M ₂ Nm	i	Fr ₂ MAX[N]	f _s	Type	Gear unit	Motor size	 Kg
5.1	6920	280	71400	1.90				
5.7	6110	247	72100	2.1	YR	147 YR87	112M-4	470
6.7	5280	214	72800	2.5	YRF	147 YR87	112M-4	475
7.5	4670	189	73200	2.8				
9.0	3920	159	73600	3.3				
2.3	15500	619	43200	0.85				
2.5	14000	558	60500	0.95	YR	147 YR77	112M-4	445
2.9	12300	489	64100	1.05	YRF	147 YR77	112M-4	455
3.4	10400	415	67200	1.25				
3.7	9570	381	42700	0.85				
4.4	8120	323	53100	1.00	YR	137 YR77	112M-4	315
4.9	7310	291	54800	1.10	YRF	137 YR77	112M-4	340
5.6	6390	255	56400	1.25				
6.4	5600	223	57600	1.45				
3.8	9560	376	43000	0.85	YR	137 YR77	112M-4	305
4.2	8600	339	51400	0.95	YRF	137 YR77	112M-4	330
4.8	7540	297	54300	1.05				
7.6	4680	187	27200	0.90	YR	107 YR77	112M-4	230
					YRF	107 YR77	112M-4	235
7.3	4890	193	19000	0.90	YR	107 YR77	112M-4	225
8.2	4380	172	29000	1.00	YRF	107 YR77	112M-4	230
4.4	8660	163.31	69500	1.50				
4.9	7790	146.91	70500	1.65	YR	147	160M1-8	440
6.0	6360	119.86	71900	2.0	YRF	147	160M1-8	450
6.6	5800	109.31	72400	2.2				
4.1	9250	174.40	48400	0.85				
4.6	8290	156.31	52700	0.95				
5.1	7490	141.12	54400	1.05	YR	137	160M1-8	310
5.6	6800	128.18	55700	1.20	YRF	137	160M1-8	335
6.3	6030	113.72	57000	1.35				
7.0	5470	103.20	57800	1.45				
4.3	8860	222.60	50300	0.90				
5.1	7500	188.45	54400	1.05				
5.5	6940	174.40	55500	1.15	YR	137	132M1-6	305
6.1	6220	156.31	56700	1.30	YRF	137	132M1-6	325
6.8	5620	141.12	57600	1.40				
7.5	5100	128.18	58300	1.55				
8.4	4520	113.72	59000	1.75				
9.3	4110	103.20	59400	1.95	YR	137	132M1-6	305
11	3530	88.70	59900	2.3	YRF	137	132M1-6	325



技术参数

Technical Data

P ₁ = 4.0kW								
NA rpm	M ₂ Nm	i	Fr ₂ MAX[N]	f _s	Type	Gear unit	Motor size	 Kg
8.2	4640	172.34	27500	0.95				
9.0	4270	158.68	29600	1.00				
10	3820	141.83	31900	1.15				
11	3430	127.68	33400	1.25				
12	3110	115.63	34600	1.40				
14	2760	102.53	35700	1.55	YR	107	112M-4	190
15	2490	92.70	36200	1.70	YRF	107	112M-4	195
18	2110	78.57	34900	2.0				
19	1960	72.88	34200	2.2				
22	1760	65.60	33200	2.4				
24	1600	59.41	32300	2.7				
27	1420	52.68	31300	3.0				
12	3130	116.48	13800	0.95				
14	2780	103.44	22400	1.10				
15	2490	92.48	24100	1.20				
17	2240	83.15	25400	1.35				
20	1940	72.17	26600	1.55				
22	1750	65.21	26000	1.70	YR	97	112M-4	135
24	1610	59.92	25500	1.85	YRF	97	112M-4	150
27	1430	53.21	24700	2.1				
30	1280	47.58	24000	2.3				
33	1150	42.78	23400	2.6				
38	1000	37.13	22500	3.0				
43	890	33.25	21800	3.2				
44	860	32.05	21600	3.0				
52	730	27.19	20600	3.5	YR	97	112M-4	130
57	675	25.03	20100	4.2	YRF	97	112M-4	150
63	600	22.37	19500	4.5				
71	540	20.14	18900	4.8				
22	1710	63.68	13300	0.90	YR	87	112M-4	91
24	1620	60.35	13900	0.95	YRF	87	112M-4	98
27	1420	52.82	15200	1.10				
30	1280	47.58	16000	1.20				
34	1120	41.74	16800	1.40	YR	87	112M-4	91
39	990	36.84	17400	1.55	YRF	87	112M-4	98
43	880	32.66	17500	1.75				
51	750	27.88	16800	2.0				
41	930	34.40	17600	1.60				
45	840	31.40	17400	1.85				
51	750	27.84	16800	2.1	YR	87	112M-4	90
61	630	23.40	16100	2.5	YRF	87	112M-4	97
66	580	21.51	15700	2.6				
74	515	19.10	15200	2.8				
83	460	17.08	14700	3.0				



技术参数

Technical Data

P ₁ = 4.0kW								
NA rpm	M ₂ Nm	i	Fr ₂ MAX[N]	f _s	Type	Gear unit	Motor size	 Kg
92	415	15.35	14300	3.2	YR	87	112M-4	90
107	360	13.33	13700	3.6	YRF	87	112M-4	97
119	320	11.93	13300	3.8				
39	990	36.83	4070	0.85				
42	900	33.47	9100	0.90	YR	77	112M-4	65
49	780	29.00	10300	1.05	YRF	77	112M-4	71
56	680	25.23	10800	1.15				
61	630	23.37	10600	1.30				
66	575	21.43	10400	1.40				
76	505	18.80	10100	1.55				
80	480	17.82	9950	1.65				
91	420	15.60	9630	1.75				
101	380	14.05	9380	1.90				
115	330	12.33	9070	2.1	YR	77	112M-4	64
131	295	10.88	8780	2.3	YRF	77	112M-4	70
147	260	9.64	8500	2.4				
165	230	8.59	8320	2.7				
183	210	7.74	8070	2.9				
209	183	6.79	7770	3.2				
237	161	5.99	7490	3.4				
267	143	5.31	7230	3.6				
71	535	19.89	7960	1.10				
79	485	17.95	7800	1.20				
90	425	15.79	7600	1.30				
95	400	14.91	7510	1.35				
112	340	12.70	7240	1.50				
123	310	11.54	7080	1.60				
142	270	10.00	6840	1.75	YR	67	112M-4	59
163	235	8.70	6600	1.90	YRF	67	112M-4	62
182	210	7.79	6440	1.80				
193	198	7.36	6340	1.85				
227	169	6.27	6070	1.95				
249	153	5.70	5920	2.0				
288	133	4.93	5680	2.2				
331	116	4.29	5460	2.3				
76	500	18.60	3520	0.90	YR	57	112M-4	53
85	450	16.79	3830	1.00	YRF	57	112M-4	56
96	395	14.77	3800	1.10				
102	375	13.95	3780	1.15				
120	320	11.88	3710	1.25				
132	290	10.79	3660	1.35	YR	57	112M-4	53
152	250	9.35	3580	1.45	YRF	57	112M-4	56
157	245	9.06	3590	1.55				
178	215	7.97	3500	1.65				



技术参数

Technical Data

P ₁ = 4.0kW								
NA rpm	M ₂ Nm	i	Fr ₂ MAX[N]	f _s	Type	Gear unit	Motor size	 Kg
189	205	7.53	3470	1.75	YR YRF	57	112M-4	53 56
222	172	6.41	3350	1.95				
244	157	5.82	3280	2.0				
281	136	5.05	3180	2.3				
323	118	4.39	3070	2.4				
140	275	10.15	1960	0.85	YR YRF	47	112M-4	48 48
157	245	9.07	2350	0.90				
177	215	8.01	2640	0.95				
204	187	6.96	2480	0.85				
237	161	6.00	2430	0.95				
252	152	5.64	2410	1.00				
293	131	4.85	2350	1.15				
327	117	4.34	2300	1.25				
371	103	3.83	2250	1.40				
176	215	16.22	2640	1.25	YR YRF	47	112M-2	48 48
196	195	14.56	2600	1.35				
228	168	12.54	2540	1.50				
242	158	11.79	2510	1.55				
282	136	10.15	2440	1.70				
315	121	9.07	2390	1.80				
357	107	8.01	2320	1.90				
369	104	7.76	2250	1.55				
411	93	6.96	2200	1.70				
477	80	6.00	2130	1.95				
507	75	5.64	2100	2.1				
589	65	4.85	2020	2.3				
660	58	4.34	1970	2.5				
746	51	3.83	1910	2.8				
255	150	5.56	6630	1.50	YRX YRXF	87	112M-4	71 76
280	137	5.07	6470	1.85				
316	121	4.50	6260	2.4				
375	102	3.78	5960	3.0				
351	109	4.04	4670	1.30	YRX YRXF	77	112M-4	55 58
383	100	3.70	4560	1.55				
437	87	3.25	4410	2.1				
461	83	3.08	4350	2.3				
527	73	2.70	4190	3.0				
585	65	2.43	4070	3.3				
667	57	2.13	3920	3.5				
755	51	1.88	3780	3.7				
852	45	1.67	3650	3.9				
998	38	1.42	3480	4.1				
444	86	3.20	2870	1.15	YRX YRXF	67	112M-4	47 51
492	78	2.89	2810	1.35				



技术参数

Technical Data

P ₁ = 4.0kW								
NA rpm	M ₂ Nm	i	Fr ₂ MAX[N]	f _s	Type	Gear unit	Motor size	 Kg
559	68	2.54	2730	1.75				
592	65	2.40	2690	1.90				
695	55	2.04	2580	2.4	YRX	67	112M-4	47
765	50	1.86	2520	2.5	YRXF	67	112M-4	51
883	43	1.61	2420	2.6				
1015	38	1.40	2330	2.8				
538	71	2.64	1670	0.95				
599	64	2.37	1780	1.10				
696	55	2.04	1910	1.25	YRX	57	112M-4	44
740	52	1.92	1940	1.35	YRXF	57	112M-4	46
859	44	1.65	1900	1.55				
962	40	1.48	1840	1.70				
1090	35	1.30	1790	1.80				
P ₁ = 5.5kW								
2.2	22200	656	120000	0.80				
2.5	19400	579	120000	0.95				
2.8	17000	503	120000	1.05				
3.3	14500	432	120000	1.25	YR	167 YR97	132S-4	780
3.8	12700	376	120000	1.40	YRF	167 YR97	132S-4	790
4.3	11300	335	120000	1.60				
4.7	10200	303	120000	1.75				
5.1	9360	279	120000	1.90				
3.1	15700	462	41200	0.85				
3.4	14600	426	55400	0.90				
3.9	12600	368	63500	1.05				
4.4	11100	326	66000	1.15	YR	147 YR87	132S-4	475
5.1	9520	280	68500	1.35	YRF	147 YR87	132S-4	480
5.8	8400	247	69900	1.55				
6.7	7250	214	71100	1.80				
7.6	6410	189	71900	2.0				
3.1	17000	229.71	120000	1.05				
3.8	13800	186.93	120000	1.30				
4.6	11300	153.07	120000	1.60	YR	167	160M2-8	700
5.1	10400	139.98	120000	1.75	YRF	167	160M2-8	700
5.8	9010	121.81	120000	2.0				
4.4	12100	163.31	64400	1.10				
4.8	10900	146.91	66500	1.20	YR	147	160M2-8	445
5.9	8870	119.86	69300	1.45	YRF	147	160M2-8	455
6.5	8090	109.31	70200	1.60				
5.9	8930	163.31	69200	1.45				
6.5	8040	146.91	70300	1.60	YR	147	132M2-6	440
8.0	6560	119.86	71700	2.0	YRF	147	132M2-6	450



技术参数

Technical Data

P ₁ = 5.5kW								
NA rpm	M ₂ Nm	i	Fr ₂ MAX[N]	f _s	Type	Gear unit	Motor size	 Kg
8.8	5980	109.31	72200	2.2	YR	147	132M2-6	440
10	5180	94.60	72800	2.5	YRF	147	132M2-6	450
12	4570	83.47	73200	2.9				
5.5	9480	128.18	44400	0.85				
6.2	8410	113.72	52200	0.95	YR	137	160M2-8	315
6.9	7630	103.20	54200	1.05	YRF	137	160M2-8	340
8.0	6560	88.70	56100	1.20				
5.5	9540	174.40	43300	0.85				
6.1	8550	156.31	51600	0.95				
6.8	7720	141.12	54000	1.05	YR	137	132M2-6	310
7.5	7010	128.18	55300	1.15	YRF	137	132M2-6	335
8.4	6220	113.72	56700	1.30				
9.3	5650	103.20	57600	1.40				
6.4	8180	222.60	53000	1.00				
7.6	6920	188.45	55500	1.15	YR	137	132S-4	295
8.2	6410	174.40	56400	1.25	YRF	137	132S-4	320
9.2	5740	156.31	57400	1.40				
10	5180	141.12	58200	1.55				
11	4710	128.18	58800	1.70				
13	4180	113.72	59300	1.90				
14	3790	103.20	59700	2.1				
16	3260	88.70	60200	2.5				
18	2970	80.91	60400	2.7	YR	137	132S-4	295
19	2700	73.49	60500	3.0	YRF	137	132S-4	320
22	2390	65.20	60700	3.3				
24	2170	59.17	60900	3.7				
28	1870	50.86	61000	4.3				
11	4690	127.68	27100	0.90				
12	4250	115.63	29800	1.00				
14	3770	102.53	32100	1.15				
15	3400	92.70	33500	1.25				
18	2890	78.57	33500	1.50	YR	107	132S-4	195
20	2680	72.88	32900	1.60	YRF	107	132S-4	205
22	2410	65.60	32100	1.80				
24	2180	59.41	31300	1.95				
27	1930	52.68	30300	2.2				
30	1750	47.63	29500	2.5				
35	1480	40.37	28200	2.9				
17	3050	83.15	17600	1.00				
20	2650	72.17	21800	1.15				
22	2390	65.21	24600	1.25	YR	97	132S-4	140
24	2200	59.92	24200	1.35	YRF	97	132S-4	155
27	1950	53.21	23600	1.55				
30	1750	47.58	23000	1.70				



技术参数

Technical Data

P ₁ = 5.5kW								
NA rpm	M ₂ Nm	i	Fr ₂ MAX[N]	f _s	Structure	Gear unit	Motor size	 Kg
33	1570	42.78	22500	1.90				
39	1360	37.13	21700	2.2	YR	97	132S-4	140
43	1220	33.25	21100	2.4	YRF	97	132S-4	155
52	1010	27.58	20100	2.6				
45	1180	32.05	20900	2.2				
53	1000	27.19	20000	2.6				
57	920	25.03	19600	3.1	YR	97	132S-4	135
64	820	22.37	19000	3.3	YRF	97	132S-4	155
71	740	20.14	18400	3.5				
78	670	18.24	17900	3.7				
88	595	16.17	17300	4.0				
30	1750	47.58	15400	0.90				
34	1530	41.74	17000	1.00	YR	87	132S-4	97
39	1350	36.84	17200	1.15	YRF	87	132S-4	105
44	1200	32.66	16700	1.30				
51	1020	27.88	16100	1.45				
51	1020	27.84	16100	1.50				
61	860	23.40	15500	1.80				
66	790	21.51	15200	1.90				
75	700	19.10	14700	2.1				
84	625	17.08	14300	2.2				
93	565	15.35	13900	2.4	YR	87	132S-4	96
107	490	13.33	13400	2.6	YRF	87	132S-4	105
120	440	11.93	13000	2.8				
144	365	9.90	12300	3.3				
156	335	9.14	12200	3.6				
174	300	8.22	11800	3.8				
200	260	7.13	11300	4.1				
76	690	18.80	9240	1.15	YR	77	132S-4	71
80	655	17.82	9400	1.20	YRF	77	132S-4	77
92	575	15.60	9150	1.30				
102	515	14.05	8950	1.40				
116	455	12.33	8690	1.50				
131	400	10.88	8440	1.65				
148	355	9.64	8190	1.80				
166	315	8.59	8080	2.0	YR	77	132S-4	71
185	285	7.74	7860	2.2	YRF	77	132S-4	77
211	250	6.79	7580	2.3				
239	220	5.99	7320	2.5				
269	195	5.31	7070	2.6				
91	580	15.79	6610	0.95				
96	550	14.91	6900	1.00	YR	67	132S-4	64
113	465	12.70	6810	1.10	YRF	67	132S-4	67
124	425	11.54	6690	1.20				



技术参数

Technical Data

P ₁ = 5.5kW								
NA rpm	M ₂ Nm	i	Fr ₂ MAX[N]	f _s	Structure	Gear unit	Motor size	 Kg
143	365	10.00	6500	1.30				
164	320	8.70	6310	1.40				
183	285	7.79	6180	1.35				
194	270	7.36	6100	1.35	YR	67	132S-4	64
228	230	6.27	5860	1.45	YRF	67	132S-4	67
251	210	5.70	5720	1.50				
290	181	4.93	5510	1.60				
333	158	4.29	5310	1.70				
331	159	8.70	5300	2.8				
369	142	7.79	5160	2.7				
391	134	7.36	5080	2.8	YR	67	132S1-2	64
460	114	6.27	4860	2.9	YRF	67	132S1-2	67
506	104	5.70	4730	3.0				
584	90	4.93	4540	3.2				
671	78	4.29	4350	3.5				
97	545	14.77	1730	0.80				
103	510	13.95	2070	0.85	YR	57	132S-4	58
120	435	11.88	2900	0.95	YRF	57	132S-4	61
132	395	10.79	3270	1.00				
153	345	9.35	3240	1.10				
179	295	7.97	3220	1.20				
190	275	7.53	3200	1.25	YR	57	132S-4	58
223	235	6.41	3120	1.40	YRF	57	132S-4	61
246	215	5.82	3080	1.50				
283	185	5.05	3000	1.65				
326	161	4.39	2920	1.75				
308	171	9.35	2930	2.2				
361	145	7.97	2850	2.4				
383	137	7.53	2820	2.6	YR	57	132S-4	58
449	117	6.41	2720	2.9	YRF	57	132S-4	61
494	106	5.82	2660	3.0				
571	92	5.05	2560	3.3				
656	80	4.39	2470	3.5				
295	178	4.85	1870	0.85	YR	47	132S-4	53
330	159	4.34	2110	0.90	YRF	47	132S-4	53
373	141	3.83	2080	1.00				
230	230	12.54	1730	1.10				
244	215	11.79	1910	1.15				
284	185	10.15	2250	1.25				
318	165	9.07	2220	1.35	YR	47	Y132S1-2	53
359	146	8.01	2170	1.40	YRF	47	Y132S1-2	53
480	109	6.00	2000	1.45				
511	103	5.64	1970	1.50				
593	89	4.85	1920	1.70				



技术参数

Technical Data

P ₁ = 5.5kW								
NA rpm	M ₂ Nm	i	Fr ₂ MAX[N]	f _s	Structure	Gear unit	Motor size	 Kg
664	79	4.34	1870	1.85	YR	47	132S1-2	53
752	70	3.83	1820	2.1	YRF	47	132S1-2	53
216	245	6.63	10500	1.90				
255	205	5.61	9980	2.2	YRX	107	132S-4	135
276	191	5.19	9760	3.7	YRXF	107	132S-4	150
307	171	4.65	9460	4.1				
247	215	5.79	8380	1.95				
291	180	4.91	8010	2.2				
316	166	4.52	7820	3.6				
354	149	4.04	7580	4.0				
393	134	3.64	7350	4.5				
434	121	3.30	7140	4.9	YRX	97	132S-4	105
489	107	2.92	6890	5.5	YRXF	97	132S-4	110
541	97	2.64	6690	6.1				
638	82	2.24	6360	7.2				
731	72	1.96	6110	7.9				
874	60	1.64	5780	8.4				
1010	52	1.42	5530	8.8				
318	165	4.50	6040	1.75				
378	139	3.78	5770	2.2				
411	128	3.48	5640	3.2	YRX	87	132S-4	77
463	113	3.09	5460	3.6	YRXF	87	132S-4	82
518	101	2.76	5290	4.0				
576	91	2.48	5130	4.5				
664	79	2.15	4930	4.9				
440	119	3.25	4220	1.50				
464	113	3.08	4160	1.70				
530	99	2.70	4030	2.2				
589	89	2.43	3920	2.4	YRX	77	132S-4	62
671	78	2.13	3780	2.6	YRXF	77	132S-4	65
761	69	1.88	3660	2.7				
858	61	1.67	3540	2.8				
1005	52	1.42	3380	3.0				
563	93	2.54	2550	1.25				
596	88	2.40	2520	1.40				
700	75	2.04	2430	1.80	YRX	67	132S-4	52
770	68	1.86	2380	1.85	YRXF	67	132S-4	56
889	59	1.61	2300	1.95				
1020	51	1.40	2220	2.0				
700	75	2.04	665	0.90				
745	71	1.92	755	1.00				
866	61	1.65	940	1.15	YRX	57	132S-4	49
969	54	1.48	1020	1.25	YRXF	57	132S-4	51
1095	48	1.30	1160	1.30				



技术参数

Technical Data

P ₁ = 7.5kW								
NA rpm	M ₂ Nm	i	Fr ₂ MAX[N]	f _s	Structure	Gear unit	Motor size	 Kg
2.8	23400	503	120000	0.75				
3.3	19900	432	120000	0.90				
3.8	17500	376	120000	1.05	YR	167 YR97	132M-4	800
4.3	15600	335	120000	1.15	YRF	167 YR97	132M-4	810
4.7	14000	303	120000	1.30				
5.1	12900	279	120000	1.40				
4.4	15200	326	47300	0.85				
5.1	13000	280	62600	1.00				
5.8	11500	247	65400	1.15	YR	147 YR87	132M-4	495
6.7	9940	214	67900	1.30	YRF	147 YR87	132M-4	500
7.6	8790	189	69400	1.50				
9.0	7390	159	71000	1.75				
3.1	22900	229.71	120000	0.80				
3.9	18600	186.93	120000	0.95				
4.7	15200	153.07	120000	1.20	YR	167	160L-8	730
5.1	13900	139.98	120000	1.30	YRF	167	160L-8	740
5.9	12100	121.81	120000	1.50				
4.2	17100	229.71	120000	1.05	YR	167	160M-6	700
5.1	13900	186.93	120000	1.30	YRF	167	160M-6	700
6.3	11400	153.07	120000	1.60				
6.9	10400	139.98	120000	1.70				
7.9	9090	121.81	120000	2.0				
8.9	8020	107.49	120000	2.2	YR	167	160M-6	700
10	6950	93.19	120000	2.6	YRF	167	160M-6	700
12	6190	82.91	120000	2.9				
13	5500	73.70	120000	3.3				
14	5030	67.40	120000	3.6				
4.4	16200	163.31	32800	0.80				
4.9	14600	146.91	55100	0.90	YR	147	160L-8	480
6.0	11900	119.86	64700	1.10	YRF	147	160L-8	490
6.6	10900	109.31	66500	1.20				
5.9	12200	163.31	64200	1.05	YR	147	160M-6	445
6.5	11000	146.91	66300	1.20	YRF	147	160M-6	455
8.0	8940	119.86	69200	1.45				
8.8	8150	109.31	70100	1.60	YR	147	160M-6	445
10	7060	94.60	71300	1.85	YRF	147	160M-6	455
12	6230	83.47	72000	2.1				
7.6	9440	188.45	45300	0.85				
8.2	8730	174.40	50800	0.90	YR	137	160M-6	305
9.2	7830	156.31	53700	1.00	YRF	137	160M-6	325
10	7070	141.12	55200	1.15				



技术参数

Technical Data

P ₁ = 7.5kW								
N _A rpm	M ₂ Nm	i	Fr ₂ MAX[N]	f _s	Structure	Gear unit	Motor size	 Kg
11	6420	128.18	56400	1.25				
13	5700	113.72	57500	1.40				
14	5170	103.20	58200	1.55				
16	4440	88.70	59100	1.80				
18	4050	80.91	59500	1.95	YR	137	132M-4	305
19	3680	73.49	59800	2.2	YRF	137	132M-4	325
22	3270	65.20	60100	2.5				
24	2960	59.17	60400	2.7				
28	2550	50.86	60600	3.1				
15	4640	92.70	27500	0.95				
18	3940	78.57	31300	1.10				
20	3650	72.88	31300	1.20				
22	3290	65.60	30600	1.30				
24	2980	59.41	30000	1.45	YR	107	132M-4	215
27	2640	52.68	29200	1.65	YRF	107	132M-4	225
30	2390	47.63	28500	1.80				
35	2020	40.37	27300	2.1				
41	1770	35.26	26400	2.4				
48	1480	29.49	25200	2.9				
46	1540	30.77	25500	2.8	YR	107	132M-4	210
52	1380	27.58	24700	3.1	YRF	107	132M-4	215
57	1250	24.90	24100	3.5				
63	1130	22.62	23400	3.8				
24	3000	59.92	19700	1.00				
27	2670	53.21	22200	1.15	YR	97	132M-4	160
30	2380	47.58	21800	1.25	YRF	97	132M-4	175
33	2140	42.78	21300	1.40				
39	1860	37.13	20700	1.60				
43	1670	33.25	20200	1.75	YR	97	132M-4	160
52	1380	27.58	19400	1.95	YRF	97	132M-4	175
45	1610	32.05	20000	1.60				
53	1360	27.19	19300	1.90				
57	1250	25.03	18900	2.3	YR	97	132M-4	155
64	1120	22.37	18400	2.4	YRF	97	132M-4	175
71	1010	20.14	17900	2.6				
78	910	18.24	17500	2.7				
39	1840	36.84	11500	0.85	YR	87	132M-4	120
44	1640	32.66	15700	0.95	YRF	87	132M-4	125
51	1400	27.88	15200	1.05				
51	1390	27.84	15200	1.10				
61	1170	23.40	14700	1.30	YR	87	132M-4	120
66	1080	21.51	14500	1.40	YRF	87	132M-4	125
75	960	19.10	14100	1.50				



技术参数

Technical Data

P ₁ = 7.5kW								
NA rpm	M ₂ Nm	i	Fr ₂ MAX[N]	f _s	Structure	Gear unit	Motor size	 Kg
84	860	17.08	13700	1.65				
93	770	15.35	12500	1.75				
107	670	13.33	12900	1.90				
120	600	11.93	12600	2.1				
144	495	9.90	12000	2.4	YR	87	132M-4	120
156	460	9.14	11900	2.6	YRF	87	132M-4	125
174	410	8.22	11600	2.8				
200	355	7.13	11100	3.0				
224	320	6.39	10800	3.2				
270	265	5.30	10200	3.4				
76	940	18.80	5310	0.85				
80	890	17.82	5720	0.85				
92	780	15.60	6610	0.95				
102	705	14.05	7180	1.00				
116	615	12.33	7750	1.10				
131	545	10.88	8010	1.20	YR	77	132M-4	92
148	485	9.64	7810	1.30	YRF	77	132M-4	98
166	430	8.59	7620	1.45				
185	390	7.74	7590	1.55				
211	340	6.79	7340	1.70				
239	300	5.99	7110	1.80				
269	265	5.31	6890	1.90				
113	635	12.70	4240	0.80				
124	580	11.54	4860	0.85				
143	500	10.00	5620	0.95				
164	435	8.70	5930	1.00				
183	390	7.79	5500	0.95	YR	67	132M-4	87
194	370	7.36	5720	1.00	YRF	67	132M-4	90
228	315	6.27	5600	1.05				
251	285	5.70	5480	1.10				
290	245	4.93	5300	1.15				
333	215	4.29	5130	1.25				
179	400	7.97	980	0.90				
190	375	7.53	1280	0.95				
223	320	6.41	2020	1.05	YR	57	132M-4	81
246	290	5.82	2380	1.10	YRF	57	132M-4	84
283	255	5.05	2760	1.20				
326	220	4.39	2710	1.25				
196	365	14.77	2580	1.20				
208	345	13.95	2780	1.25				
244	295	11.88	2780	1.40				
269	265	10.79	2750	1.45	YR	57	132S2-2	87
310	230	9.35	2710	1.60	YRF	57	132S2-2	90
364	197	7.97	2670	1.80				
385	186	7.53	2640	1.90				



技术参数

Technical Data

P ₁ = 7.5kW												
N _A rpm	M ₂ Nm	i	Fr ₂ MAX[N]	f _s	Structure	Gear unit	Motor size	 Kg				
452	158	6.41	2570	2.1	YR	57	132S2-2	87				
498	144	5.82	2520	2.2								
575	125	5.05	2440	2.5								
660	108	4.39	2370	2.6								
216	330	6.63	10100	1.40	YRX	107	132M-4	155				
255	280	5.61	9690	1.60								
276	260	5.19	9490	2.7	YRXF	107	132M-4	170				
307	235	4.65	9210	3.0								
340	210	4.20	8950	3.9								
247	290	5.79	8080	1.45	YRX	97	132M-4	125				
291	245	4.91	7750	1.60								
316	225	4.52	7580	2.6								
354	205	4.04	7360	2.9								
393	182	3.64	7160	3.3								
434	165	3.30	6960	3.6								
489	146	2.92	6730	4.1	YRXF	97	132M-4	130				
318	225	4.50	5760	1.30								
378	189	3.78	5530	1.60	YRX	87	132M-4	99				
411	174	3.48	5420	2.3								
463	155	3.09	5260	2.6								
518	138	2.76	5110	2.9								
576	124	2.48	4970	3.3								
664	108	2.15	4780	3.6								
741	97	1.93	4640	3.7								
894	80	1.60	4400	3.9								
1030	70	1.39	4230	4.2								
440	163	3.25	3820	1.10					YRX	77	132M-4	83
464	154	3.08	3890	1.25								
530	135	2.70	3820	1.60								
589	122	2.43	3730	1.75								
671	107	2.13	3620	1.85								
761	94	1.88	3510	2.0								
858	84	1.67	3400	2.1								
1005	71	1.42	3260	2.2								
563	127	2.54	1500	0.95	YRX	67	132M-4	75				
596	120	2.40	1610	1.00								
700	102	2.04	1810	1.30								
770	93	1.86	1930	1.35								
889	81	1.61	2060	1.40								
1020	70	1.40	2080	1.50								
563	127	2.54	1500	0.95					YRXF	67	132M-4	79
596	120	2.40	1610	1.00								



技术参数

Technical Data

P ₁ = 11 kW								
N _A rpm	M ₂ Nm	i	Fr ₂ MAX[N]	f _s	Structure	Gear unit	Motor size	 Kg
4.9	19600	295	120000	0.90				
5.3	18200	270	120000	1.00	YR	167 YR107	160M-4	860
6.3	15400	229	120000	1.15	YRF	167 YR107	160M-4	870
7.2	13400	200	120000	1.35				
8.5	11300	169	120000	1.60				
5.0	20000	291	120000	0.90	YR	167 YR107	160M-4	860
					YRF	167 R107	160M-4	860
4.3	22800	335	120000	0.80	YR	167 YR97	160M-4	820
4.8	20500	303	120000	0.90	YRF	167 YR97	160M-4	820
5.2	18900	279	120000	0.95				
5.8	16800	247	22800	0.75				
6.7	14500	214	56000	0.90	YR	147 YR87	160M-4	510
7.6	12900	189	63000	1.00	YRF	147 YR87	160M-4	520
9.1	10800	159	66600	1.20				
5.1	20500	186.93	120000	0.90				
6.3	16700	153.07	120000	1.05	YR	167	160L-6	730
6.9	15300	139.98	120000	1.20	YRF	167	160L-6	740
7.9	13300	121.81	120000	1.35				
6.3	16800	229.71	120000	1.05	YR	167	160M-4	700
7.7	13600	186.93	120000	1.30	YRF	167	160M-4	700
9.4	11200	153.07	120000	1.60				
10	10200	139.98	120000	1.75				
12	8890	121.81	120000	2.0	YR	167	160M-4	700
13	7840	107.49	120000	2.3	YRF	167	160M-4	700
15	6800	93.19	120000	2.7				
17	6050	82.91	120000	3.0				
6.5	16100	146.91	35400	0.80				
8.0	13100	119.86	62400	1.00	YR	147	160M-4	480
8.8	12000	109.31	64600	1.10	YRF	147	160M-4	490
10	10400	94.60	67300	1.25				
12	9130	83.47	69000	1.40				
8.8	11900	163.31	64700	1.10	YR	147	160M-4	445
9.8	10700	146.91	66700	1.20	YRF	147	160M-4	455
12	8740	119.86	69400	1.50				
13	7970	109.31	70300	1.65				
15	6900	94.60	71400	1.90				
17	6090	83.47	72100	2.1	YR	147	160M-4	445
20	5260	72.09	72800	2.5	YRF	147	160M-4	455
22	4890	66.99	73000	2.7				
24	4460	61.09	73300	2.9				
27	3860	52.87	73600	3.4				



技术参数

Technical Data

P ₁ = 11 kW								
NA rpm	M ₂ Nm	i	Fr ₂ MAX[N]	f _s	Structure	Gear unit	Motor size	 Kg
10	10300	141.12	23300	0.80				
11	9350	128.18	46900	0.85				
13	8300	113.72	52700	0.95				
14	7530	103.20	54400	1.05				
16	6470	88.70	56300	1.25				
18	5900	80.91	57200	1.35				
20	5360	73.49	57900	1.50	YR	137	160M-4	315
22	4760	65.20	58700	1.70	YRF	137	160M-4	340
24	4320	59.17	59200	1.85				
28	3710	50.86	59800	2.2				
32	3240	44.39	60200	2.5				
38	2750	37.65	60500	2.9				
44	2400	32.91	60700	3.3				
22	4790	65.60	23700	0.90				
24	4330	59.41	27600	1.00				
27	3840	52.68	27100	1.10				
30	3470	47.63	26600	1.25	YR	107	160M-4	230
36	2940	40.37	25700	1.45	YRF	107	160M-4	235
41	2570	35.26	25000	1.65				
49	2150	29.49	24000	2.0				
47	2240	30.77	24200	1.90				
52	2010	27.58	23600	2.1				
58	1820	24.90	23100	2.4	YR	107	160M-4	225
64	1650	22.62	22500	2.6	YRF	107	160M-4	230
72	1460	20.07	21800	2.9				
79	1330	18.21	21300	3.2				
34	3120	42.78	14500	0.95				
39	2710	37.13	18900	1.10				
43	2430	33.25	18600	1.20				
52	2010	27.58	18000	1.35				
58	1830	25.03	17700	1.55				
64	1630	22.37	17300	1.65				
71	1470	20.14	16900	1.80				
79	1330	18.24	16600	1.90	YR	97	160M-4	175
89	1180	16.17	16100	2.0	YRF	97	160M-4	190
98	1070	14.62	15700	2.2				
116	900	12.39	15100	2.4				
133	790	10.83	14600	2.7				
155	675	9.29	14300	3.0				
172	610	8.39	13900	3.3				
202	520	7.12	13200	3.9				
232	455	6.21	12700	4.2				
67	1570	21.51	13200	0.95	YR	87	160M-4	130
75	1390	19.10	13000	1.05	YRF	87	160M-4	140
84	1250	17.08	12800	1.10				



技术参数

Technical Data

P ₁ = 11 kW								
NA rpm	M ₂ Nm	i	Fr ₂ MAX[N]	f _s	Structure	Gear unit	Motor size	 Kg
94	1120	15.35	12500	1.20				
108	970	13.33	12200	1.30				
121	870	11.93	11900	1.40				
145	720	9.90	11400	1.65	YR	87	160M-4	130
158	665	9.14	11500	1.80	YRF	87	160M-4	140
175	600	8.22	11200	1.95				
202	520	7.13	10800	2.1				
225	465	6.39	10400	2.2				
272	385	5.30	9910	2.4				
132	795	10.88	4250	0.85	YR	77	160M-4	105
149	705	9.64	5000	0.90	YRF	77	160M-4	110
186	565	7.74	4630	1.10				
212	495	6.79	5250	1.15	YR	77	160M-4	105
240	435	5.99	5720	1.25	YRF	77	160M-4	110
271	390	5.31	6090	1.30				
277	380	5.19	9000	1.85				
310	340	4.65	8770	2.1				
343	305	4.20	8560	2.7	YRX	107	160M-4	170
377	280	3.81	8360	3.0	YRXF	107	160M-4	185
425	245	3.38	8100	3.4				
469	225	3.07	7900	3.7				
545	193	2.64	7580	4.3				
318	330	4.52	7150	1.80				
356	295	4.04	6970	2.0				
396	265	3.64	6800	2.2				
437	240	3.30	6640	2.5				
493	215	2.92	6440	2.8	YRX	97	160M-4	135
545	193	2.64	6280	3.1	YRXF	97	160M-4	145
643	163	2.24	6000	3.6				
736	143	1.96	5790	4.0				
880	119	1.64	5500	4.2				
1015	103	1.42	5280	4.4				
414	255	3.48	5030	1.60				
466	225	3.09	4910	1.80	YRX	87	160M-4	110
522	200	2.76	4790	2.0	YRXF	87	160M-4	115
580	181	2.48	4680	2.2				
669	157	2.15	4530	2.5				
747	141	1.93	4400	2.5	YRX	87	160M-4	110
900	117	1.60	4200	2.7	YRXF	87	160M-4	115
1035	102	1.39	4050	2.9				
593	177	2.43	1890	1.20				
676	155	2.13	2140	1.30	YRX	77	160M-4	96
766	137	1.88	2330	1.35	YRXF	77	160M-4	99
864	122	1.67	2460	1.40				
1010	104	1.42	2580	1.50				



技术参数

Technical Data

P ₁ = 15kW									
NA rpm	M ₂ Nm	i	Fr ₂ MAX[N]	f _s	Structure	Gear unit	Motor size	Kg	
6.4	20800	229	120000	0.85	YR	167 YR107	160L-4	900	
7.3	18200	200	120000	1.00				910	
8.6	15300	169	120000	1.20				910	
6.4	20900	227	120000	0.85	YR	167 YR107	160L-4	900	
7.4	18200	198	120000	1.00				900	
6.3	22600	153.07	120000	0.80	YR	167	180L-6	770	
6.9	20700	139.98	120000	0.85				770	
8.0	18000	121.81	120000	1.00				770	
9.0	15900	107.49	120000	1.15				770	
6.4	22500	229.71	120000	0.80	YR	167	160L-4	730	
7.8	18300	186.93	120000	1.00				740	
9.5	15000	153.07	120000	1.20	YR	167	160L-4	730	
10	13700	139.98	120000	1.30				740	
12	12000	121.81	120000	1.50				740	
14	10500	107.49	120000	1.70				740	
16	9140	93.19	120000	1.95				740	
18	8130	82.91	120000	2.2				740	
20	7230	73.70	120000	2.5				740	
22	6610	67.40	120000	2.7				740	
8.9	16100	109.31	34400	0.80				YR	147
10	14000	94.60	60600	0.95	530				
12	12300	83.47	64000	1.05	530				
13	10600	72.09	66800	1.20	530				
14	9890	66.99	67900	1.30	530				
8.9	16000	163.31	36200	0.80	YR	147	160L-4	480	
9.9	14400	146.91	57400	0.90				490	
12	11800	119.86	65000	1.10				490	
13	10700	109.31	66700	1.20				490	
15	9280	94.60	68800	1.40	YR	147	160L-4	480	
17	8190	83.47	70100	1.60				490	
20	7070	72.09	71300	1.85				490	
22	6570	66.99	71700	2.0				490	
24	5990	61.09	72200	2.2				490	
28	5190	52.87	72800	2.5				490	
31	4580	46.65	73200	2.8				490	
14	10100	103.20	30700	0.80				YR	137
16	8700	88.70	51000	0.90	380				
18	7940	80.91	53500	1.00	380				
20	7210	73.49	55000	1.10	380				
22	6400	65.20	56400	1.25	YR	137	160L-4	355	
25	5800	59.17	57300	1.40				380	
29	4990	50.86	58400	1.60				380	



技术参数

Technical Data

P ₁ = 15kW								
NA rpm	M ₂ Nm	i	Fr ₂ MAX[N]	f _s	Structure	Gear unit	Motor size	 Kg
33	4360	44.39	59100	1.85				
39	3690	37.65	59800	2.2	YR	137	160L-4	355
44	3230	32.91	60200	2.5	YRF	137	160L-4	380
52	2730	27.83	60500	2.8				
31	4670	47.63	24500	0.90				
36	3960	40.37	23900	1.10	YR	107	160L-4	270
41	3460	35.26	23400	1.25	YRF	107	160L-4	275
50	2890	29.49	22600	1.50				
47	3020	30.77	22800	1.40				
53	2710	27.58	22400	1.60				
59	2440	24.90	21900	1.75				
65	2220	22.62	21400	1.95	YR	107	160L-4	265
73	1970	20.07	20900	2.2	YRF	107	160L-4	270
80	1790	18.21	20400	2.4				
93	1540	15.65	19700	2.8				
107	1340	13.66	19000	3.2				
53	2710	27.58	16500	1.00	YR	97	160L-4	215
					YRF	97	160L-4	230
58	2460	25.03	16300	1.15				
65	2200	22.37	16100	1.25				
72	1980	20.14	15800	1.30				
80	1790	18.24	15600	1.40				
90	1590	16.17	15200	1.50				
100	1430	14.62	14900	1.60	YR	97	160L-4	210
118	1220	12.39	14400	1.80	YRF	97	160L-4	230
135	1060	10.83	14000	1.95				
157	910	9.29	13800	2.2				
174	820	8.39	13400	2.5				
205	700	7.12	12800	2.9				
235	610	6.21	12400	3.1				
85	1680	17.08	11600	0.85				
95	1510	15.35	11500	0.90	YR	87	160L-4	170
110	1310	13.33	11300	1.00	YRF	87	160L-4	175
122	1170	11.93	11100	1.05				
147	970	9.90	10700	1.20				
160	900	9.14	11000	1.35				
178	810	8.22	10700	1.45	YR	87	160L-4	170
205	700	7.13	10300	1.55	YRF	87	160L-4	175
229	625	6.39	10100	1.65				
275	520	5.30	9600	1.75				
281	510	5.19	8440	1.35				
314	455	4.65	8260	1.50	YRX	107	160L-4	210
348	410	4.20	8100	2.0	YRXF	107	160L-4	225
383	375	3.81	7930	2.2				



技术参数

Technical Data

P ₁ = 15kW								
NA rpm	M ₂ Nm	i	Fr ₂ MAX[N]	f _s	Structure	Gear unit	Motor size	 Kg
431	330	3.38	7720	2.5				
475	300	3.07	7540	2.8				
553	260	2.64	7260	3.2				
634	225	2.30	7010	3.7	YRX	107	160L-4	210
747	192	1.95	6710	4.0	YRXF	107	160L-4	225
855	168	1.71	6470	4.2				
1010	142	1.44	6170	4.6				
323	445	4.52	6660	1.35				
361	395	4.04	6530	1.50				
401	355	3.64	6400	1.65				
443	325	3.30	6270	1.85				
499	285	2.92	6110	2.1	YRX	97	160L-4	180
552	260	2.64	5970	2.3	YRXF	97	160L-4	185
652	220	2.24	5730	2.7				
746	192	1.96	5550	3.0				
892	161	1.64	5290	3.2				
1030	139	1.42	5090	3.3				
420	340	3.48	4260	1.20				
473	305	3.09	4510	1.35				
529	270	2.76	4430	1.50	YRX	87	160L-4	150
588	245	2.48	4350	1.65	YRXF	87	160L-4	155
678	210	2.15	4230	1.80				
757	189	1.93	4130	1.90	YRX	87	160L-4	150
913	157	1.60	3960	2.0	YRXF	87	160L-4	155
1050	137	1.39	3840	2.1				
P ₁ = 18.5kW								
7.8	22500	186.93	120000	0.80				
9.6	18500	153.07	120000	1.00	YR	167	180M-4	750
10	16900	139.98	120000	1.05	YRF	167	180M-4	760
12	14700	121.81	120000	1.25				
14	13000	107.49	120000	1.40				
16	11200	93.19	120000	1.60				
18	10000	82.91	120000	1.80	YR	167	180M-4	750
20	8890	73.70	120000	2.0	YRF	167	180M-4	760
22	8130	67.40	120000	2.2				
25	7070	58.65	120000	2.6				
12	14500	119.86	56900	0.90	YR	147	180M-4	500
13	13200	109.31	62300	1.00	YRF	147	180M-4	510
15	11400	94.60	65600	1.15				
18	10100	83.47	67700	1.30				
20	8690	72.09	69500	1.50				
22	8080	66.99	70200	1.60				
24	7370	61.09	71000	1.75				



技术参数

Technical Data

P ₁ = 18.5kW												
NA rpm	M ₂ Nm	i	Fr ₂ MAX[N]	f _s	Structure	Gear unit	Motor size	 Kg				
28	6380	52.87	71900	2.0	YR	147	180M-4	500				
31	5630	46.65	72500	2.3								
36	4860	40.29	73000	2.7								
18	9760	80.91	39000	0.80	YR	137	180M-4	375				
20	8860	73.49	50200	0.90								
22	7860	65.20	53700	1.00								
25	7140	59.17	55100	1.10								
29	6130	50.86	56800	1.30	YR	137	180M-4	375				
33	5350	44.39	58000	1.50								
39	4540	37.65	58900	1.75								
45	3970	32.91	59500	2.0								
53	3360	27.83	60100	2.3								
50	3570	29.57	59900	2.2	YR	137	180M-4	365				
61	2910	24.12	60400	2.8								
67	2650	22.00	60600	3.0								
77	2300	19.04	60800	3.5								
87	2030	16.80	60900	4.0								
36	4870	40.37	20200	0.90					YR	107	180M-4	295
42	4250	35.26	22000	1.00								
50	3560	29.49	21500	1.20								
59	3000	24.90	20900	1.45	YR	107	180M-4	285				
65	2730	22.62	20600	1.60								
73	2420	20.07	20100	1.80								
80	2200	18.21	19700	1.95								
94	1890	15.65	19100	2.3								
107	1650	13.66	18500	2.6								
126	1400	11.59	17800	3.1								
145	1220	10.13	17200	3.5								
186	950	7.86	16300	3.1								
220	800	6.66	15600	3.7								
73	2430	20.14	14900	1.05					YR	97	180M-4	235
80	2200	18.24	14700	1.15								
91	1950	16.17	14500	1.25								
100	1760	14.62	14200	1.30								
118	1490	12.39	13800	1.45								
135	1310	10.83	13500	1.60								
158	1120	9.29	13400	1.80								
175	1010	8.39	13100	2.0								
206	860	7.12	12600	2.3								
236	750	6.21	12100	2.5								
282	625	5.20	11600	2.8								
326	545	4.50	11100	3.0								



技术参数

Technical Data

P ₁ = 18.5kW								
N _A rpm	M ₂ Nm	i	Fr ₂ MAX[N]	f _s	Structure	Gear unit	Motor size	 Kg
349	505	4.20	7710	1.65				
384	460	3.81	7580	1.80	YRX	107	180M-4	230
433	410	3.38	7400	2.0	YRXF	107	180M-4	250
477	370	3.07	7250	2.2				
555	320	2.64	7010	2.6				
636	280	2.30	6780	3.0	YRX	107	180M-4	230
750	235	1.95	6510	3.3	YRXF	107	180M-4	250
858	205	1.71	6290	3.4				
1015	174	1.44	6020	3.7				
402	440	3.64	6060	1.35				
444	400	3.30	5960	1.50				
501	355	2.92	5830	1.70				
554	320	2.64	5710	1.85	YRX	97	180M-4	200
654	270	2.24	5510	2.2	YRXF	97	180M-4	210
749	235	1.96	5350	2.4				
895	197	1.64	5120	2.6				
1035	171	1.42	4940	2.7				
531	335	2.76	3040	1.20				
590	300	2.48	3340	1.35				
680	260	2.15	3630	1.50	YRX	87	180M-4	175
760	235	1.93	3820	1.55	YRXF	87	180M-4	180
916	193	1.60	3770	1.65				
1055	168	1.39	3670	1.75				
P ₁ = 22kW								
9.6	22000	153.07	120000	0.80	YR	167	180L-4	770
10	20100	139.98	120000	0.90	YRF	167	180L-4	770
12	17500	121.81	120000	1.05				
14	15400	107.49	120000	1.15				
16	13400	93.19	120000	1.35				
18	11900	82.91	120000	1.50				
20	10600	73.70	120000	1.70	YR	167	180L-4	770
22	9670	67.40	120000	1.85	YRF	167	180L-4	770
25	8410	58.65	120000	2.1				
28	7420	51.76	120000	2.4				
33	6430	44.87	120000	2.8				
13	15700	109.31	41300	0.85				
15	13600	94.60	61500	0.95				
18	12000	83.47	64600	1.10				
20	10300	72.09	67300	1.25	YR	147	180L-4	520
22	9610	66.99	68300	1.35	YRF	147	180L-4	530
24	8760	61.09	69400	1.50				
28	7580	52.87	70800	1.70				
31	6690	46.65	71600	1.95				



技术参数

Technical Data

P ₁ = 22kW								
NA rpm	M ₂ Nm	i	Fr ₂ MAX[N]	f _s	Structure	Gear unit	Motor size	 Kg
36	5780	40.29	72400	2.3	YRX	147	180L-4	520
41	5110	35.64	72900	2.5				
49	4300	29.95	73400	3.0				
22	9350	65.20	46900	0.85	YR	137	180L-4	390
25	8480	59.17	51900	0.95				
29	7290	50.86	54800	1.10				
33	6370	44.39	56500	1.25				
39	5400	37.65	57900	1.50	YR	137	180L-4	390
45	4720	32.91	58700	1.70				
53	3990	27.83	59500	1.90				
50	4240	29.57	59300	1.85	YR	137	180L-4	380
61	3460	24.12	60000	2.3				
67	3150	22.00	60200	2.5				
77	2730	19.04	60500	2.9				
87	2410	16.80	60700	3.3	YR	137	180L-4	380
101	2080	14.51	60900	3.9				
114	1840	12.83	61000	4.4				
42	5060	35.26	7280	0.85	YR	107	180L-4	305
50	4230	29.49	20400	1.00				
59	3570	24.90	20000	1.20	YR	107	180L-4	300
65	3240	22.62	19700	1.35				
73	2880	20.07	19300	1.50				
80	2610	18.21	19000	1.65	YR	107	180L-4	300
94	2240	15.65	18500	1.90				
107	1960	13.66	18000	2.2				
126	1660	11.59	17300	2.6				
145	1450	10.13	16800	3.0				
171	1230	8.56	16100	3.5				
186	1130	7.86	16100	2.6				
220	960	6.66	15400	3.1				
252	840	5.82	14800	3.6				
73	2890	20.14	14000	0.90				
80	2620	18.24	13900	0.95				
91	2320	16.17	13700	1.05				
100	2100	14.62	13600	1.10				
118	1780	12.39	13200	1.25	YR	97	180L-4	245
135	1550	10.83	13000	1.35				
158	1330	9.29	13100	1.50				
175	1200	8.39	12800	1.70				
206	1020	7.12	12300	1.95				
236	890	6.21	11900	2.1				
282	745	5.20	11400	2.4				
326	645	4.50	10900	2.5				



技术参数

Technical Data

P ₁ = 22kW								
Na rpm	M ₂ Nm	i	Fr ₂ MAX[N]	f _s	Structure	Gear unit	Motor size	 Kg
148	1420	9.90	9640	0.85				
160	1310	9.14	10100	0.90				
178	1180	8.22	9960	1.00	YR	87	180L-4	205
205	1020	7.13	9700	1.05	YRF	87	180L-4	215
229	920	6.39	9490	1.10				
276	760	5.30	9110	1.20				
349	600	4.20	7330	1.40				
384	545	3.81	7230	1.50	YRX	107	180L-4	245
433	485	3.38	7090	1.70	YRXF	107	180L-4	260
477	440	3.07	6960	1.90				
555	380	2.64	6760	2.2				
636	330	2.30	6560	2.5				
750	280	1.95	6320	2.7	YRX	107	180L-4	245
858	245	1.71	6120	2.9	YRXF	107	180L-4	260
1015	205	1.44	5870	3.1				
402	520	3.64	5720	1.15				
444	475	3.30	5650	1.25				
501	420	2.92	5560	1.40				
554	380	2.64	5460	1.55	YRX	97	180L-4	215
654	320	2.24	5300	1.85	YRXF	97	180L-4	220
749	280	1.96	5160	2.0				
895	235	1.64	4960	2.2				
1035	205	1.42	4790	2.2				
531	395	2.76	1270	1.00				
590	355	2.48	1710	1.15				
680	310	2.15	2160	1.25	YRX	87	180L-4	190
760	275	1.93	2450	1.30	YRXF	87	180L-4	195
916	230	1.60	2750	1.35				
1055	200	1.39	3030	1.45				
P ₁ = 30kW								
14	20900	107.49	120000	0.85	YRX	167	200L-4	850
16	18200	93.19	120000	1.00	YRXF	167	200L-4	860
18	16200	82.91	120000	1.10				
20	14400	73.70	120000	1.25				
22	13100	67.40	120000	1.35				
25	11400	58.65	120000	1.55				
28	10100	51.76	120000	1.80	YRX	167	200L-4	850
33	8740	44.87	120000	2.1	YRXF	167	200L-4	860
37	7780	39.92	120000	2.3				
43	6710	34.41	120000	2.7				
53	5450	27.96	120000	3.3				
62	4620	23.71	120000	3.9				



技术参数

Technical Data

P ₁ = 30kW								
NA rpm	M ₂ Nm	i	Fr ₂ MAX[N]	f _s	Structure	Gear unit	Motor size	 Kg
18	16300	83.47	32400	0.80				
20	14000	72.09	60400	0.95	YR	147	200L-4	600
22	13100	66.99	62500	1.00	YRF	147	200L-4	610
24	11900	61.09	64700	1.10				
28	10300	52.87	67300	1.25				
32	9090	46.65	69000	1.45				
36	7850	40.29	70500	1.65	YR	147	200L-4	600
41	6950	35.64	71400	1.85	YRF	147	200L-4	610
49	5840	29.95	72300	2.2				
61	4710	24.19	73100	2.5				
72	3980	20.44	73600	3.0	YR	147	200L-4	590
82	3510	18.04	73800	3.0	YRF	147	200L-4	600
94	3050	15.64	74000	4.3				
29	9910	50.86	35800	0.80				
33	8650	44.39	51200	0.90	YR	137	200L-4	475
39	7340	37.65	54700	1.10	YRF	137	200L-4	500
45	6410	32.91	56400	1.25				
53	5420	27.83	57900	1.40				
61	4700	24.12	58800	1.70	YR	137	200L-4	465
67	4290	22.00	59200	1.85	YRF	137	200L-4	490
77	3710	19.04	59800	2.2				
88	3270	16.80	60100	2.4				
101	2830	14.51	59500	2.8				
115	2500	12.83	58400	3.2	YR	137	200L-4	465
136	2100	10.79	56600	3.8	YRF	137	200L-4	490
194	1480	7.59	53300	3.5				
230	1240	6.38	51300	4.1				
73	3910	20.07	17600	1.10				
81	3550	18.21	17400	1.20				
94	3050	15.65	17100	1.40				
108	2660	13.66	16800	1.60				
127	2260	11.59	16300	1.90	YR	107	200L-4	385
145	1970	10.13	15900	2.2	YRF	107	200L-4	390
172	1670	8.56	15400	2.6				
187	1530	7.86	15500	1.95				
221	1300	6.66	14900	2.3				
252	1140	5.82	14400	2.6				
299	960	4.92	13700	3.0				
101	2850	14.62	12000	0.80				
119	2420	12.39	11900	0.90	YR	97	200L-4	330
136	2110	10.83	11800	1.00	YRF	97	200L-4	345
158	1810	9.29	12300	1.10				
175	1640	8.39	12100	1.25				



技术参数

Technical Data

P ₁ = 30kW								
NA rpm	M ₂ Nm	i	Fr ₂ MAX[N]	f _s	Structure	Gear unit	Motor size	 Kg
207	1390	7.12	11700	1.45				
237	1210	6.21	11400	1.55	YR	97	200L-4	330
283	1010	5.20	10900	1.75	YRF	97	200L-4	345
327	880	4.50	10500	1.85				
434	660	3.38	6370	1.25				
479	600	3.07	6310	1.40				
557	515	2.64	6180	1.60	YRX	107	200L-4	330
638	450	2.30	6050	1.85	YRXF	107	200L-4	345
752	380	1.95	5870	2.0				
860	335	1.71	5720	2.1				
1020	280	1.44	5520	2.3				
503	570	2.92	3120	1.05				
556	515	2.64	3560	1.15				
656	435	2.24	4050	1.35	YRX	97	200L-4	295
751	380	1.96	4450	1.50	YRXF	97	200L-4	305
898	320	1.64	4580	1.60				
1040	275	1.42	4450	1.65				
P ₁ = 37kW								
16	22400	93.19	120000	0.80				
18	19900	82.91	120000	0.90				
20	17700	73.70	120000	1.00				
22	16200	67.40	120000	1.10				
25	14100	58.65	120000	1.30	YR	167	225S-4	900
28	12400	51.76	120000	1.45	YRF	167	225S-4	900
33	10800	44.87	120000	1.65				
37	9600	39.92	120000	1.90				
43	8270	34.41	120000	2.2				
53	6720	27.96	120000	2.7				
48	7380	30.71	120000	1.35				
60	5900	24.57	120000	2.4	YR	167	225S-4	890
67	5250	21.85	120000	2.5	YRF	167	225S-4	900
77	4580	19.03	120000	3.5				
87	4080	16.98	120000	3.7				
22	16100	66.99	35000	0.80				
24	14700	61.09	54200	0.90				
28	12700	52.87	63200	1.00				
32	11200	46.65	65900	1.15				
36	9680	40.29	68200	1.35				
41	8570	35.64	69700	1.50	YR	147	225S-4	650
49	7200	29.95	71100	1.80	YRF	147	225S-4	660
61	5810	24.19	72400	2.1				
72	4910	20.44	73000	2.4				
82	4340	18.04	73400	2.4				
94	3760	15.64	73700	3.5				



技术参数

Technical Data

P ₁ = 30kW								
N _A rpm	M ₂ Nm	i	Fr ₂ MAX[N]	f _s	Structure	Gear unit	Motor size	 Kg
106	3340	13.91	73900	3.8	YR	147	225S-4	650
					RF	147	225S-4	660
39	9050	37.65	49400	0.90	YR	137	225S-4	520
45	7910	32.91	53600	1.00	YRF	137	225S-4	550
53	6690	27.83	55900	1.15				
61	5800	24.12	57300	1.40				
67	5290	22.00	58000	1.50	YR	137	225S-4	510
77	4580	19.04	57800	1.75	YRF	137	225S-4	540
88	4040	16.80	57300	2.0				
101	3490	14.51	56600	2.3				
115	3080	12.83	55800	2.6				
136	2590	10.79	54400	3.1	YR	137	225S-4	510
169	2090	8.71	52600	3.7	YRF	137	225S-4	540
194	1820	7.59	51900	2.8				
230	1530	6.38	50100	3.3				
285	1240	5.15	47800	3.7				
73	4820	20.07	16100	0.90				
81	4380	18.21	16100	1.00				
94	3760	15.65	15900	1.15				
108	3280	13.66	15700	1.30				
127	2790	11.59	15400	1.55				
145	2430	10.13	15100	1.75	YR	107	225S-4	435
172	2060	8.56	14700	2.1	YRF	107	225S-4	440
187	1890	7.86	15000	1.55				
221	1600	6.66	14400	1.85				
252	1400	5.82	14000	2.1				
299	1180	4.92	13400	2.5				
434	810	3.38	4470	1.00				
479	740	3.07	4950	1.10				
557	635	2.64	5530	1.30	YRX	107	225S-4	380
638	555	2.30	5610	1.50	YRXF	107	225S-4	395
752	470	1.95	5490	1.65				
860	410	1.71	5370	1.70				
1020	345	1.44	5220	1.85				

P ₁ = 45kW								
20	21500	73.70	120000	0.85				
22	19700	67.40	120000	0.90				
25	17100	58.65	120000	1.05				
28	15100	51.76	120000	1.20				
33	13100	44.87	120000	1.35	YR	167	225M-4	930
37	11700	39.92	120000	1.55	YRF	167	225M-4	930
43	10100	34.41	120000	1.80				
53	8170	27.96	120000	2.2				
62	6930	23.71	120000	2.6				



技术参数

Technical Data

P ₁ = 45kW								
NA rpm	M ₂ Nm	i	Fr ₂ MAX[N]	f _s	Structure	Gear unit	Motor size	 Kg
48	8980	30.71	120000	1.10				
60	7180	24.57	120000	1.95				
67	6390	21.85	120000	2.0	YR	167	225M-4	930
77	5560	19.03	120000	2.9	YRF	167	225M-4	930
87	4960	16.98	120000	3.0				
28	15500	52.87	44400	0.85				
32	13600	46.65	61300	0.95				
36	11800	40.29	65000	1.10	YR	147	225M-4	680
41	10400	35.64	67200	1.25	YRF	147	225M-4	690
49	8760	29.95	69400	1.50				
61	7070	24.19	71300	1.70				
72	5970	20.44	72200	2.0				
82	5270	18.04	72800	2.0				
94	4570	15.64	73200	2.8	YR	147	225M-4	670
106	4070	13.91	73500	3.1	YRF	147	225M-4	680
123	3510	11.99	73800	3.7				
203	2120	7.25	74300	4.1				
45	9620	32.91	41700	0.85	YR	137	225M-4	550
53	8130	27.83	51200	0.95	YRF	137	225M-4	580
61	7050	24.12	52400	1.15				
67	6430	22.00	52900	1.25	YR	137	225M-4	540
77	5570	19.04	53300	1.45	YRF	137	225M-4	570
88	4910	16.80	53400	1.65				
101	4240	14.51	53200	1.90				
115	3750	12.83	52800	2.1				
136	3150	10.79	51900	2.5	YR	137	225M-4	540
169	2550	8.71	50500	3.1	YRF	137	225M-4	570
194	2220	7.59	50200	2.3				
230	1860	6.38	48700	2.7				
285	1510	5.15	46700	3.1				
94	4580	15.65	14600	0.95				
108	3990	13.66	14600	1.10				
127	3390	11.59	14400	1.25				
145	2960	10.13	14300	1.45	YR	107	225M-4	460
172	2500	8.56	14000	1.70	YRF	107	225M-4	465
187	2300	7.86	14400	1.30				
221	1950	6.66	14000	1.50				
252	1700	5.82	13600	1.75				
299	1440	4.92	13100	2.0				
434	990	3.38	1360	0.85				
479	900	3.07	2080	0.90				
557	770	2.64	2970	1.10	YRX	107	225M-4	405
638	675	2.30	3640	1.25	YRXF	107	225M-4	420
752	570	1.95	4200	1.35				



技术参数

Technical Data

P₁ = 45kW								
-----------------------------	--	--	--	--	--	--	--	--

N _A rpm	M ₂ Nm	i	Fr ₂ MAX[N]	f _s	Structure	Gear unit	Motor size	Kg
860	500	1.71	4540	1.40	YRX	107	225M-4	405
1020	420	1.44	4880	1.55	YRXF	107	225M-4	420

P₁ = 55kW								
-----------------------------	--	--	--	--	--	--	--	--

25	20900	58.65	120000	0.85				
29	18400	51.76	120000	1.00				
33	16000	44.87	120000	1.15	YR	167	250M-4	1060
37	14200	39.92	120000	1.25	YRF	167	250M-4	1060
43	12300	34.41	120000	1.45				
53	9960	27.96	120000	1.80				
62	8440	23.71	120000	2.1				
60	8750	24.57	120000	1.60	YR	167	250M-4	1050
68	7780	21.85	120000	1.65	YRF	167	250M-4	1060
77	6780	19.03	120000	2.4				
87	6050	16.98	120000	2.5	YR	167	250M-4	1050
102	5150	14.48	120000	3.5	YRF	167	250M-4	1060
123	4270	11.99	120000	4.0				
32	16600	46.65	26600	0.80				
37	14300	40.29	58200	0.90	YR	147	250M-4	800
41	12700	35.64	63300	1.00	YRF	147	250M-4	810
49	10700	29.95	66800	1.20				
61	8610	24.19	69600	1.40				
72	7280	20.44	71100	1.65				
82	6420	18.04	71900	1.65	YR	147	250M-4	790
94	5570	15.64	72500	2.3	YRF	147	250M-4	800
106	4950	13.91	73000	2.5				
123	4270	11.99	73400	3.0				
151	3470	9.74	73800	3.8	YR	147	250M-4	790
203	2580	7.25	74200	3.4	YRF	147	250M-4	800
250	2100	5.89	72500	4.1				
77	6780	19.04	47800	1.20	YR	137	250M-4	660
88	5980	16.80	48500	1.35	YRF	137	250M-4	690
102	5170	14.51	48900	1.55				
115	4570	12.83	49000	1.75				
137	3840	10.79	48800	2.1				
169	3100	8.71	48000	2.5	YR	137	250M-4	660
194	2700	7.59	48100	1.90	YRF	137	250M-4	690
231	2270	6.38	46900	2.3				
286	1830	5.15	45200	2.5				

P₁ = 75kW								
-----------------------------	--	--	--	--	--	--	--	--

33	21700	44.87	120000	0.85	YR	167	280S-4	1190
37	19300	39.92	120000	0.95	YRF	167	280S-4	1190



技术参数

Technical Data

P ₁ = 75kW								
N _A rpm	M ₂ Nm	i	Fr ₂ MAX[N]	f _s	Structure	Gear unit	Motor size	 Kg
43	16700	34.41	120000	1.10	YR	167	280S-4	1190
53	13500	27.96	120000	1.35				
62	11500	23.71	120000	1.55				
60	11900	24.57	120000	1.20	YR	167	280S-4	1180
68	10600	21.85	120000	1.25				
78	9210	19.03	120000	1.75				
87	8220	16.98	120000	1.85	YR	167	280S-4	1180
102	7000	14.48	120000	2.6				
123	5800	11.99	116600	2.9				
145	4950	10.24	112800	3.4				
49	14500	29.95	56500	0.90	YR	147	280S-4	940
61	11700	24.19	65100	1.00				
72	9890	20.44	67900	1.20	YR	147	280S-4	930
82	8730	18.04	69500	1.20				
95	7570	15.64	70800	1.70				
106	6730	13.91	71600	1.85				
123	5800	11.99	72400	2.2	YR	147	280S-4	930
152	4710	9.74	73100	2.8				
179	4000	8.26	73500	3.3				
204	3510	7.25	73100	2.5				
251	2850	5.89	70100	3.0				
296	2420	5.00	67600	3.6				
P ₁ = 90kW								
37	23200	39.92	120000	0.80	YR	167	280M-4	1260
43	20000	34.41	120000	0.90				
53	16200	27.96	120000	1.10				
62	13800	23.71	120000	1.30				
60	14300	24.57	120000	1.00	YR	167	280M-4	1260
68	12700	21.85	120000	1.00				
78	11100	19.03	120000	1.45				
87	9860	16.98	120000	1.50	YR	167	280M-4	1260
102	8410	14.48	117300	2.1				
123	6960	11.99	113500	2.4				
145	5940	10.24	110100	2.9				
72	11900	20.44	64800	1.00	YR	147	280M-4	1000
82	10500	18.04	67100	1.00				
95	9080	15.64	69000	1.45				
106	8080	13.91	70200	1.55				



技术参数

Technical Data

P₁ = 90kW

N_A rpm	M₂ Nm	i	Fr_{2MAX}[N]	f_s	Structure	Gear unit	Motor size	 Kg
123	6960	11.99	71400	1.85				
152	5660	9.74	72500	2.3				
179	4800	8.26	73000	2.7	YR	147	280M-4	1000
204	4210	7.25	70900	2.1	YRF	147	280M-4	1010
251	3420	5.89	68300	2.5				
296	2900	5.00	66100	3.0				

P₁ = 110kW

53	19800	27.96	117100	0.90	YR	167	315S-4	1450
63	16800	23.71	116900	1.05	YRF	167	315S-4	1460
78	13500	19.03	115500	1.20				
87	12000	16.98	114300	1.25				
103	10200	14.48	112200	1.75				
124	8480	11.99	109300	2.0				
145	7240	10.24	106500	2.4				

P₁ = 132kW

63	20100	23.71	107900	0.90				
78	16200	19.03	108300	1.00				
87	14400	16.98	107800	1.05				
103	12300	14.48	106700	1.45				
124	10200	11.99	104700	1.65				
145	8690	10.24	102600	1.95				

P₁ = 160kW

103	14900	14.48	99700	1.20	YR	167	315M2-4	1540
124	12300	11.99	98900	1.40	YRF	167	315M2-4	1550
145	10500	10.24	97600	1.60				



安装尺寸

Mounting Dimensions

YR17...

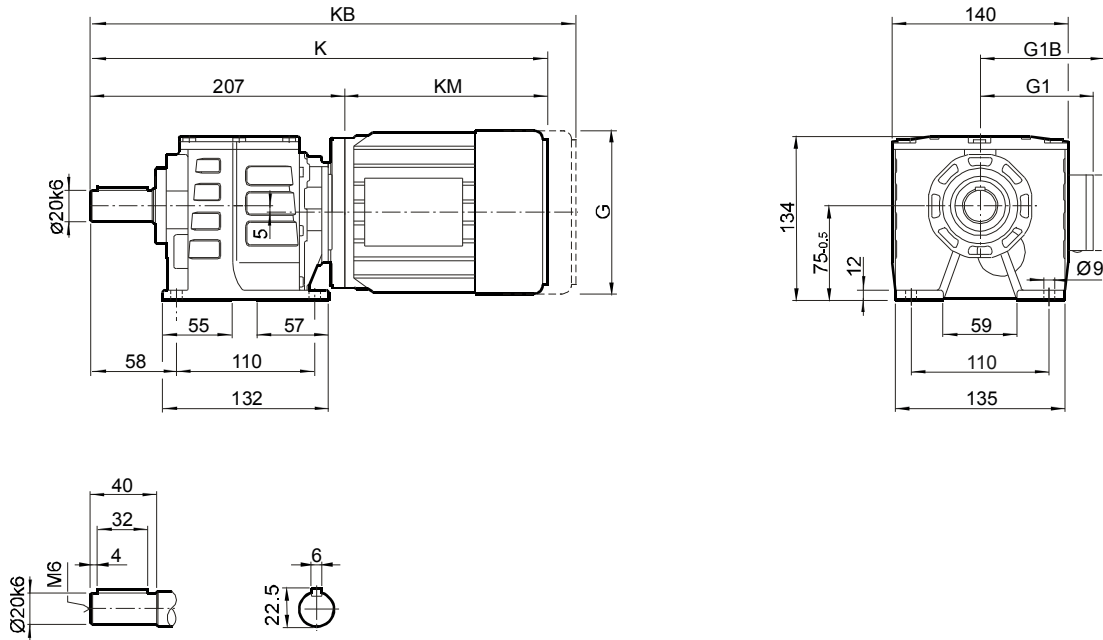

YR17F...

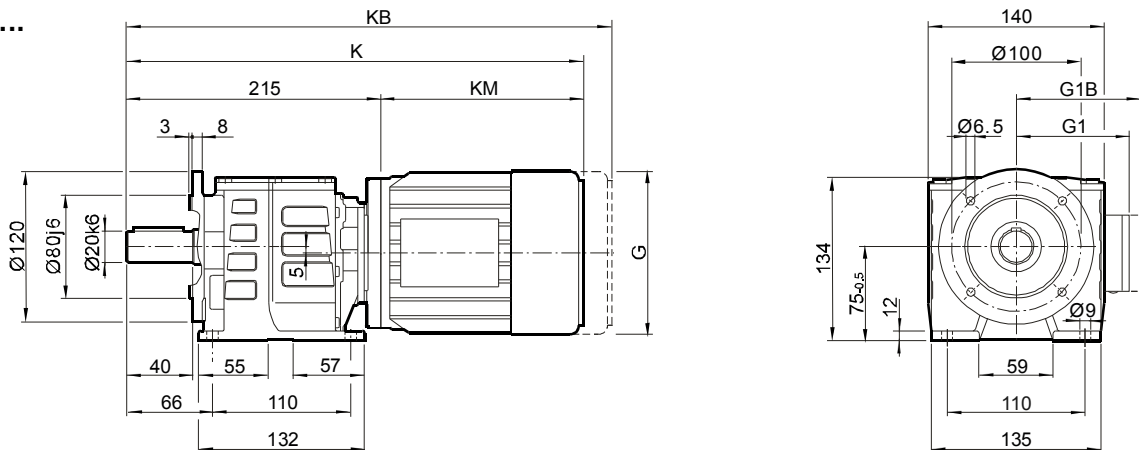

尺寸 Dimensions	电机规格 Motor frame									
	63	71	80							
G	132	145	145							
G1	99	122	122							
G1B	99	127	127							
K	356	371	421							
KB	411	435	485							
KM	149	164	214							

尺寸说明

以上尺寸为直联普通电机和制动电机尺寸；
G1B,KB为制动电机尺寸,其余为普通电机尺寸；
防爆电机, 辊道电机, 船用电机等须加过渡法兰, 见135页。

ATTENTION

Dimensions of general and brake motor shown in upon table,
the others like explosion, roller, or marine motor coupled by
adaptor, the dimensions on page 135.



安装尺寸

Mounting Dimensions

YRF17...

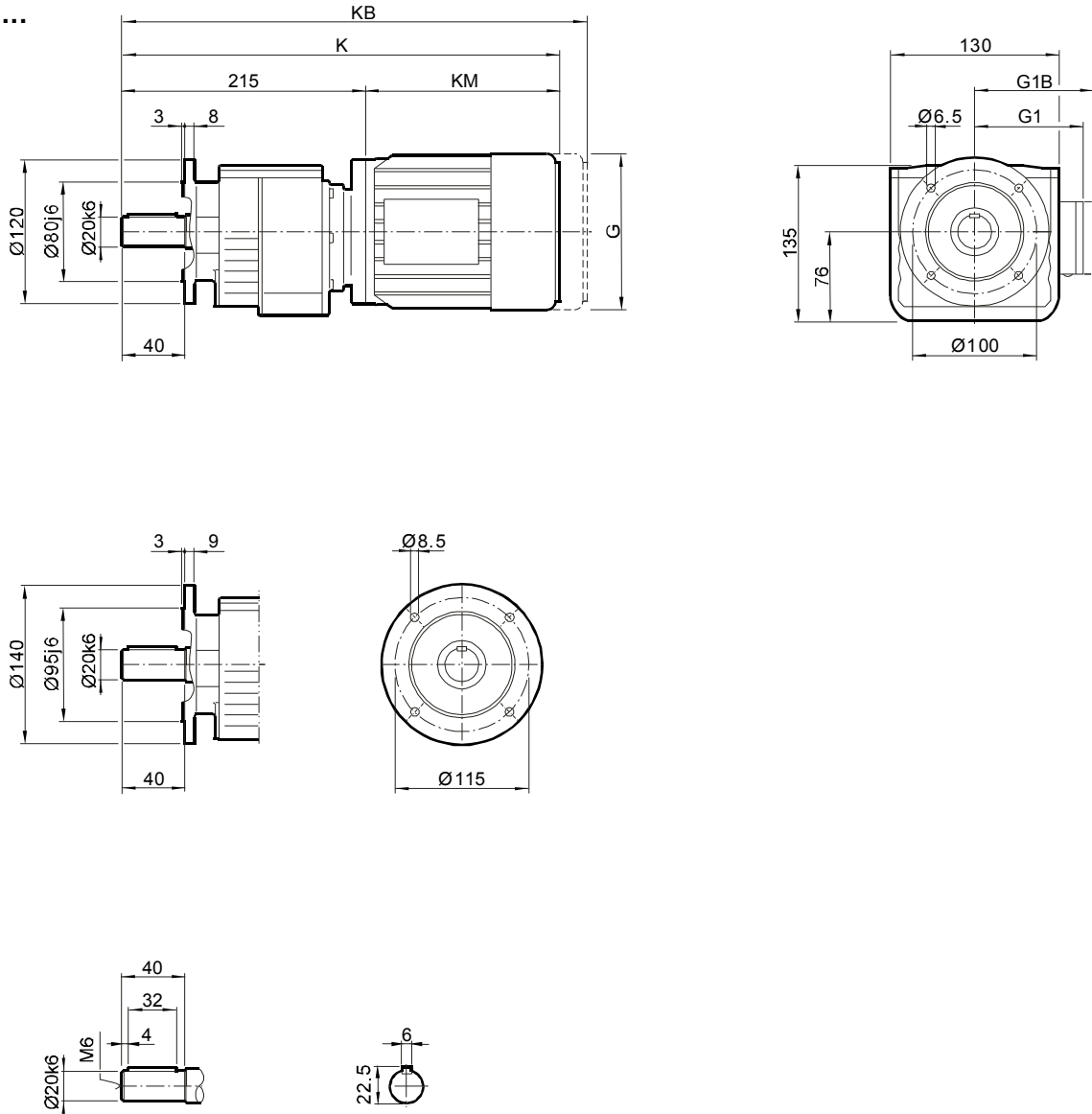

尺寸 Dimensions	电机规格 Motor frame									
	63	71	80							
G	132	145	145							
G1	99	122	122							
G1B	99	127	127							
K	364	379	429							
KB	419	443	493							
KM	149	164	214							

尺寸说明

以上尺寸为直联普通电机和制动电机尺寸；
G1B,KB为制动电机尺寸,其余为普通电机尺寸；
防爆电机，辊道电机，船用电机等须加过渡法兰，见135页。

ATTENTION

Dimensions of general and brake motor shown in upon table, the others like explosion, roller, or marine motor coupled by adaptor, the dimensions on page 135.



安装尺寸

Mounting Dimensions

YR27...

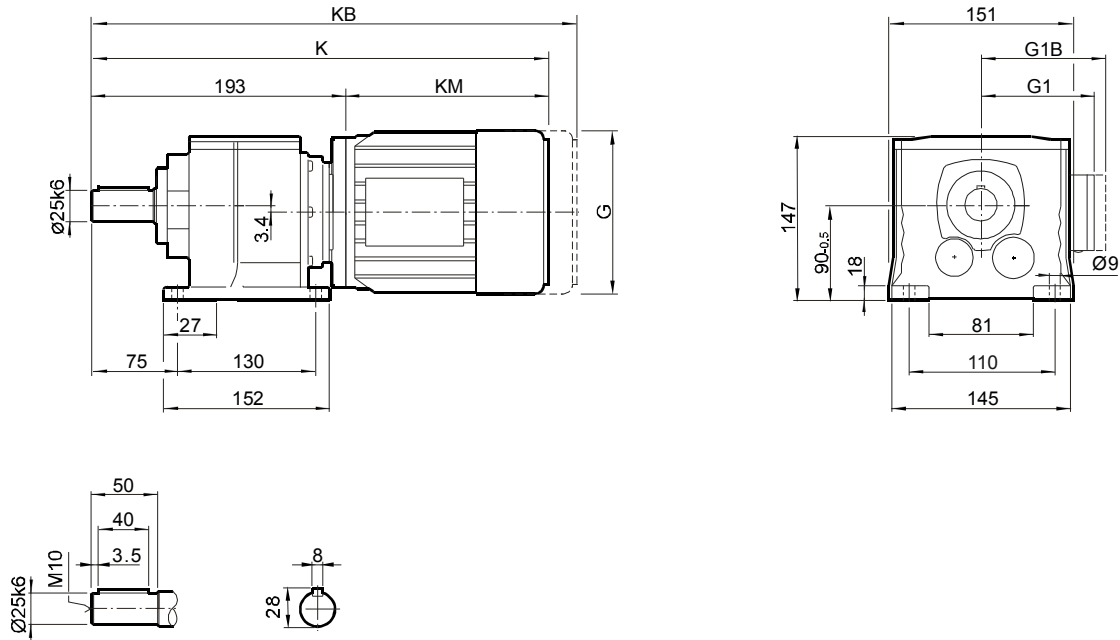

YR27F...

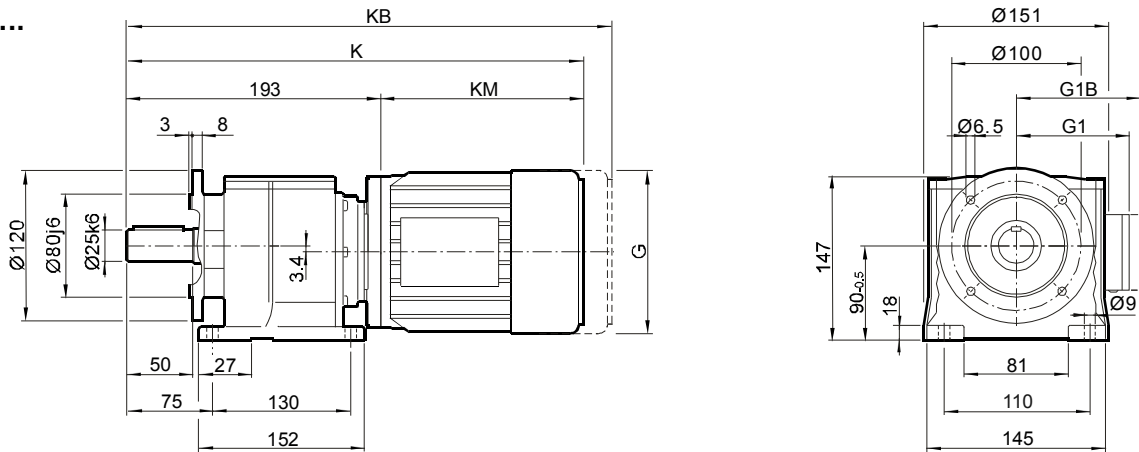

尺寸 Dimensions	电机规格 Motor frame									
	63	71	80	90	100M	100L				
G	132	145	145	197	197	197				
G1	99	122	122	154	166	166				
G1B	99	127	127	161	166	166				
K	384	399	449	469	521	551				
KB	439	463	513	554	606	636				
KM	191	206	256	276	328	358				

尺寸说明

以上尺寸为直联普通电机和制动电机尺寸；
G1B,KB为制动电机尺寸,其余为普通电机尺寸；
防爆电机, 辊道电机, 船用电机等须加过渡法兰, 见135页。

ATTENTION

Dimensions of general and brake motor shown in upon table,
the others like explosion, roller, or marine motor coupled by
adaptor, the dimensions on page 135.



安装尺寸

Mounting Dimensions

YRF27...

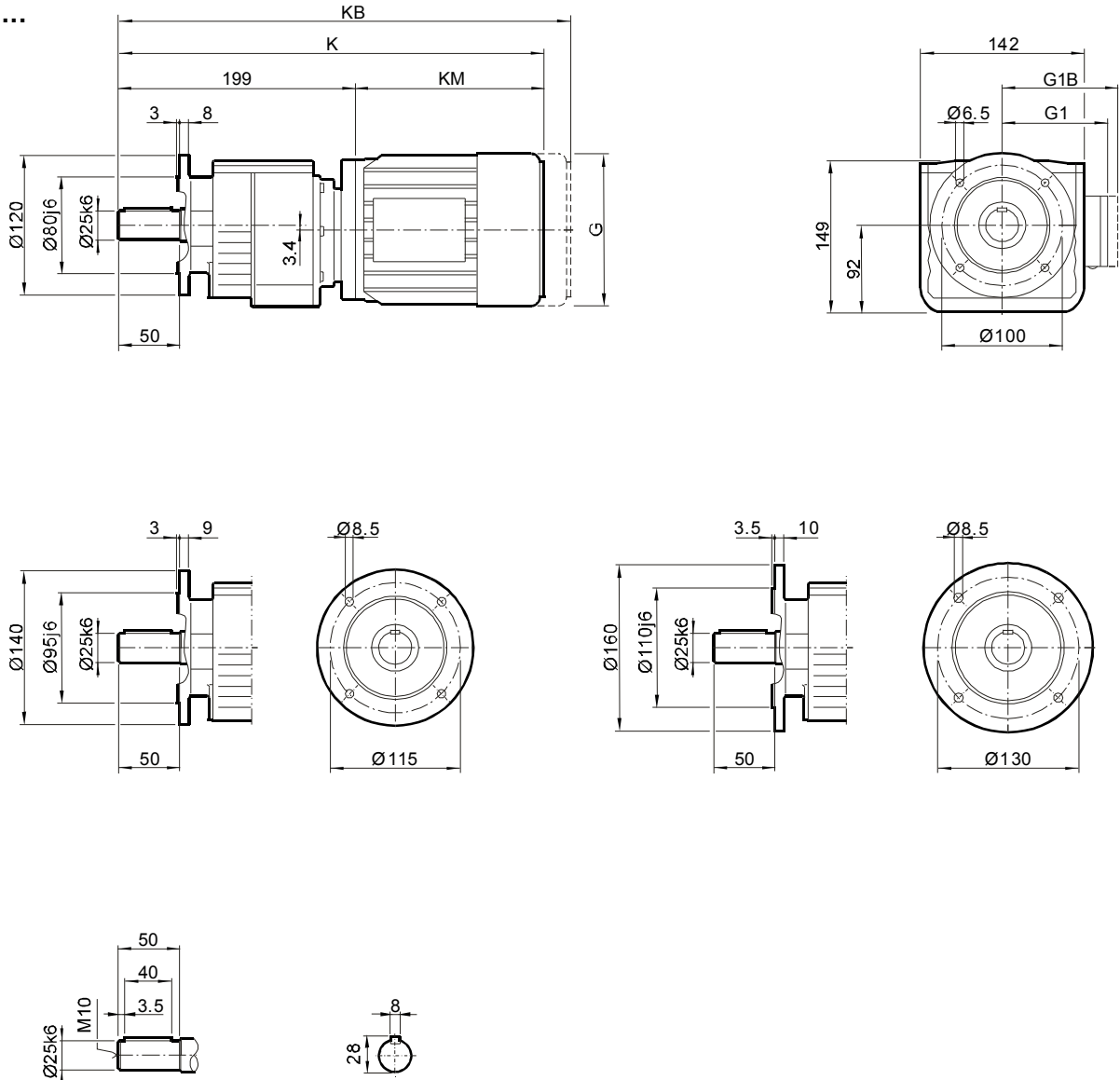

尺寸 Dimensions	电机规格 Motor frame										
	63	71	80	90	100M	100L					
G	132	145	145	197	197	197					
G1	99	122	122	154	166	166					
G1B	99	127	127	161	166	166					
K	390	405	455	475	527	557					
KB	445	469	519	560	612	642					
KM	191	206	256	276	328	358					

尺寸说明

以上尺寸为直联普通电机和制动电机尺寸；
G1B,KB为制动电机尺寸,其余为普通电机尺寸；
防爆电机，辊道电机，船用电机等须加过渡法兰，见135页。

ATTENTION

Dimensions of general and brake motor shown in upon table,
the others like explosion, roller, or marine motor coupled by
adaptor, the dimensions on page 135.



安装尺寸

Mounting Dimensions

YR37...

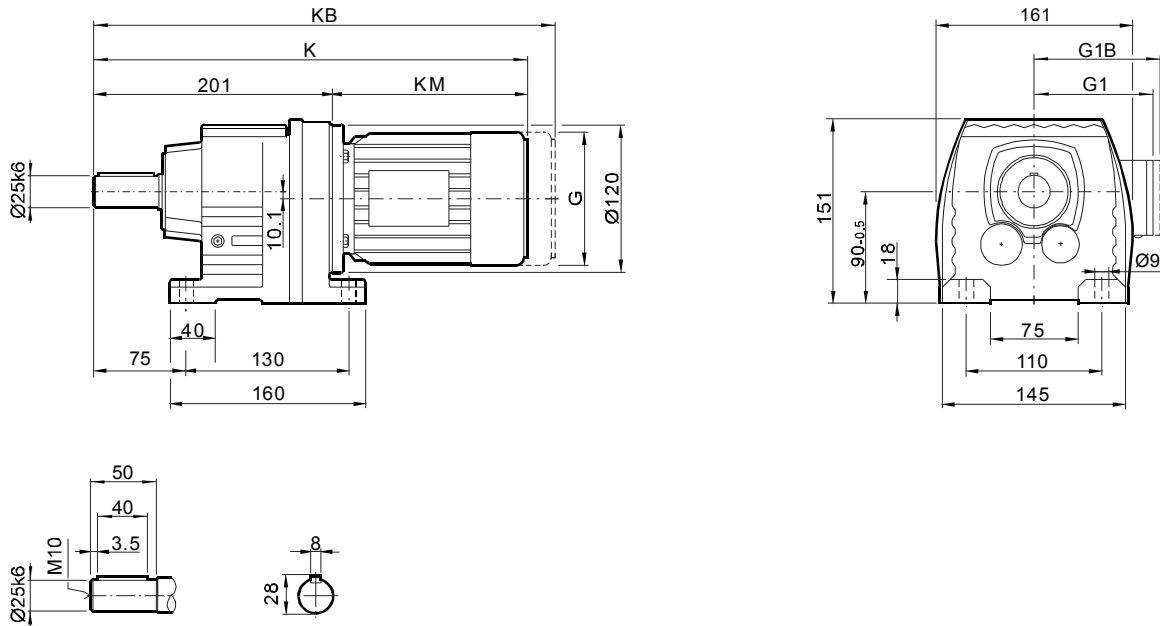

YR37F...

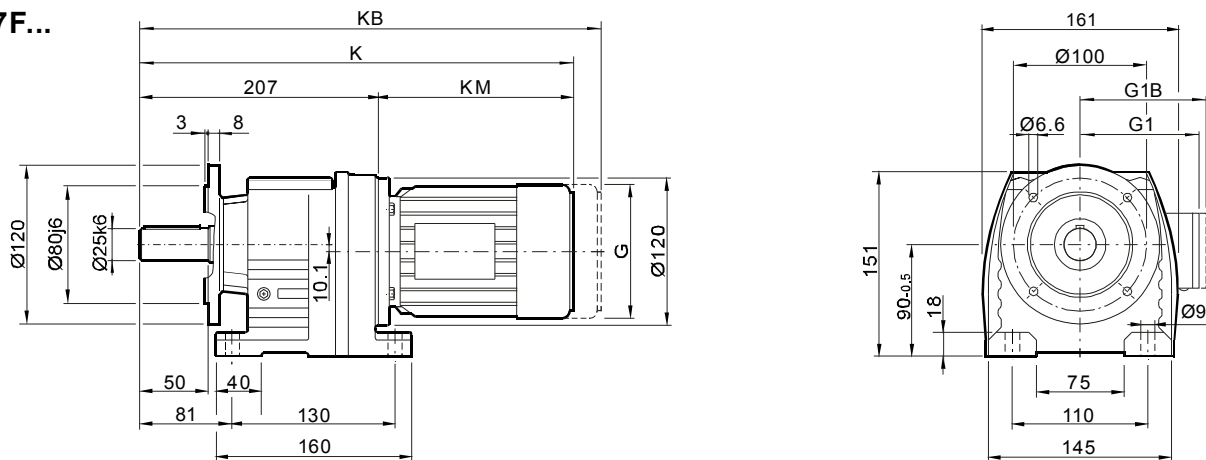

尺寸 Dimensions	电机规格 Motor frame									
	63	71	80	90	100M	100L				
G	132	145	145	197	197	197				
G1	99	122	122	154	166	166				
G1B	99	127	127	161	166	166				
K	392	407	457	477	529	559				
KB	447	471	521	562	614	644				
KM	191	206	256	276	328	358				

尺寸说明

以上尺寸为直联普通电机和制动电机尺寸；
G1B,KB为制动电机尺寸,其余为普通电机尺寸；
防爆电机, 辊道电机, 船用电机等须加过渡法兰, 见135页。

ATTENTION

Dimensions of general and brake motor shown in upon table,
the others like explosion, roller, or marine motor coupled by
adaptor, the dimensions on page 135.



安装尺寸

Mounting Dimensions

YRF37...

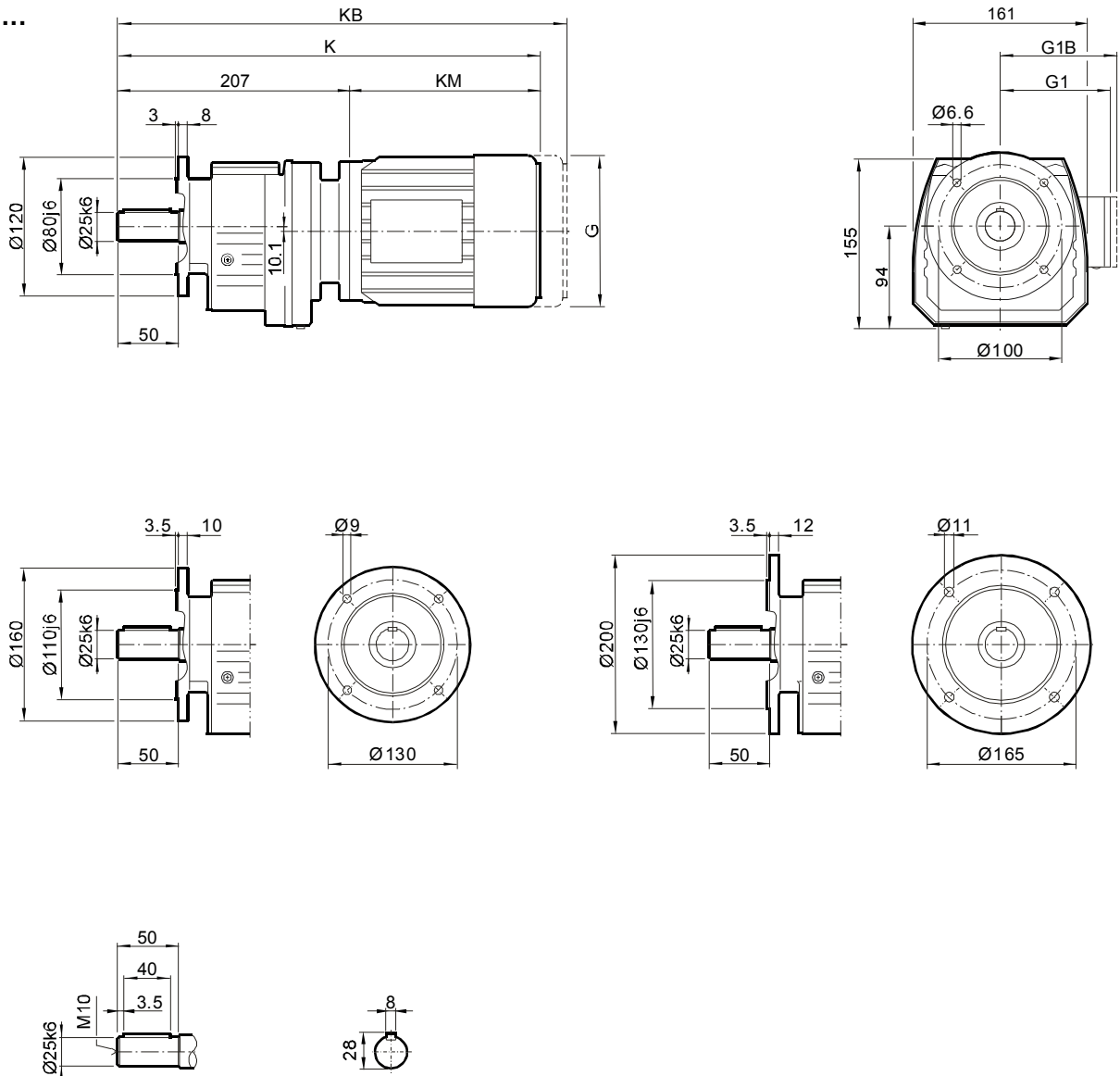

尺寸 Dimensions	电机规格 Motor frame									
	63	71	80	90	100M	100L				
G	132	145	145	197	197	197				
G1	99	122	122	154	166	166				
G1B	99	127	127	161	166	166				
K	398	413	463	483	535	565				
KB	453	477	527	568	620	650				
KM	191	206	256	276	328	358				

尺寸说明

以上尺寸为直联普通电机和制动电机尺寸；
G1B,KB为制动电机尺寸,其余为普通电机尺寸；
防爆电机，辊道电机，船用电机等须加过渡法兰，见135页。

ATTENTION

Dimensions of general and brake motor shown in upon table, the others like explosion, roller, or marine motor coupled by adaptor, the dimensions on page 135.



安装尺寸

Mounting Dimensions

YR47...

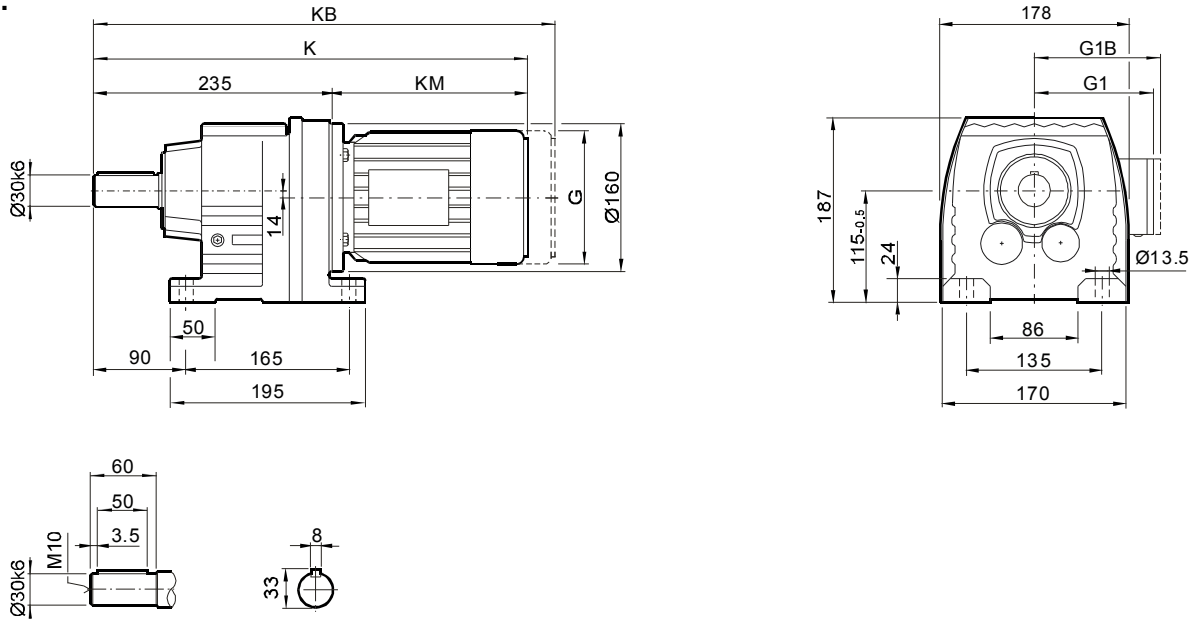

YR47F...

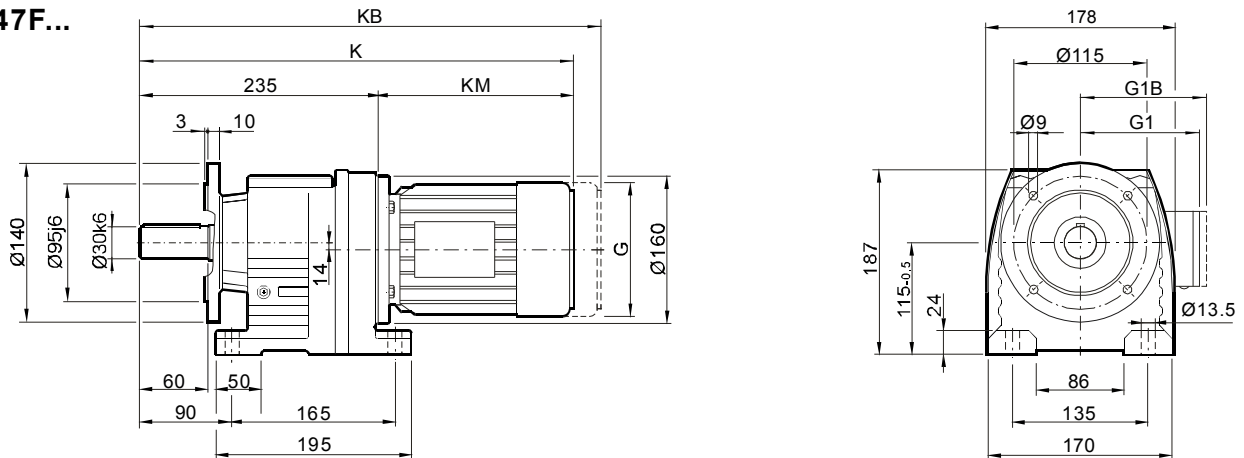

尺寸 Dimensions	电机规格 Motor frame									
	63	71	80	90	100M	100L	112M	132S	132M	
G	132	145	145	197	197	197	221	221	275	
G1	95	122	122	154	166	166	176	176	230	
G1B	95	127	127	161	166	166	182	182	230	
K	420	434	484	504	554	584	589	637	659	
KB	475	498	548	589	639	669	669	717	771	
KM	185	199	249	269	319	349	354	402	424	

尺寸说明

以上尺寸为直联普通电机和制动电机尺寸；
G1B,KB为制动电机尺寸,其余为普通电机尺寸；
防爆电机, 辊道电机, 船用电机等须加过渡法兰, 见135页。

ATTENTION

Dimensions of general and brake motor shown in upon table,
the others like explosion, roller, or marine motor coupled by
adaptor, the dimensions on page 135.



安装尺寸

Mounting Dimensions

YRF47...

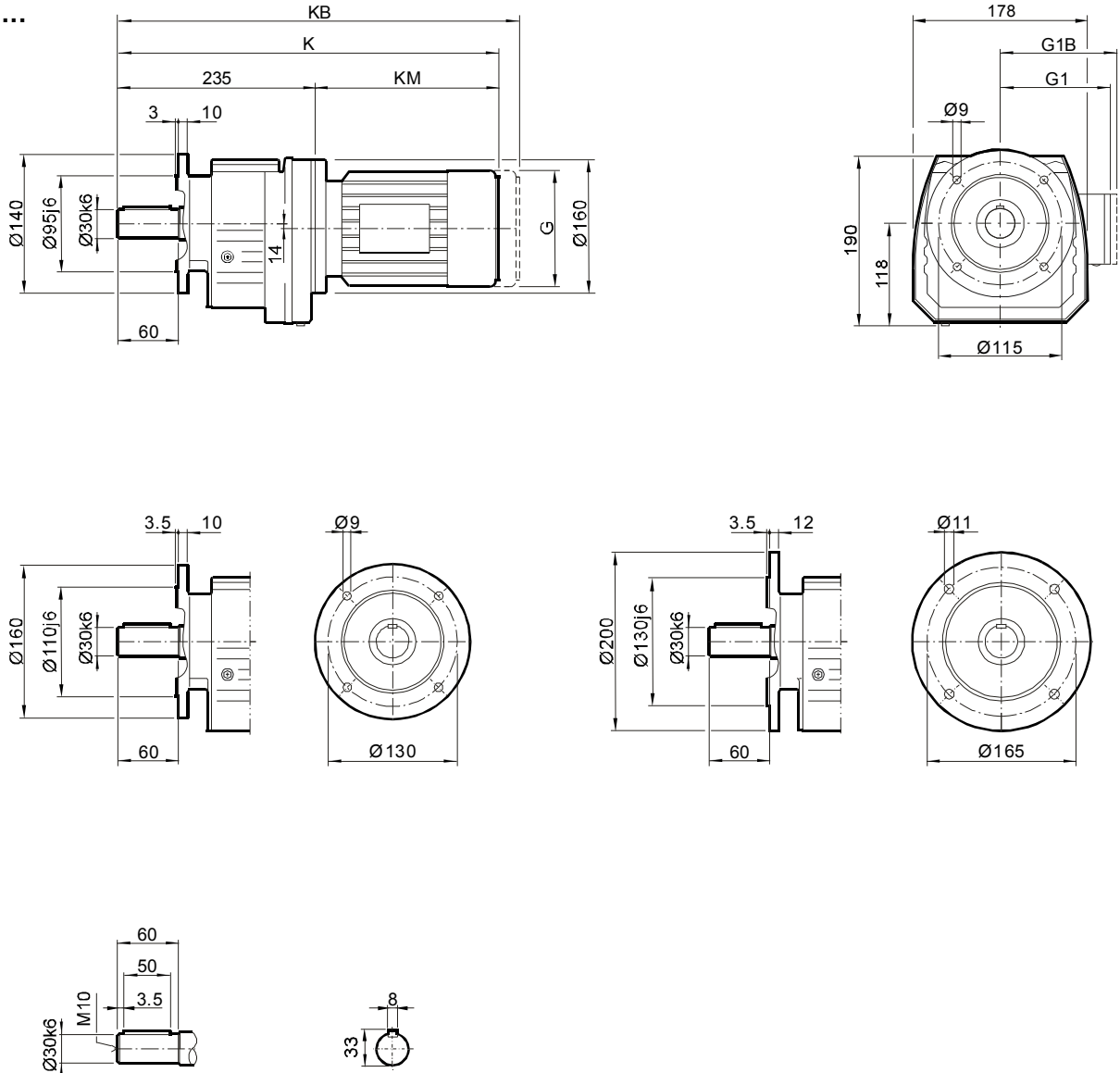

尺寸 Dimensions	电机规格 Motor frame									
	63	71	80	90	100M	100L	112M	132S	132M	
G	132	145	145	197	197	197	221	221	275	
G1	99	122	122	154	166	166	176	176	230	
G1B	99	127	127	161	166	166	182	182	230	
K	420	434	484	504	554	584	589	637	659	
KB	475	498	548	589	639	669	669	717	771	
KM	185	199	249	269	319	349	354	402	424	

尺寸说明

以上尺寸为直联普通电机和制动电机尺寸；
G1B,KB为制动电机尺寸,其余为普通电机尺寸；
防爆电机，辊道电机，船用电机等须加过渡法兰，见135页。

ATTENTION

Dimensions of general and brake motor shown in upon table,
the others like explosion, roller, or marine motor coupled by
adaptor, the dimensions on page 135.



安装尺寸

Mounting Dimensions

YR57...

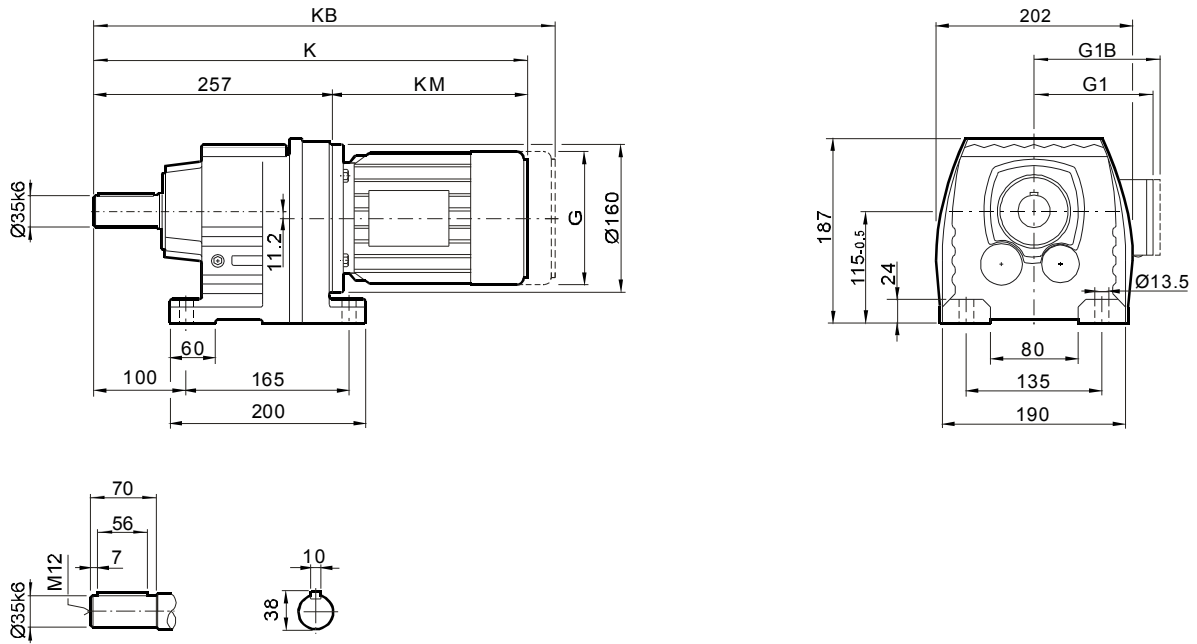

YR57F...

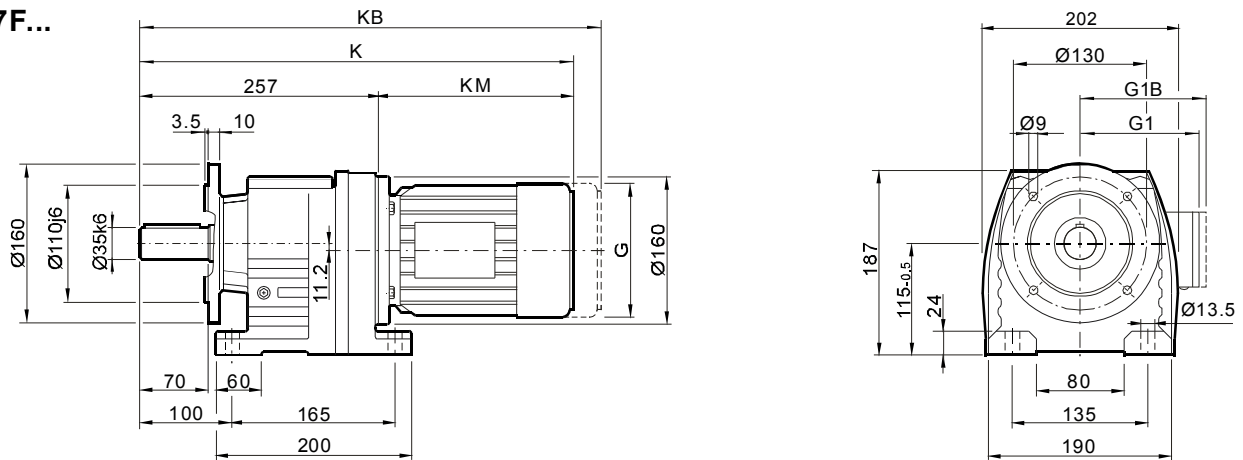

尺寸 Dimensions	电机规格 Motor frame									
	63	71	80	90	100M	100L	112M	132S	132M	
G	132	145	145	197	197	197	221	221	275	
G1	99	122	122	154	166	166	176	176	230	
G1B	99	127	127	161	166	166	182	182	230	
K	442	456	506	526	576	606	611	659	681	
KB	497	520	570	611	661	691	691	739	793	
KM	185	199	249	269	319	349	354	402	424	

尺寸说明

以上尺寸为直联普通电机和制动电机尺寸；
G1B,KB为制动电机尺寸,其余为普通电机尺寸；
防爆电机, 辊道电机, 船用电机等须加过渡法兰, 见135页。

ATTENTION

Dimensions of general and brake motor shown in upon table,
the others like explosion, roller, or marine motor coupled by
adaptor, the dimensions on page 135.



安装尺寸

Mounting Dimensions

YRF57...

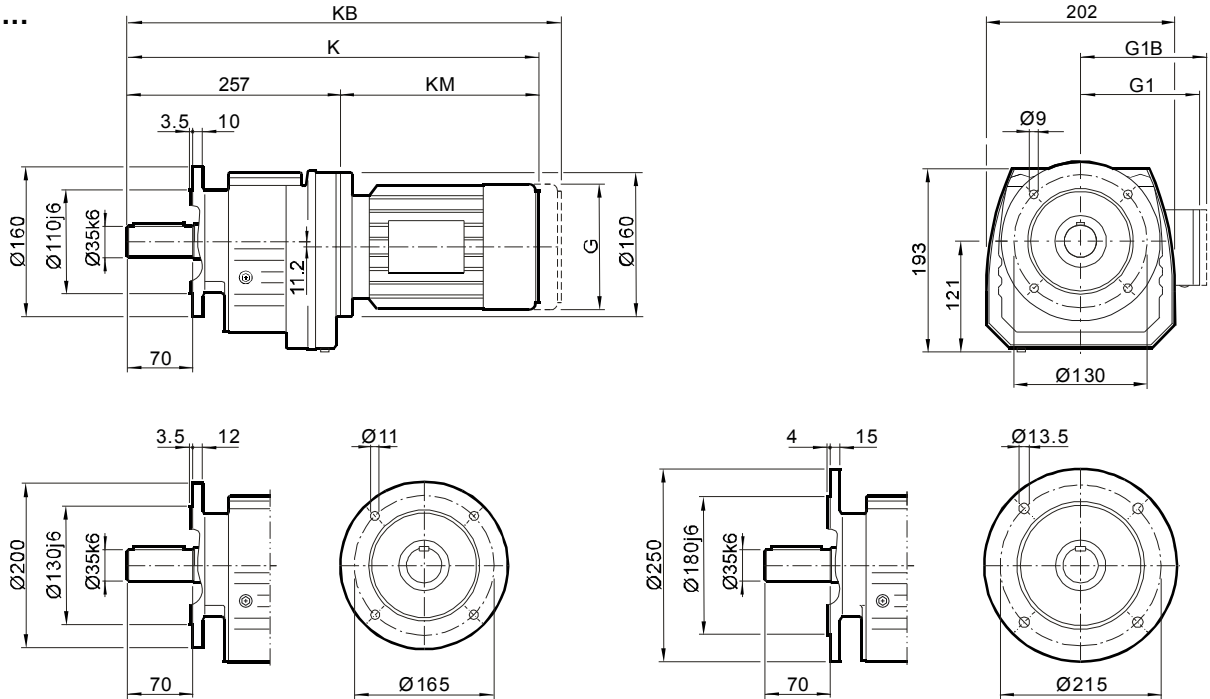

YRF57...

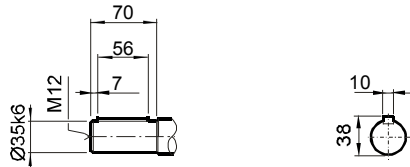

YRM57...

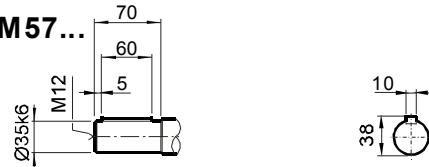

YRM57...

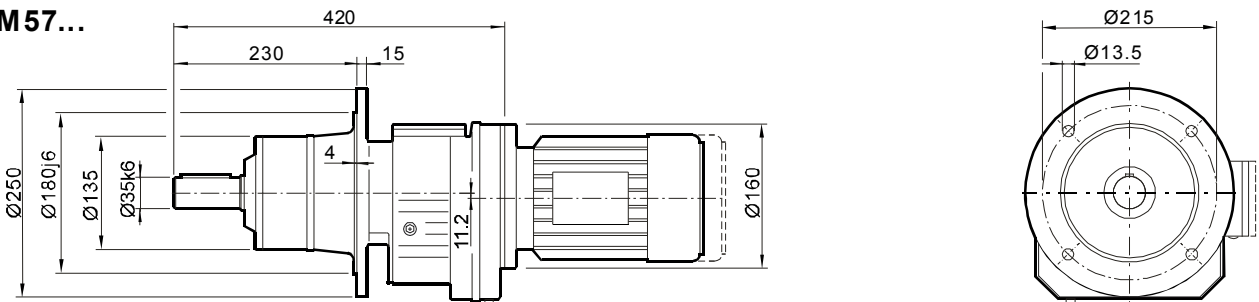

尺寸 Dimensions	电机规格 Motor frame									
	63	71	80	90	100M	100L	112M	132S	132M	
G	132	145	145	197	197	197	221	221	275	
G1	99	122	122	154	166	166	176	176	230	
G1B	99	127	127	161	166	166	182	182	230	
K	442	456	506	526	576	606	611	659	681	
KB	497	520	570	611	661	691	691	739	793	
KM	185	199	249	269	319	349	354	402	424	

尺寸说明

以上尺寸为直联普通电机和制动电机尺寸；
G1B,KB为制动电机尺寸,其余为普通电机尺寸；
防爆电机, 辊道电机, 船用电机等须加过渡法兰, 见135页。

ATTENTION

Dimensions of general and brake motor shown in upon table,
the others like explosion, roller, or marine motor coupled by
adaptor, the dimensions on page 135.



安装尺寸

Mounting Dimensions

YR67...

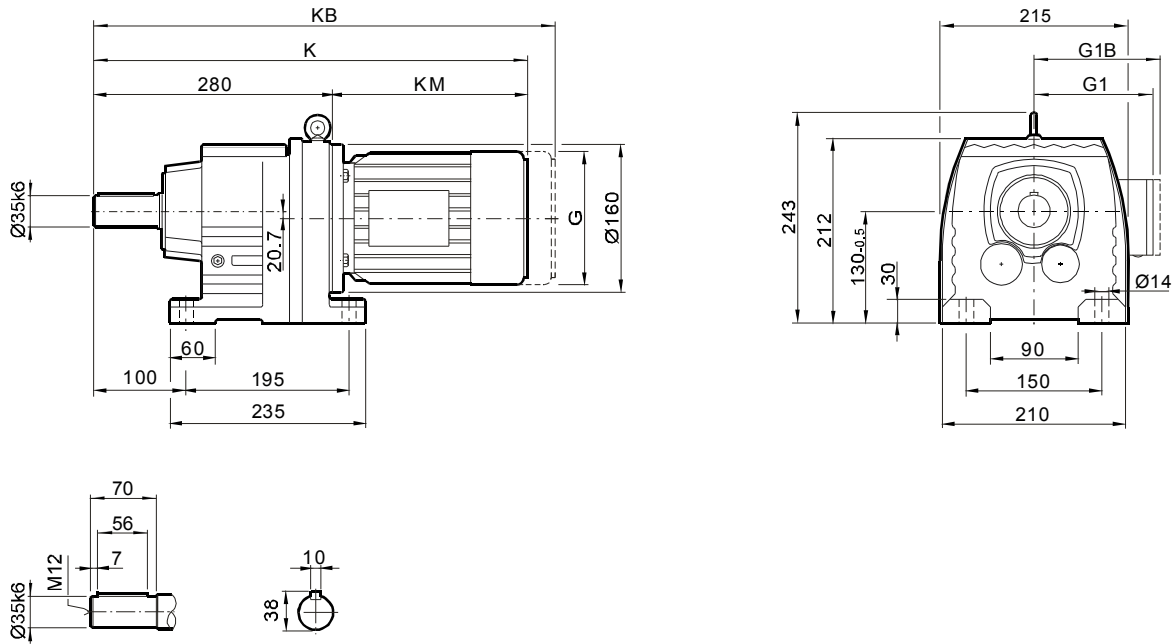

YR67F...

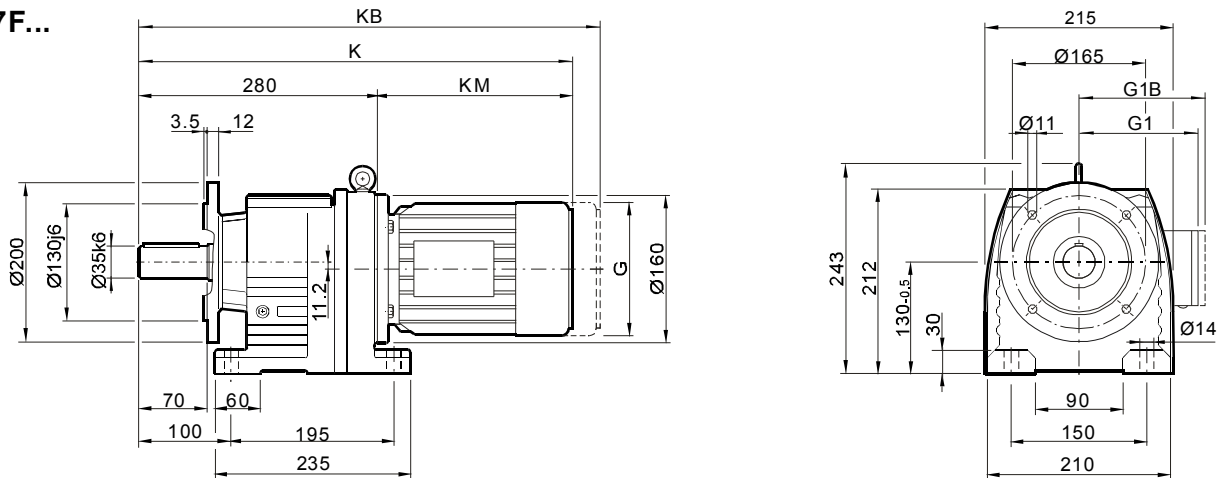

尺寸 Dimensions	电机规格 Motor frame									
	63	71	80	90	100M	100L	112M	132S	132M	
G	132	145	145	197	197	197	221	221	275	
G1	99	122	122	154	166	166	176	176	230	
G1B	99	127	127	161	166	166	182	182	230	
K	465	479	529	549	599	629	634	682	704	
KB	520	543	593	634	684	714	714	762	816	
KM	185	199	249	269	319	349	354	402	424	

尺寸说明

以上尺寸为直联普通电机和制动电机尺寸；
G1B,KB为制动电机尺寸,其余为普通电机尺寸；
防爆电机, 辊道电机, 船用电机等须加过渡法兰, 见135页。

ATTENTION

Dimensions of general and brake motor shown in upon table, the others like explosion, roller, or marine motor coupled by adaptor, the dimensions on page 135.



安装尺寸

Mounting Dimensions

YRF67...

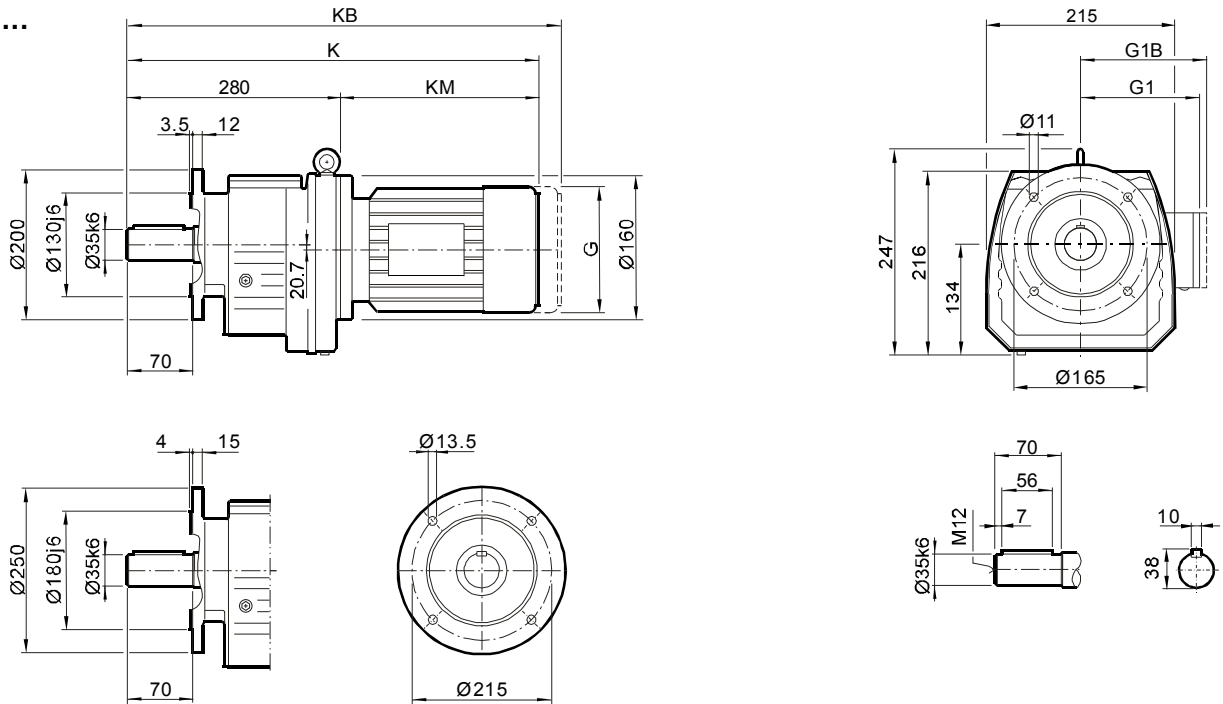

YRM67...

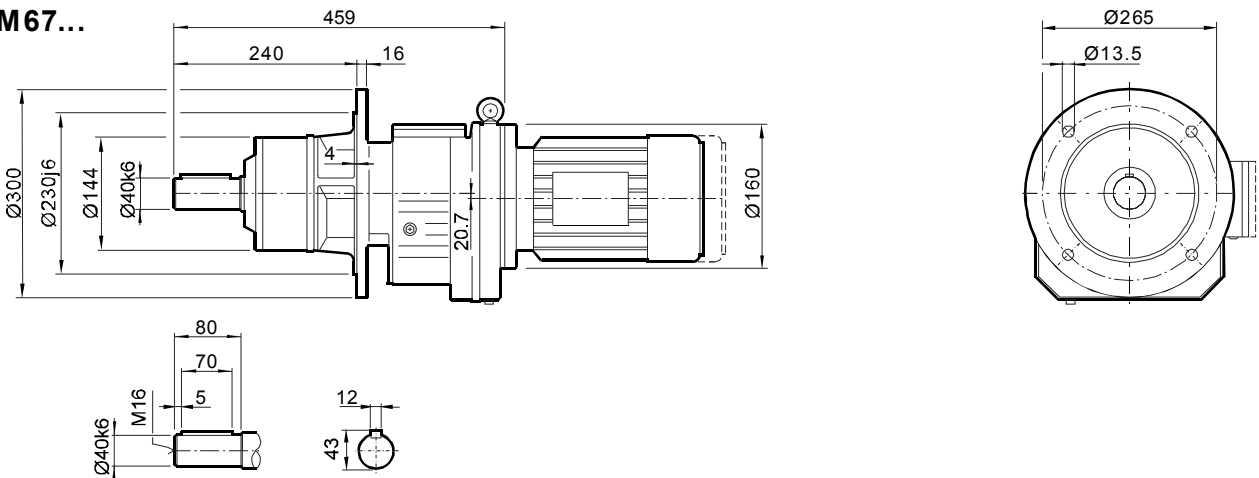

尺寸 Dimensions	电机规格 Motor frame									
	63	71	80	90	100M	100L	112M	132S	132M	
G	132	145	145	197	197	197	221	221	275	
G1	99	122	122	154	166	166	176	176	230	
G1B	99	127	127	161	166	166	182	182	230	
K	465	479	529	549	599	629	634	682	704	
KB	520	543	593	634	684	714	714	762	816	
KM	185	199	249	269	319	349	354	402	424	

尺寸说明

以上尺寸为直联普通电机和制动电机尺寸；
G1B,KB为制动电机尺寸,其余为普通电机尺寸；
防爆电机，辊道电机，船用电机等须加过渡法兰，见135页。

ATTENTION

Dimensions of general and brake motor shown in upon table,
the others like explosion, roller, or marine motor coupled by
adaptor, the dimensions on page 135.



安装尺寸

Mounting Dimensions

YR77...

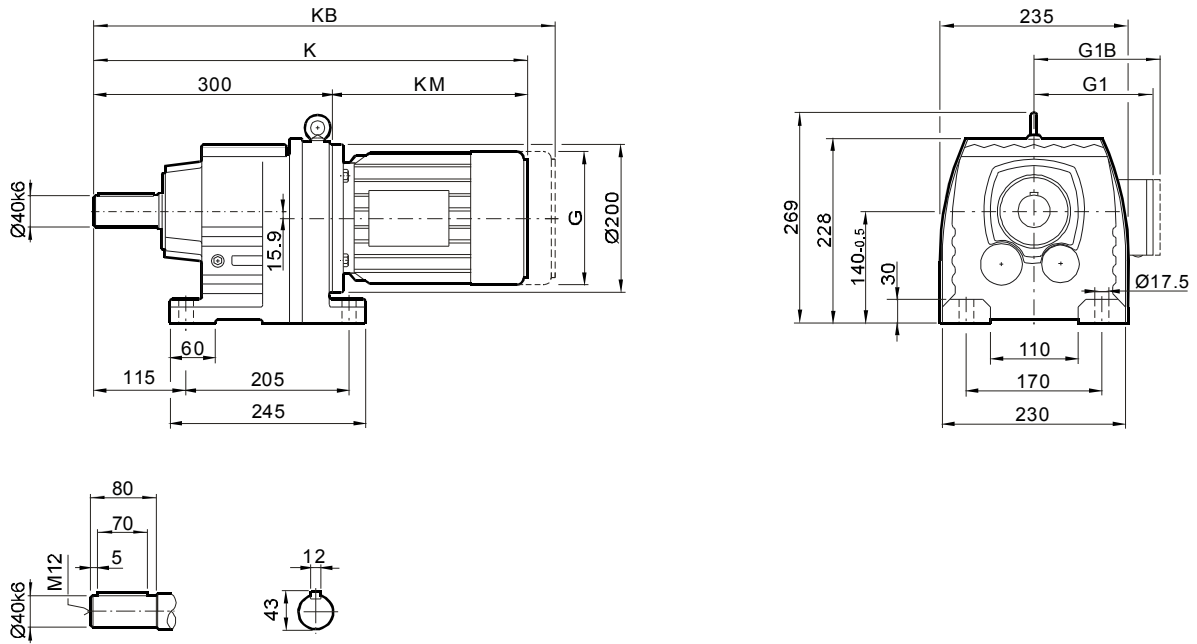

YR77F...

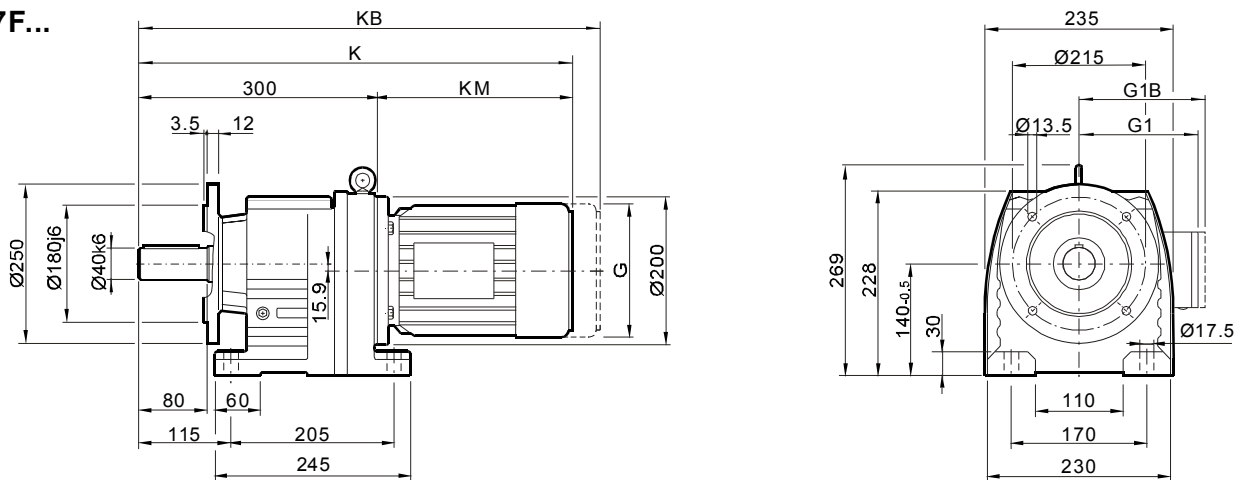

尺寸 Dimensions	电机规格 Motor frame									
	63	71	80	90	100M	100L	112M	132S	132M	160M
G	132	145	145	197	197	197	221	221	275	275
G1	99	122	122	154	166	166	176	176	230	230
G1B	99	127	127	161	166	166	182	182	230	230
K	479	493	543	561	611	641	645	690	712	772
KB	534	557	607	646	696	726	725	770	824	884
KM	179	193	243	261	311	341	345	390	412	472

尺寸说明

以上尺寸为直联普通电机和制动电机尺寸；
G1B,KB为制动电机尺寸,其余为普通电机尺寸；
防爆电机, 辊道电机, 船用电机等须加过渡法兰, 见135页。

ATTENTION

Dimensions of general and brake motor shown in upon table, the others like explosion, roller, or marine motor coupled by adaptor, the dimensions on page 135.



安装尺寸

Mounting Dimensions

YRF77...

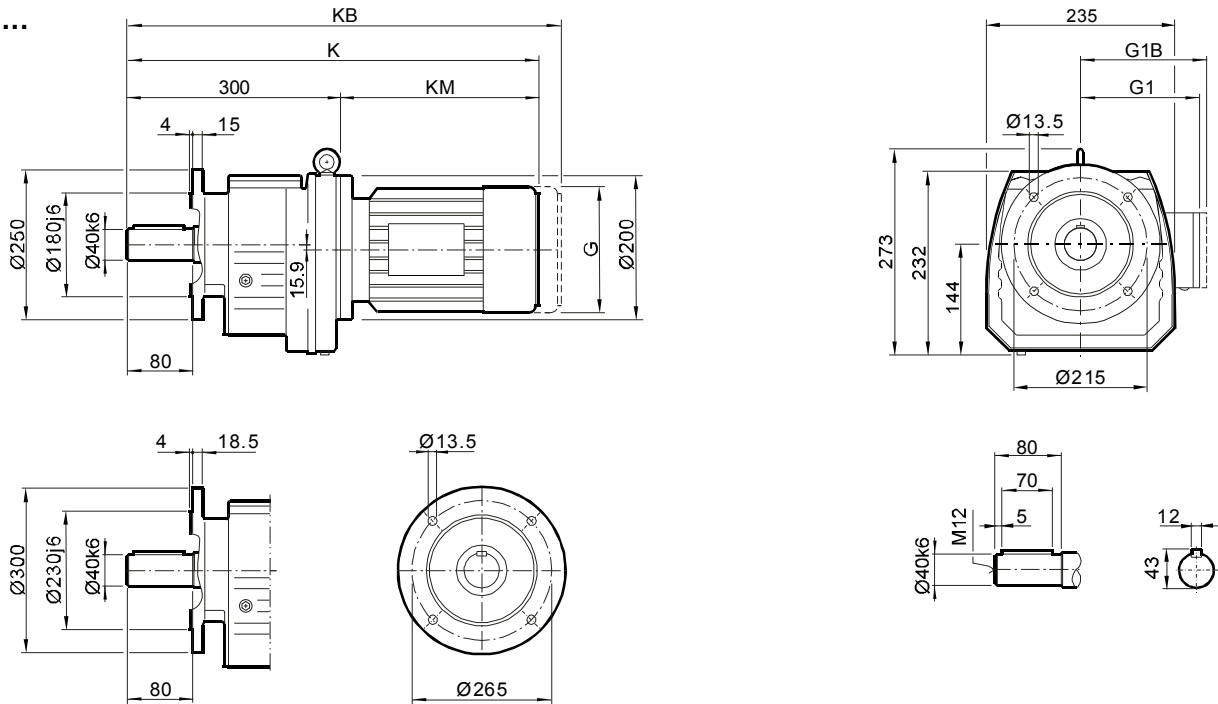

YRM77...

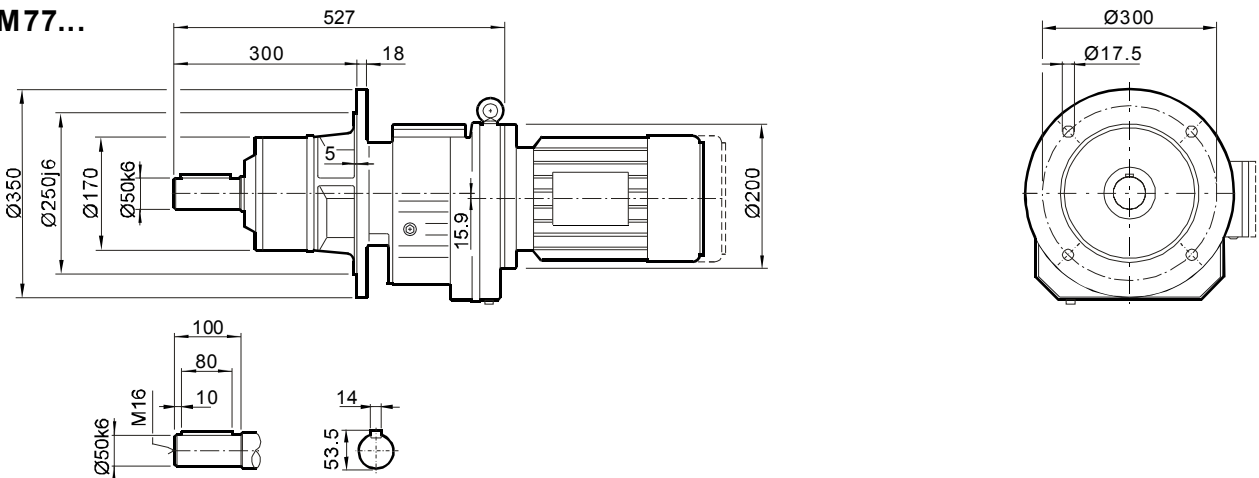

尺寸 Dimensions	电机规格 Motor frame									
	63	71	80	90	100M	100L	112M	132S	132M	160M
G	132	145	145	197	197	197	221	221	275	275
G1	99	122	122	154	166	166	176	176	230	230
G1B	99	127	127	161	166	166	182	182	230	230
K	479	493	543	561	611	641	645	690	712	772
KB	534	557	607	646	696	726	725	770	824	884
KM	179	193	243	261	311	341	345	390	412	472

尺寸说明

以上尺寸为直联普通电机和制动电机尺寸；
G1B,KB为制动电机尺寸,其余为普通电机尺寸；
防爆电机, 辊道电机, 船用电机等须加过渡法兰, 见135页。

ATTENTION

Dimensions of general and brake motor shown in upon table, the others like explosion, roller, or marine motor coupled by adaptor, the dimensions on page 135.



安装尺寸

Mounting Dimensions

YR87...

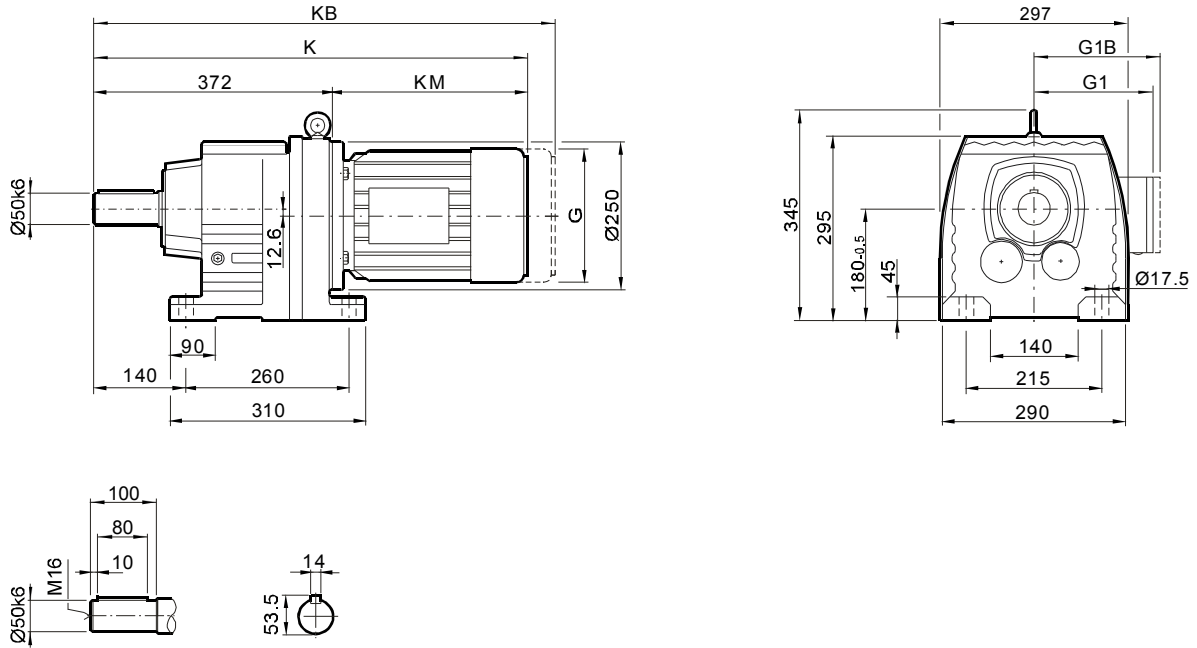

YR87F...

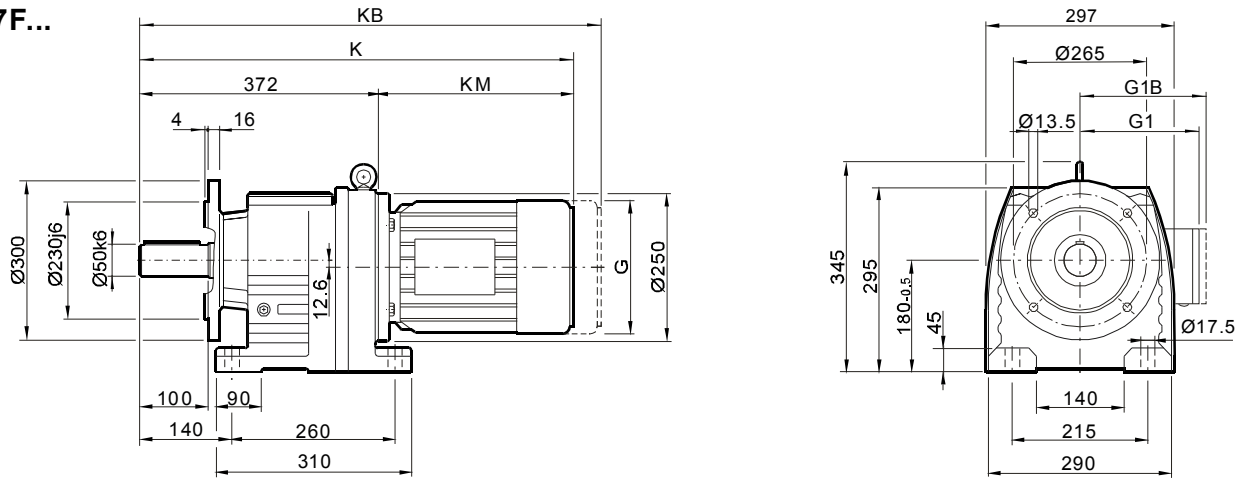

尺寸 Dimensions	电机规格 Motor frame									
	80	90	100M	100L	112M	132S	132M	160M	160L	180L
G	145	197	197	197	221	221	275	275	331	331
G1	122	154	166	166	176	176	230	230	259	253
G1B	127	161	166	166	182	182	230	230	259	253
K	610	629	679	709	712	757	779	839	886	958
KB	674	714	764	794	792	837	891	951	1042	1114
KM	238	257	307	337	340	385	407	467	514	586

尺寸说明

以上尺寸为直联普通电机和制动电机尺寸；
G1B,KB为制动电机尺寸,其余为普通电机尺寸；
防爆电机, 辊道电机, 船用电机等须加过渡法兰, 见135页。

ATTENTION

Dimensions of general and brake motor shown in upon table, the others like explosion, roller, or marine motor coupled by adaptor, the dimensions on page 135.



安装尺寸

Mounting Dimensions

YRF87...

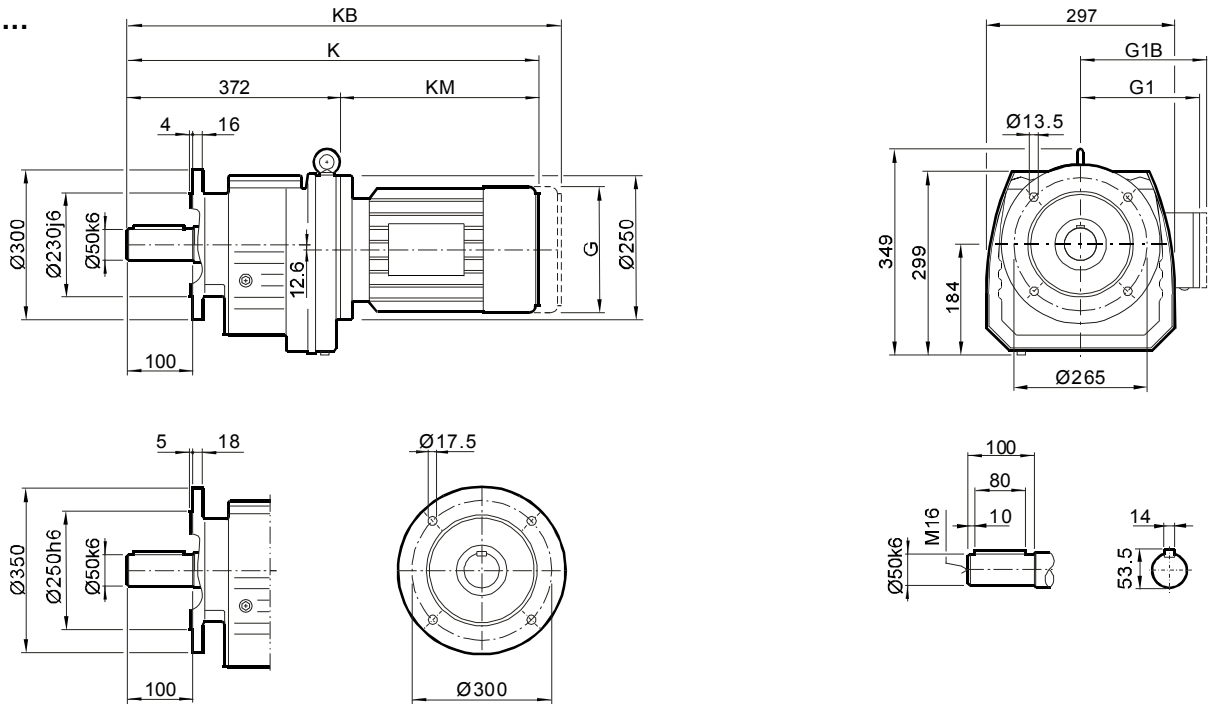

YRM87...

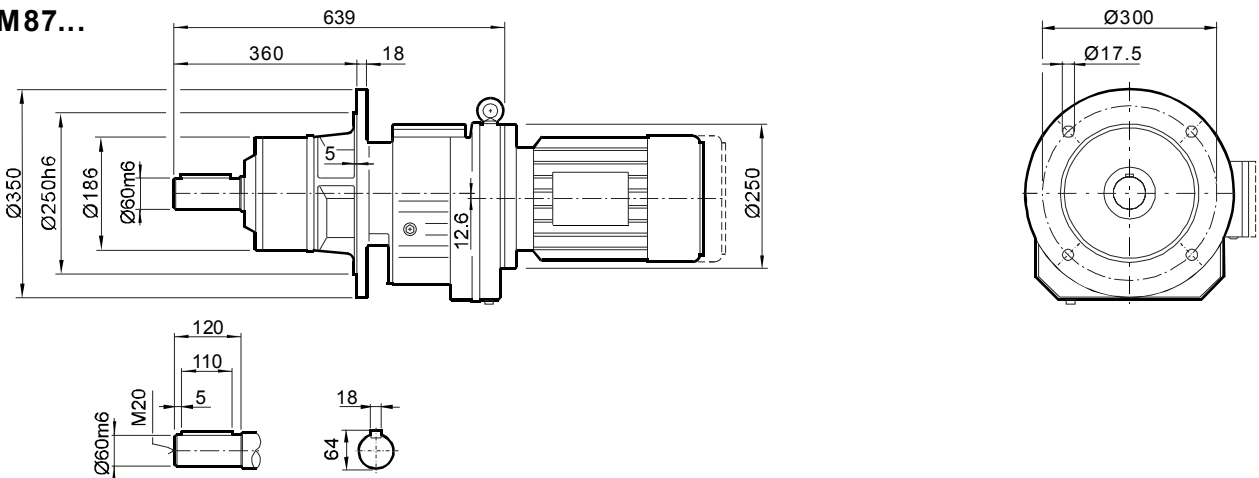

尺寸 Dimensions	电机规格 Motor frame									
	80	90	100M	100L	112M	132S	132M	160M	160L	180M
G	145	197	197	197	221	221	275	275	331	331
G1	122	154	166	166	176	176	230	230	259	253
G1B	127	161	166	166	182	182	230	230	259	253
K	610	629	679	709	712	757	779	839	886	958
KB	674	714	764	794	792	837	891	951	1042	1114
KM	238	257	307	337	340	385	407	467	514	586

尺寸说明

以上尺寸为直联普通电机和制动电机尺寸；
G1B,KB为制动电机尺寸,其余为普通电机尺寸；
防爆电机, 辊道电机, 船用电机等须加过渡法兰, 见135页。

ATTENTION

Dimensions of general and brake motor shown in upon table, the others like explosion, roller, or marine motor coupled by adaptor, the dimensions on page 135.



安装尺寸

Mounting Dimensions

YR97...

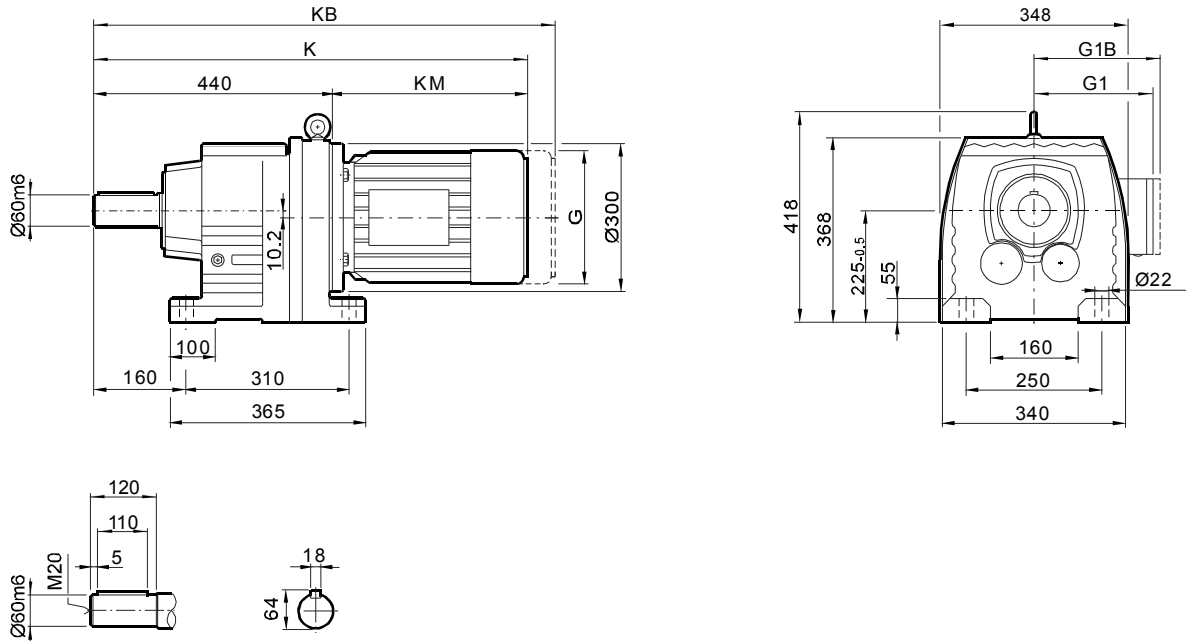

尺寸 Dimensions	电机规格 Motor frame										
	80	90	100M	100L	112M	132S	132M	160M	160L	180..	200..
G	145	197	197	197	221	221	275	275	331	331	394
G1	122	154	166	166	176	176	230	230	259	253	285
G1B	127	161	166	166	182	182	230	230	259	253	285
K	671	691	741	771	775	820	842	902	949	1021	1069
KB	735	776	826	856	855	900	954	1014	1105	1177	1225
KM	231	251	301	331	335	380	402	462	509	581	629

尺寸说明

以上尺寸为直联普通电机和制动电机尺寸；
G1B,KB为制动电机尺寸,其余为普通电机尺寸；
防爆电机, 辊道电机, 船用电机等须加过渡法兰, 见135页。

ATTENTION

Dimensions of general and brake motor shown in upon table,
the others like explosion, roller, or marine motor coupled by
adaptor, the dimensions on page 135.



安装尺寸

Mounting Dimensions

YRF97...

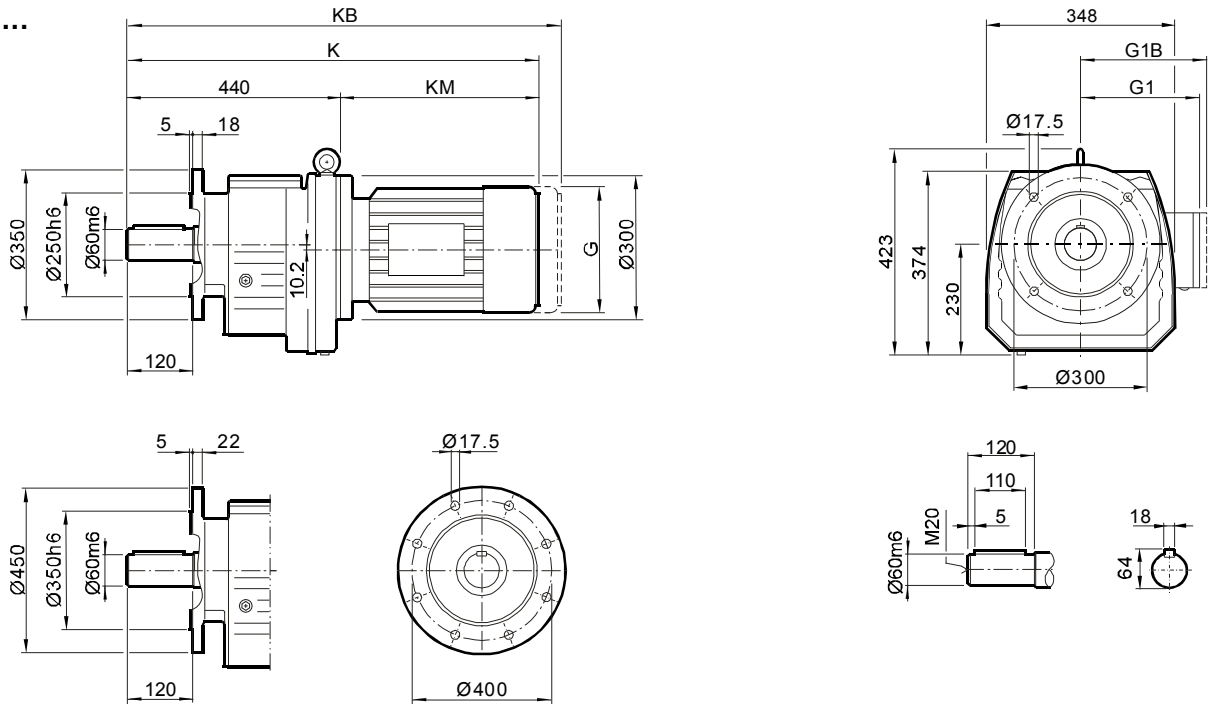

YRM97...

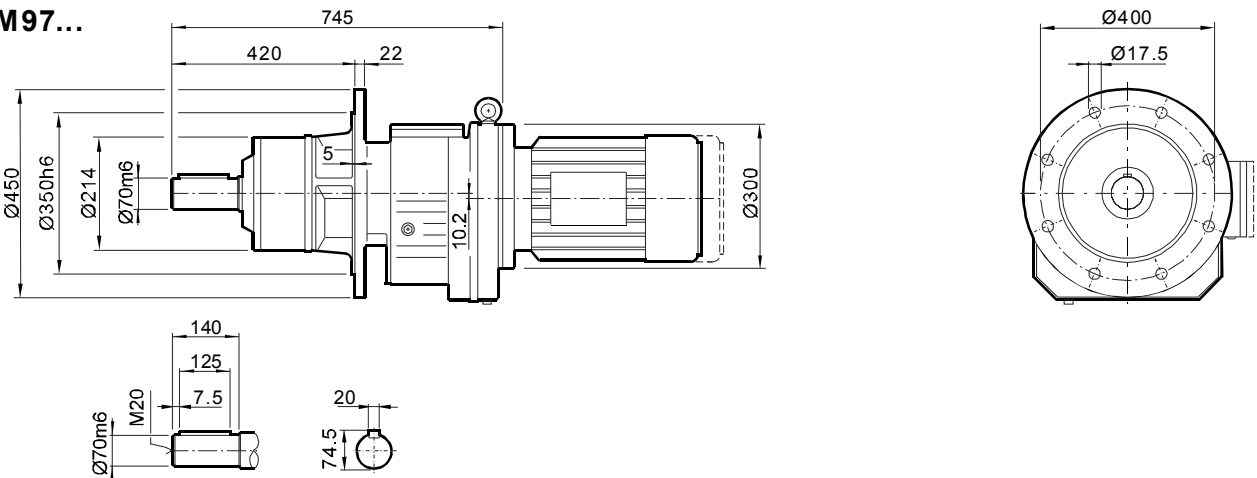

尺寸 Dimensions	电机规格 Motor frame										
	80	90	100M	100L	112M	132S	132M	160M	160L	180M	200M
G	145	197	197	197	221	221	275	275	331	331	394
G1	122	154	166	166	176	176	230	230	259	253	285
G1B	127	161	166	166	182	182	230	230	259	253	285
K	671	691	741	771	775	820	842	902	949	1021	1069
KB	735	776	826	856	855	900	954	1014	1105	1117	1225
KM	231	251	301	331	335	380	402	462	509	581	629

尺寸说明

以上尺寸为直联普通电机和制动电机尺寸；
G1B,KB为制动电机尺寸,其余为普通电机尺寸；
防爆电机, 辊道电机, 船用电机等须加过渡法兰, 见135页。

ATTENTION

Dimensions of general and brake motor shown in upon table, the others like explosion, roller, or marine motor coupled by adaptor, the dimensions on page 135.



安装尺寸

Mounting Dimensions

YR107...

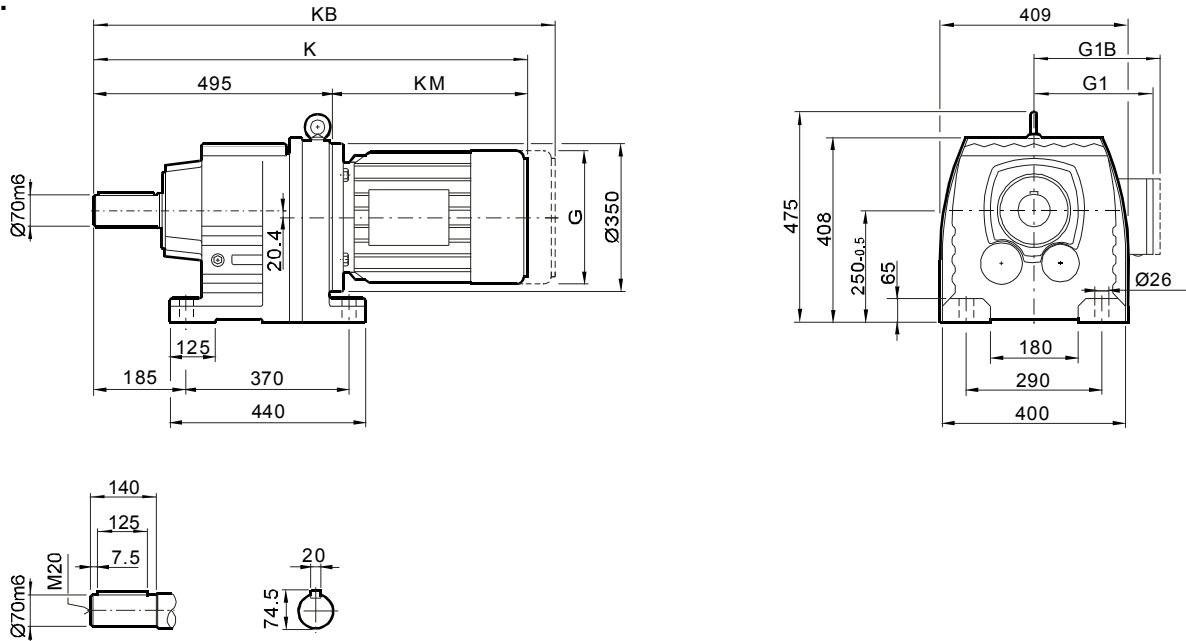

尺寸 Dimensions	电机规格 Motor frame										
	100M	100L	112M	132S	132M	160M	160L	180..	200..	225..	
G	197	197	221	221	275	275	331	331	394	394	
G1	166	166	176	176	230	230	259	253	285	289	
G1B	166	166	182	182	230	230	259	253	285	289	
K	790	820	824	869	891	951	998	1070	1069	1200	
KB	875	905	904	949	1003	1063	1154	1226	1225	1356	
KM	295	325	329	374	396	456	503	575	629	705	

尺寸说明

以上尺寸为直联普通电机和制动电机尺寸；
G1B,KB为制动电机尺寸,其余为普通电机尺寸；
防爆电机, 辊道电机, 船用电机等须加过渡法兰, 见136页。

ATTENTION

Dimensions of general and brake motor shown in upon table,
the others like explosion, roller, or marine motor coupled by
adaptor, the dimensions on page 136.



安装尺寸

Mounting Dimensions

YRF107...

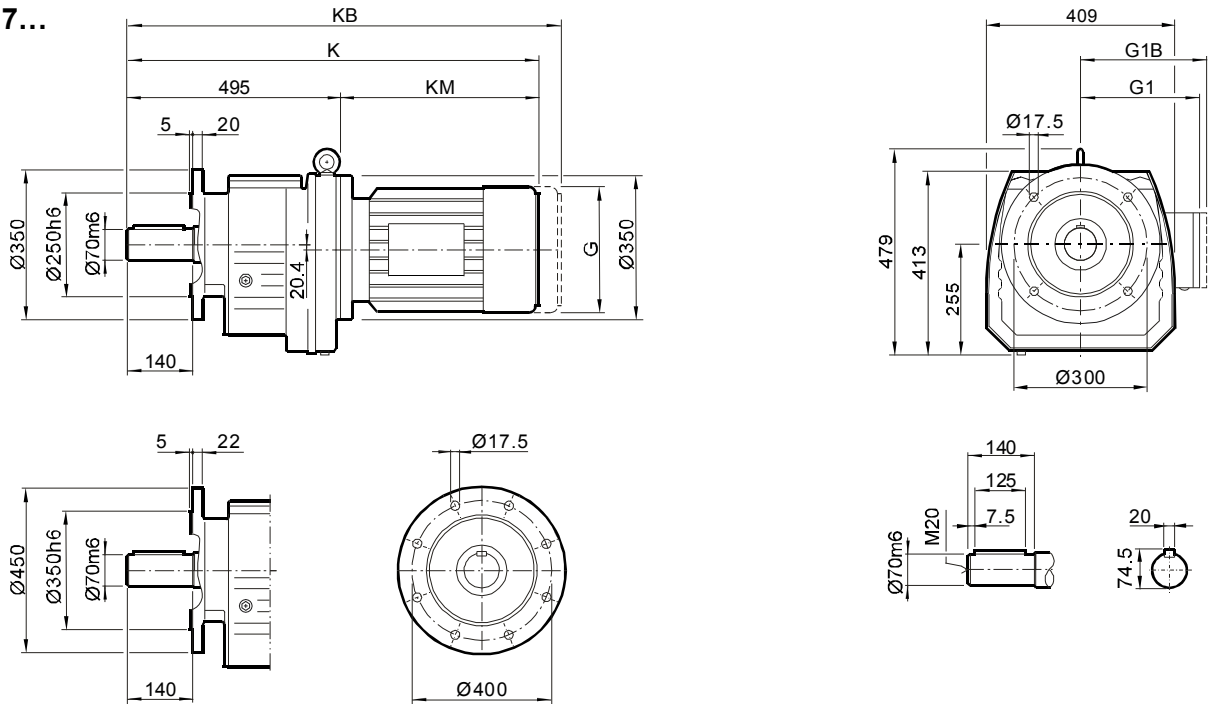

YRM107...

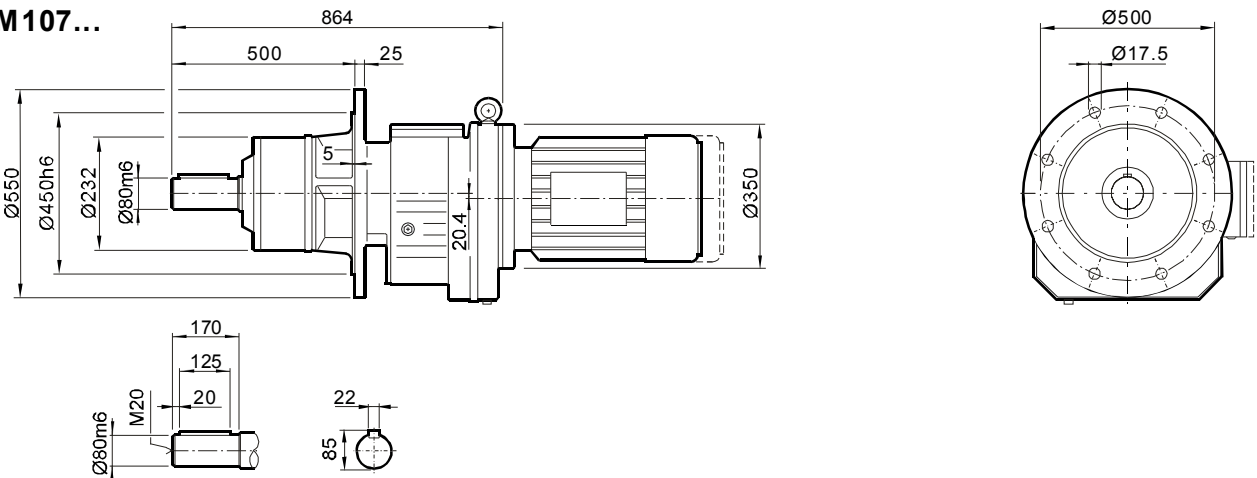

尺寸 Dimensions	电机规格 Motor frame									
	100M	100L	112M	132S	132M	160M	160L	180M	200..	225..
G	197	197	221	221	275	275	331	331	394	394
G1	166	166	176	176	230	230	259	253	285	289
G1B	166	166	182	182	230	230	259	253	285	289
K	790	820	824	869	891	951	998	1070	1118	1200
KB	875	905	904	949	1003	1063	1154	1226	1274	1356
KM	295	325	329	374	396	456	503	575	623	705

尺寸说明

以上尺寸为直联普通电机和制动电机尺寸；
G1B,KB为制动电机尺寸,其余为普通电机尺寸；
防爆电机, 辊道电机, 船用电机等须加过渡法兰, 见136页。

ATTENTION

Dimensions of general and brake motor shown in upon table, the others like explosion, roller, or marine motor coupled by adaptor, the dimensions on page 136.



安装尺寸

Mounting Dimensions

YR137...

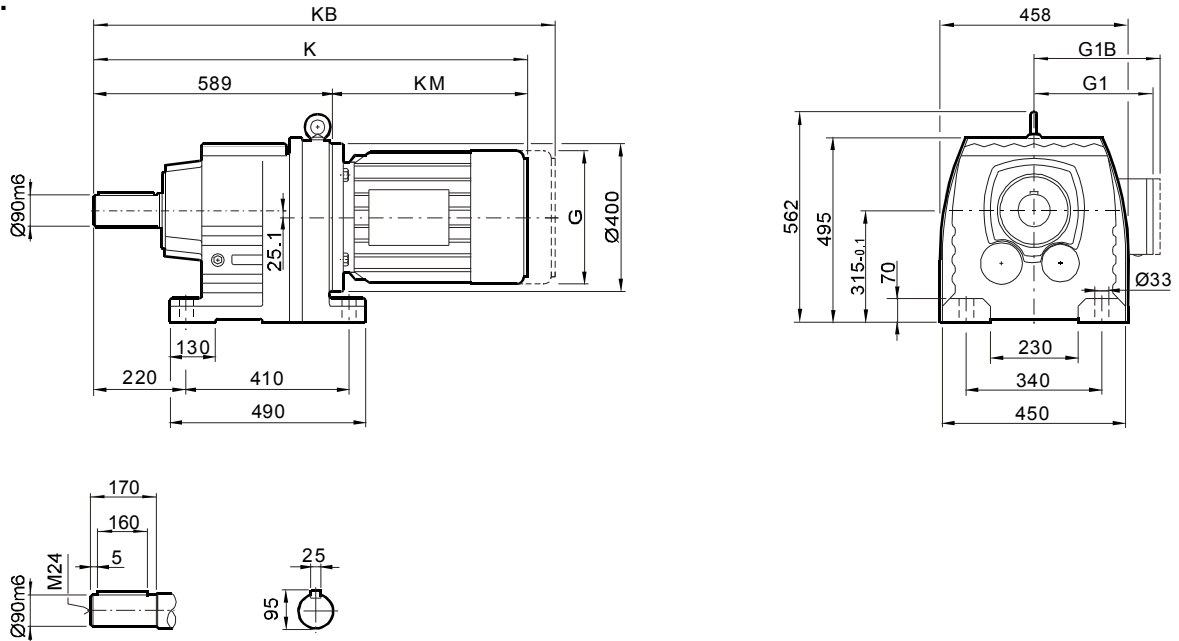

尺寸 Dimensions	电机规格 Motor frame								
	132S	132M	160M	160L	180..	200..	225..	250M	
G	221	275	275	331	331	394	394	480	
G1	176	230	230	259	253	285	289	350	
G1B	182	230	230	259	253	285	289	350	
K	956	978	1038	1085	1157	1205	1287	1350	
KB	1036	1090	1150	1241	1313	1361	1443	1571	
KM	367	389	449	496	568	616	698	761	

尺寸说明

以上尺寸为直联普通电机和制动电机尺寸；
G1B,KB为制动电机尺寸,其余为普通电机尺寸；
防爆电机, 辊道电机, 船用电机等须加过渡法兰, 见136页。

ATTENTION

Dimensions of general and brake motor shown in upon table,
the others like explosion, roller, or marine motor coupled by
adaptor, the dimensions on page 136.



安装尺寸

Mounting Dimensions

YRF137...

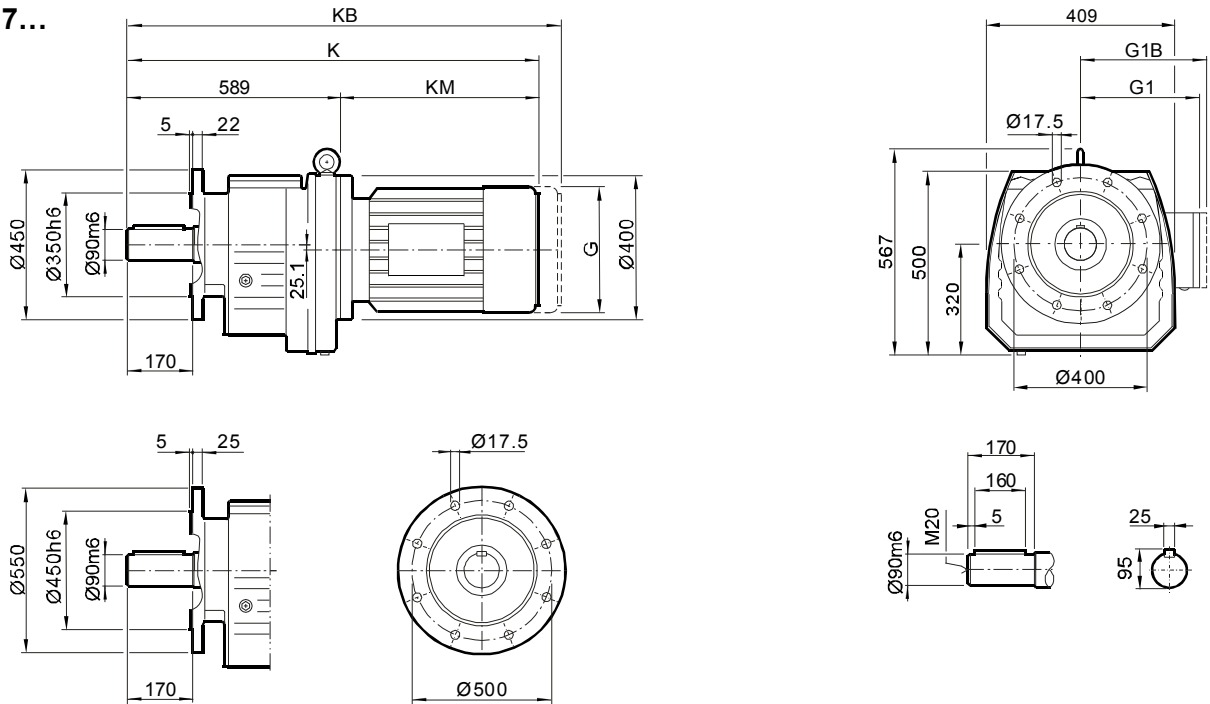

YRM137...

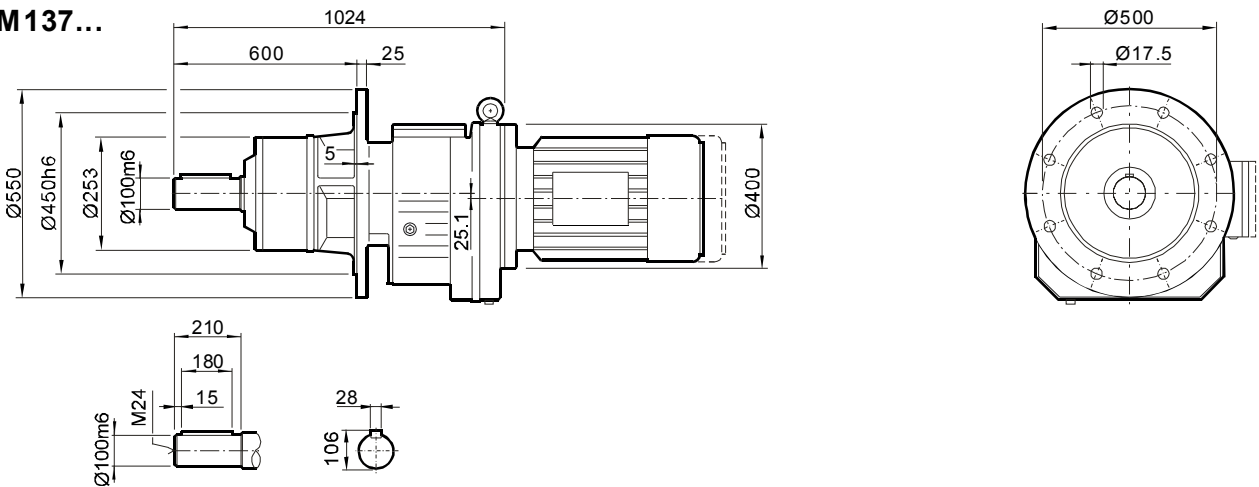

尺寸 Dimensions	电机规格 Motor frame							
	132S	132M	160M	160L	180..	200..	225..	250M
G	221	275	275	331	331	394	394	480
G1	176	230	230	259	253	285	289	350
G1B	182	230	230	259	253	285	289	350
K	956	978	1038	1085	1157	1205	1287	1350
KB	1036	1090	1150	1241	1313	1361	1443	1571
KM	367	389	449	496	568	616	698	761

尺寸说明

以上尺寸为直联普通电机和制动电机尺寸；
G1B,KB为制动电机尺寸,其余为普通电机尺寸；
防爆电机, 辊道电机, 船用电机等须加过渡法兰, 见136页。

ATTENTION

Dimensions of general and brake motor shown in upon table, the others like explosion, roller, or marine motor coupled by adaptor, the dimensions on page 136.



安装尺寸

Mounting Dimensions

YR147...

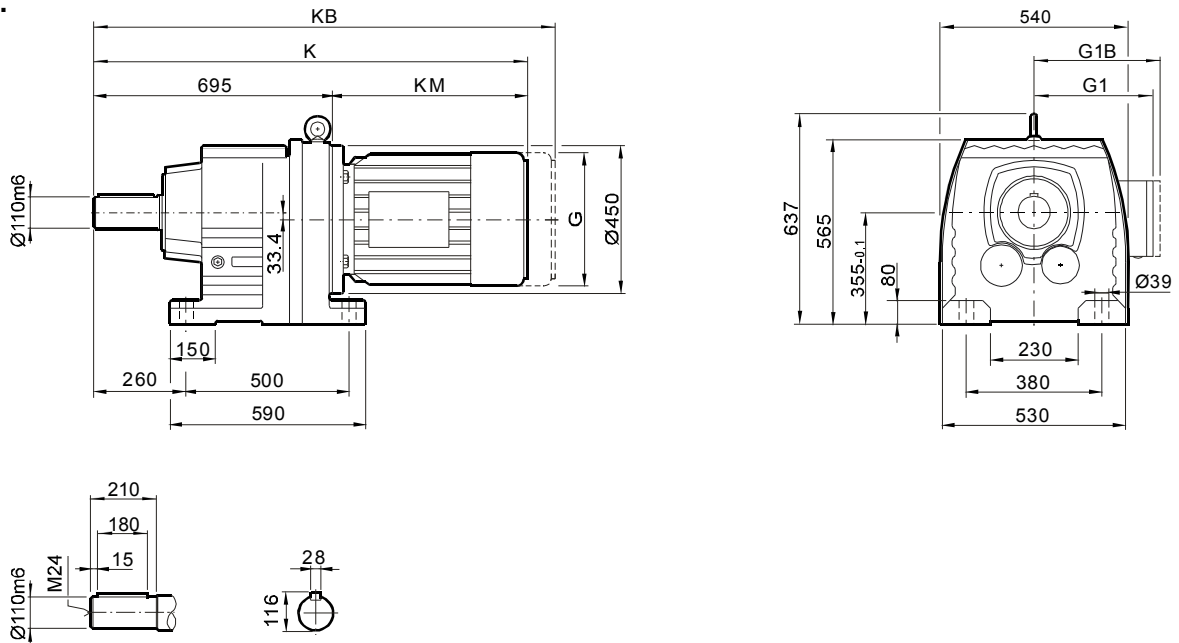

尺寸 Dimensions	电机规格 Motor frame								
	160M	160L	180M	200..	225..	250M	280S	280M	
G	275	331	331	394	394	480	537	537	
G1	230	259	253	285	289	350	382	382	
G1B	230	259	253	285	289	350	382	382	
K	1136	1183	1255	1303	1385	1472	1550	1601	
KB	1248	1339	1411	1459	1541	1693	1761	1821	
KM	441	488	560	608	690	777	855	906	

尺寸说明

以上尺寸为直联普通电机和制动电机尺寸；
G1B,KB为制动电机尺寸,其余为普通电机尺寸；
防爆电机, 辊道电机, 船用电机等须加过渡法兰, 见136页。

ATTENTION

Dimensions of general and brake motor shown in upon table,
the others like explosion, roller, or marine motor coupled by
adaptor, the dimensions on page 136.



安装尺寸

Mounting Dimensions

YRF147...

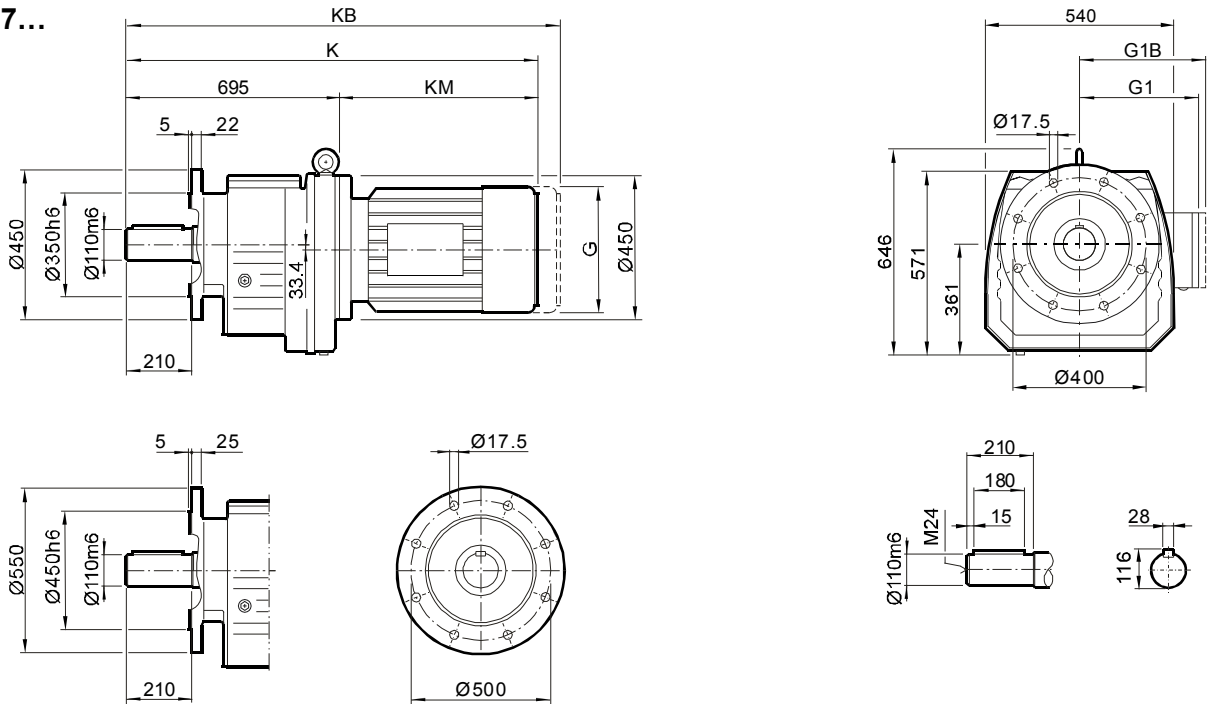

YRM147...

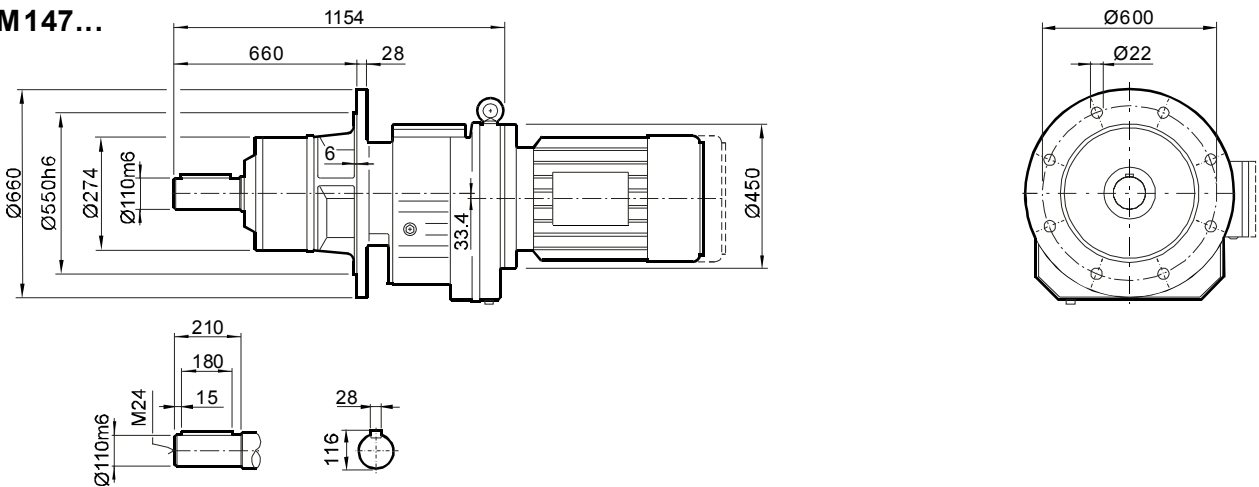

尺寸 Dimensions	电机规格 Motor frame									
	160M	160L	180M	200..	225..	250M	280S	280M		
G	275	331	331	394	394	480	537	537		
G1	230	259	253	285	289	350	382	382		
G1B	230	259	253	285	289	350	382	382		
K	1136	1183	1255	1303	1385	1472	1550	1601		
KB	1248	1339	1411	1459	1541	1693	1761	1821		
KM	441	488	560	608	690	777	855	906		

尺寸说明

以上尺寸为直联普通电机和制动电机尺寸；
G1B,KB为制动电机尺寸,其余为普通电机尺寸；
防爆电机, 辊道电机, 船用电机等须加过渡法兰, 见136页。

ATTENTION

Dimensions of general and brake motor shown in upon table, the others like explosion, roller, or marine motor coupled by adaptor, the dimensions on page 136.



安装尺寸

Mounting Dimensions

YR167...

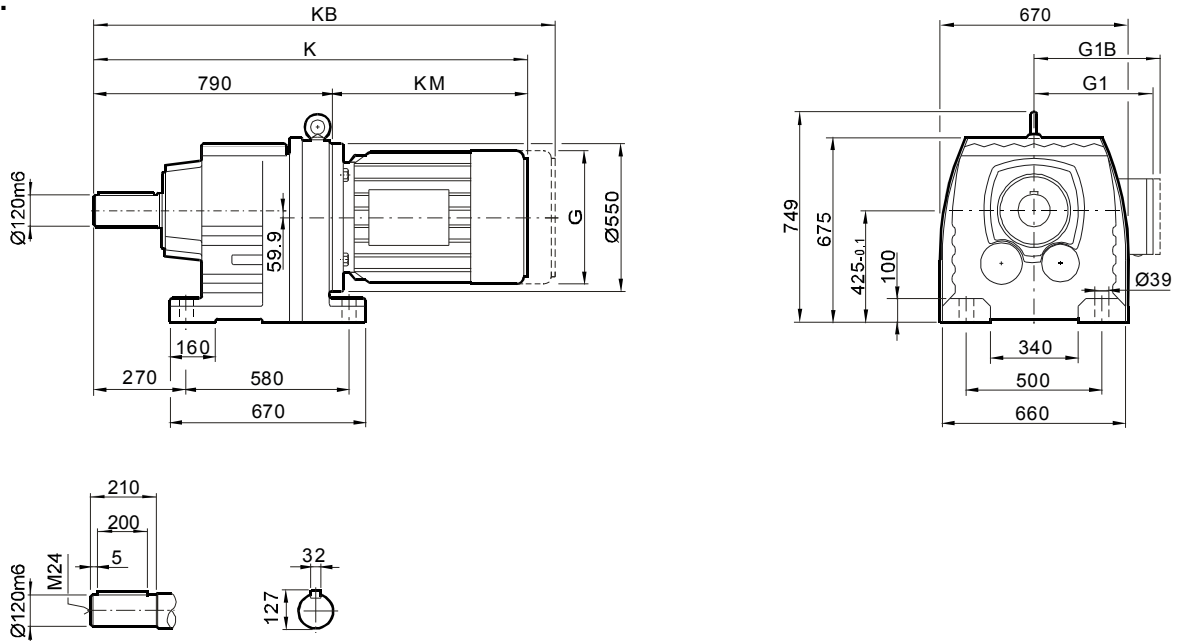

尺寸 Dimensions	电机规格 Motor frame									
	160M	160L	180..	200..	225..	250M	280S	315S	315M	
G	275	331	331	394	394	480	537	612	612	
G1	230	259	253	285	289	350	382	430	430	
G1B	230	259	253	285	289	350	382	430	430	
K	1223	1270	1342	1390	1472	1589	1663	1765	1816	
KB	1335	1426	1498	1546	1628	1810	1874	1993	2044	
KM	433	480	552	600	682	799	873	975	1026	

尺寸说明

以上尺寸为直联普通电机和制动电机尺寸；
G1B,KB为制动电机尺寸,其余为普通电机尺寸；
防爆电机，辊道电机，船用电机等须加过渡法兰，见136页。

ATTENTION

Dimensions of general and brake motor shown in upon table,
the others like explosion, roller, or marine motor coupled by
adaptor, the dimensions on page 136.



安装尺寸

Mounting Dimensions

YRF167...

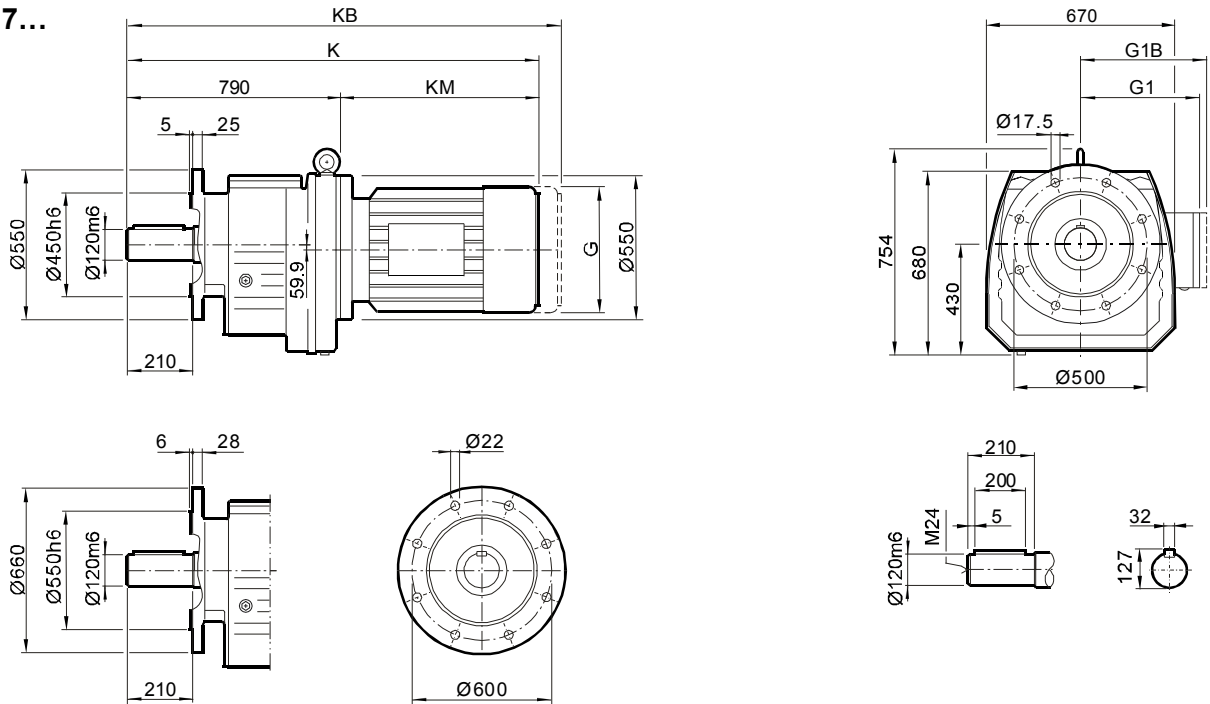

YRM167...

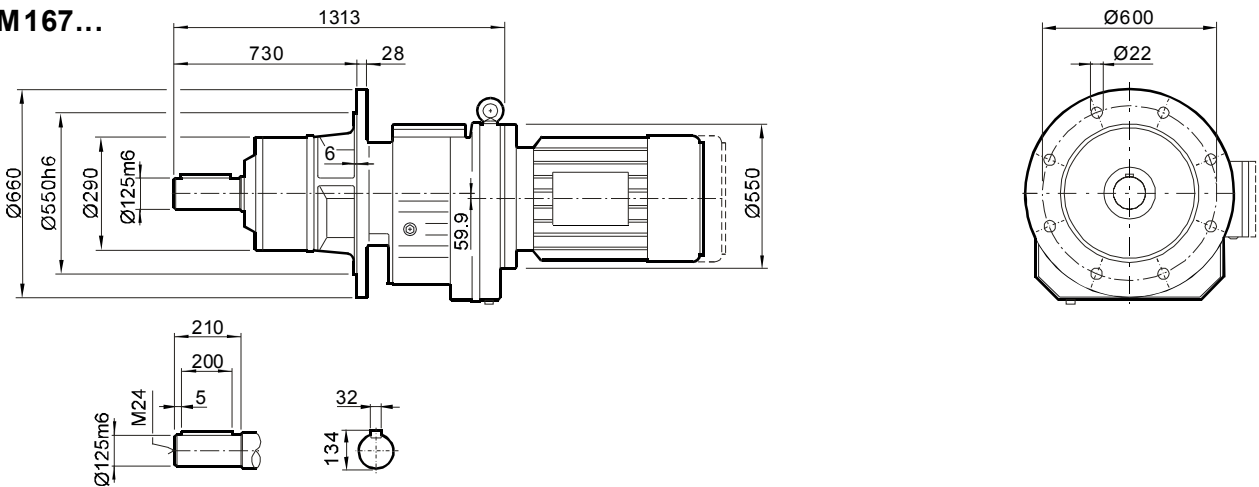

尺寸 Dimensions	电机规格 Motor frame									
	160M	160L	180M	200..	225..	250M	280S	280M	315S	315M
G	275	331	331	394	394	480	537	537	612	612
G1	230	259	253	285	289	350	382	382	430	430
G1B	230	259	253	285	289	350	382	382	430	430
K	1223	1270	1342	1390	1472	1589	1663	1714	1765	1816
KB	1335	1426	1498	1546	1628	1810	1874	1925	1993	2044
KM	433	480	552	600	682	799	873	924	975	1026

尺寸说明

以上尺寸为直联普通电机和制动电机尺寸；
G1B,KB为制动电机尺寸,其余为普通电机尺寸；
防爆电机, 辊道电机, 船用电机等须加过渡法兰, 见136页。

ATTENTION

Dimensions of general and brake motor shown in upon table, the others like explosion, roller, or marine motor coupled by adaptor, the dimensions on page 136.



安装尺寸

Mounting Dimensions

YRX57...

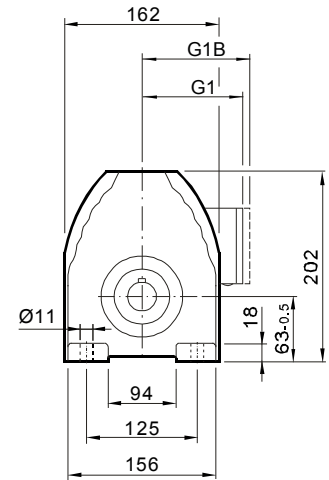
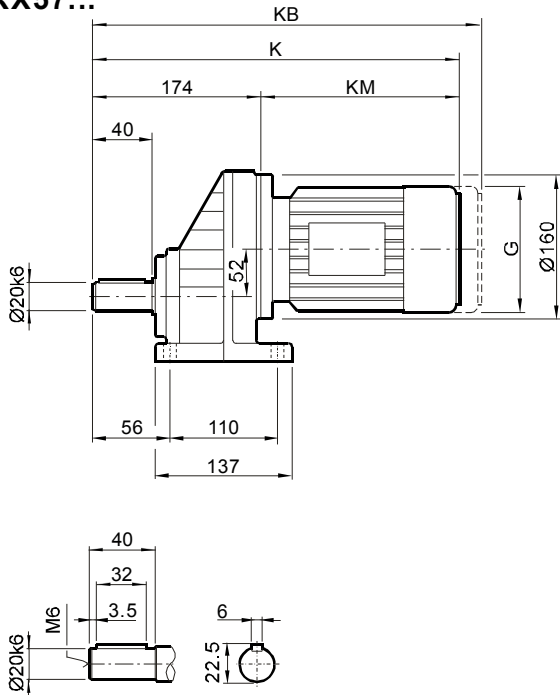

尺寸 Dimensions	电机规格 Motor frame								
	63	71	80	90	100M	100L	112M	132S	
G	132	145	145	197	197	197	221	221	
G1	99	122	122	154	166	166	176	176	
G1B	99	127	127	161	166	166	182	182	
K	386	400	450	470	520	550	555	603	
KB	441	464	514	555	605	635	635	683	
KM	185	199	249	269	319	349	354	402	

尺寸说明

以上尺寸为直联普通电机和制动电机尺寸；
G1B,KB为制动电机尺寸,其余为普通电机尺寸；
防爆电机, 辊道电机, 船用电机等须加过渡法兰, 见135页。

ATTENTION

Dimensions of general and brake motor shown in upon table, the others like explosion, roller, or marine motor coupled by adaptor, the dimensions on page 135.



安装尺寸

Mounting Dimensions

YRXF57...

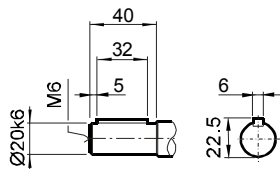
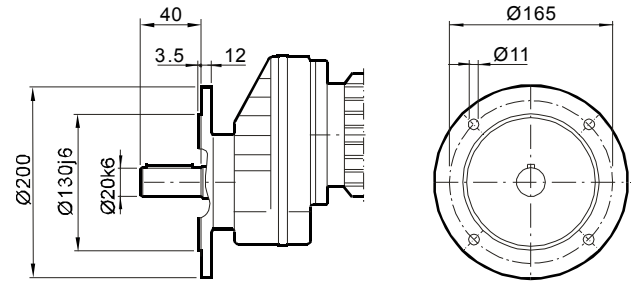
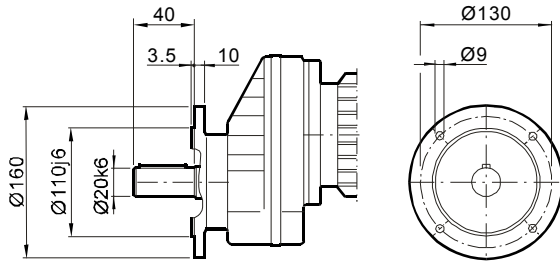
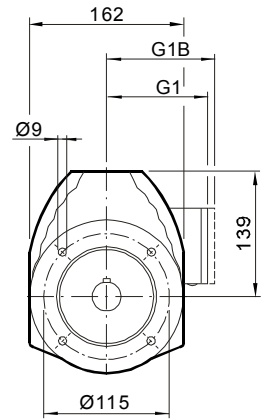
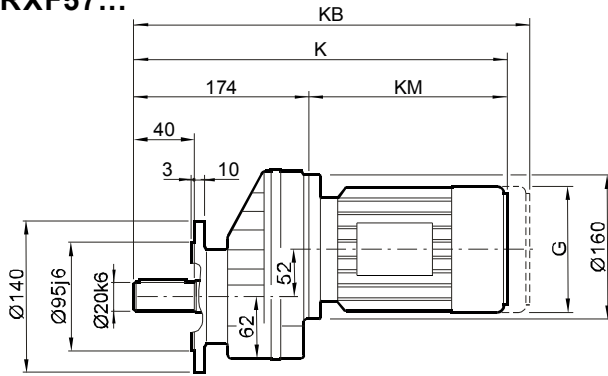

尺寸 Dimensions	电机规格 Motor frame								
	63	71	80	90	100M	100L	112M	132S	
G	132	145	145	197	197	197	221	221	
G1	99	122	122	154	166	166	176	176	
G1B	99	127	127	161	166	166	182	182	
K	386	400	450	470	520	550	555	603	
KB	441	464	514	555	605	635	635	683	
KM	185	199	249	269	319	349	354	402	

尺寸说明

以上尺寸为直联普通电机和制动电机尺寸；
G1B,KB为制动电机尺寸,其余为普通电机尺寸；
防爆电机, 辊道电机, 船用电机等须加过渡法兰, 见135页。

ATTENTION

Dimensions of general and brake motor shown in upon table, the others like explosion, roller, or marine motor coupled by adaptor, the dimensions on page 135.



安装尺寸

Mounting Dimensions

YRX67...

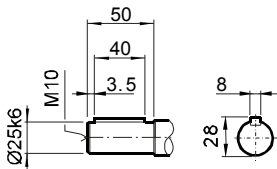
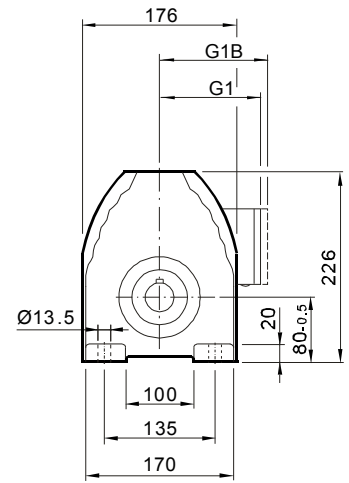
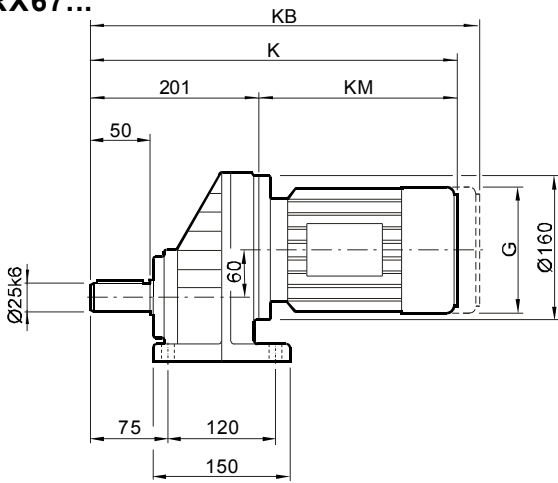

尺寸 Dimensions	电机规格 Motor frame									
	63	71	80	90	100M	100L	112M	132S	132M	
G	132	145	145	197	197	197	221	221	275	
G1	99	122	122	154	166	166	176	176	230	
G1B	99	127	127	161	166	166	182	182	230	
K	386	400	450	470	520	550	555	603	625	
KB	441	464	514	555	605	635	635	683	737	
KM	185	199	249	269	319	349	354	402	424	

尺寸说明

以上尺寸为直联普通电机和制动电机尺寸；
G1B,KB为制动电机尺寸,其余为普通电机尺寸；
防爆电机，辊道电机，船用电机等须加过渡法兰，见135页。

ATTENTION

Dimensions of general and brake motor shown in upon table, the others like explosion, roller, or marine motor coupled by adaptor, the dimensions on page 135.



安装尺寸

Mounting Dimensions

YRXF67...

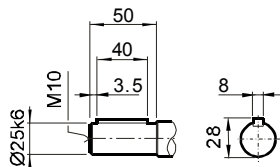
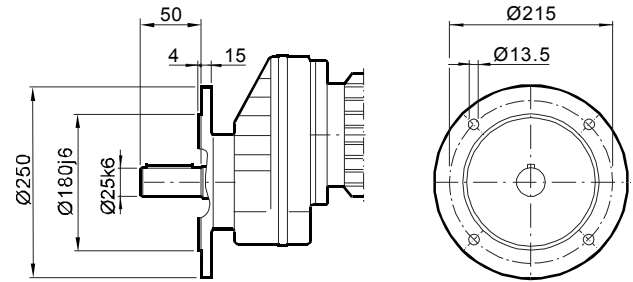
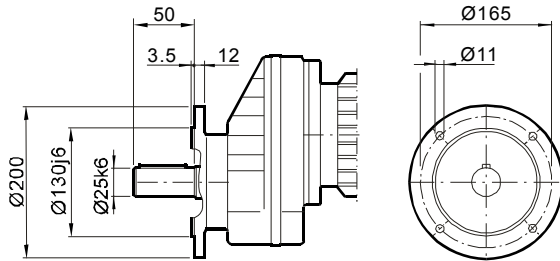
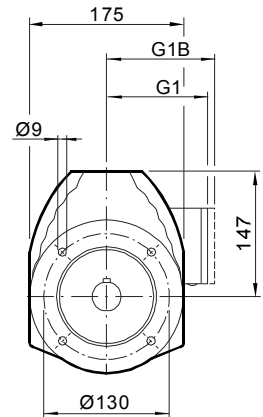
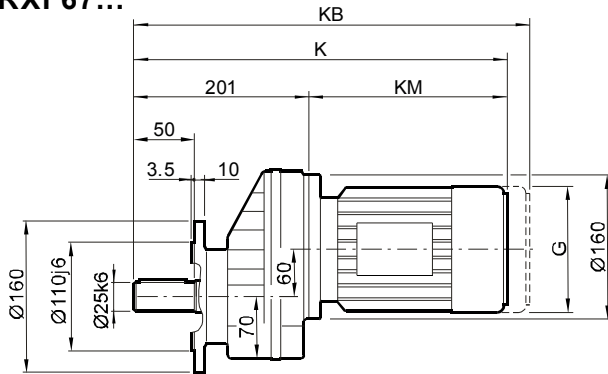

尺寸 Dimensions	电机规格 Motor frame									
	63	71	80	90	100M	100L	112M	132S	132M	
G	132	145	145	197	197	197	221	221	275	
G1	99	122	122	154	166	166	176	176	230	
G1B	99	127	127	161	166	166	182	182	230	
K	386	400	450	470	520	550	555	603	625	
KB	441	464	514	555	605	635	635	683	737	
KM	185	199	249	269	319	349	354	402	424	

尺寸说明

以上尺寸为直联普通电机和制动电机尺寸；
G1B,KB为制动电机尺寸,其余为普通电机尺寸；
防爆电机, 辊道电机, 船用电机等须加过渡法兰, 见135页。

ATTENTION

Dimensions of general and brake motor shown in upon table, the others like explosion, roller, or marine motor coupled by adaptor, the dimensions on page 135.



安装尺寸

Mounting Dimensions

YRX77...

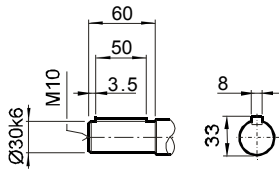
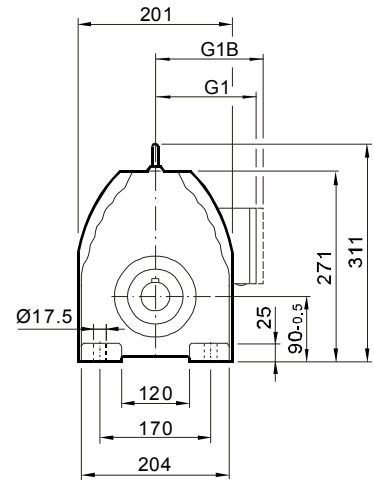
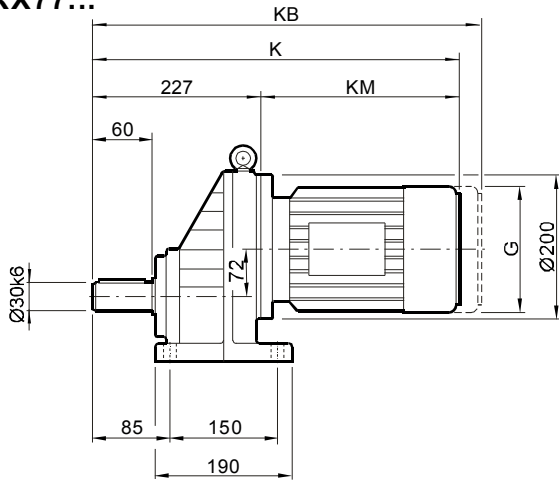

尺寸 Dimensions	电机规格 Motor frame										
	71	80	90	100M	100L	112M	132S	132M	160M	160L	180..
G	145	145	197	197	197	221	221	275	275	331	331
G1	122	122	154	166	166	176	176	230	230	259	253
G1B	127	127	161	166	166	182	182	230	230	259	253
K	420	470	526	576	606	609	654	676	736	783	855
KB	484	534	611	661	691	689	734	788	848	939	1011
KM	193	243	257	307	337	340	385	407	467	514	586

尺寸说明

以上尺寸为直联普通电机和制动电机尺寸；
G1B,KB为制动电机尺寸,其余为普通电机尺寸；
防爆电机, 辊道电机, 船用电机等须加过渡法兰, 见135页。

ATTENTION

Dimensions of general and brake motor shown in upon table, the others like explosion, roller, or marine motor coupled by adaptor, the dimensions on page 135.



安装尺寸

Mounting Dimensions

YRXF77...

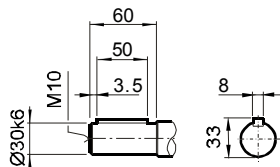
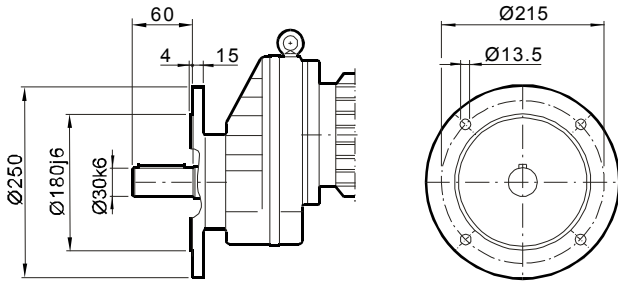
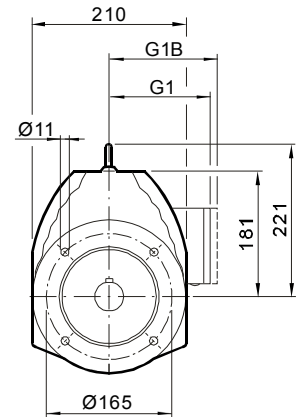
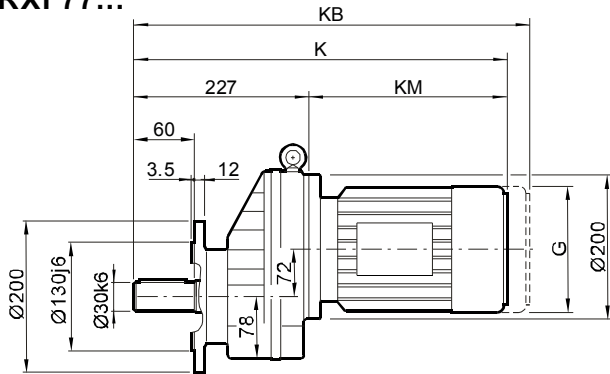

尺寸 Dimensions	电机规格 Motor frame									
	71	80	90	100M	100L	112M	132S	132M	160M	
G	145	145	197	197	197	221	221	275	275	
G1	122	122	154	166	166	176	176	230	230	
G1B	127	127	161	166	166	182	182	230	230	
K	420	470	488	538	568	572	617	639	699	
KB	484	534	573	623	653	652	697	751	811	
KM	193	243	261	311	341	345	390	412	472	

尺寸说明

以上尺寸为直联普通电机和制动电机尺寸；
G1B,KB为制动电机尺寸,其余为普通电机尺寸；
防爆电机，辊道电机，船用电机等须加过渡法兰，见135页。

ATTENTION

Dimensions of general and brake motor shown in upon table, the others like explosion, roller, or marine motor coupled by adaptor, the dimensions on page 135.



安装尺寸

Mounting Dimensions

YRX87...

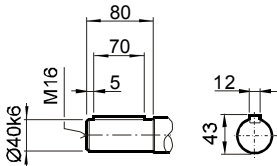
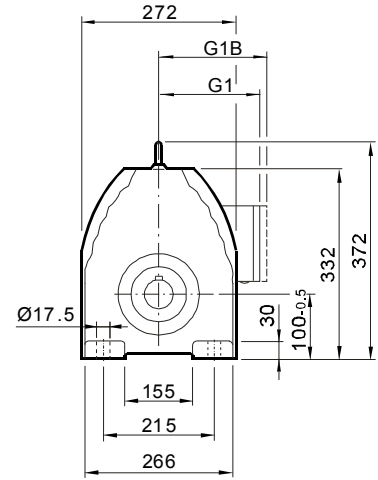
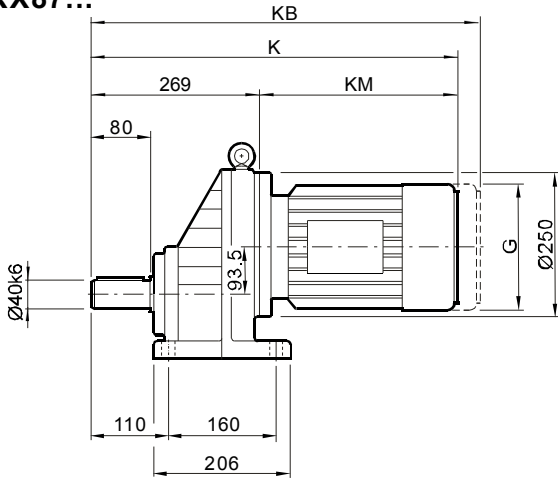

尺寸 Dimensions	电机规格 Motor frame									
	90	100M	100L	112M	132S	132M	160M	160L	180..	
G	197	197	197	221	221	275	275	331	331	
G1	154	166	166	176	176	230	230	259	253	
G1B	161	166	166	182	182	230	230	259	253	
K	526	576	606	609	654	676	736	783	855	
KB	611	661	691	689	734	788	848	939	1011	
KM	257	307	337	340	385	407	467	514	586	

尺寸说明

以上尺寸为直联普通电机和制动电机尺寸；
G1B,KB为制动电机尺寸,其余为普通电机尺寸；
防爆电机, 辊道电机, 船用电机等须加过渡法兰, 见135页。

ATTENTION

Dimensions of general and brake motor shown in upon table, the others like explosion, roller, or marine motor coupled by adaptor, the dimensions on page 135.



安装尺寸

Mounting Dimensions

YRXF87...

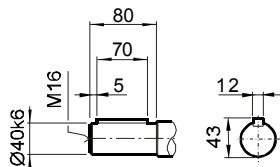
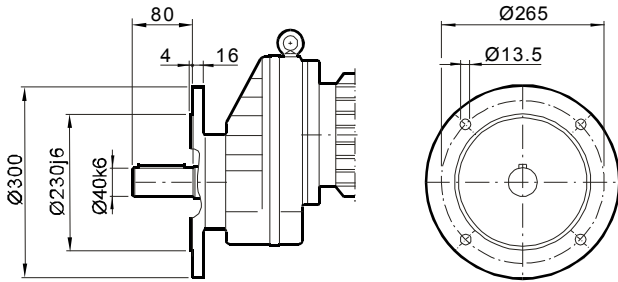
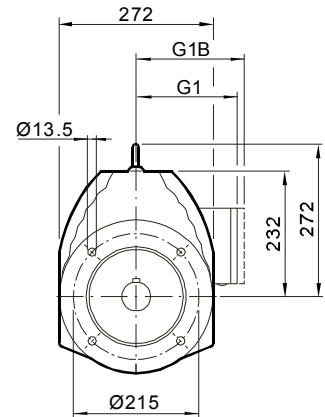
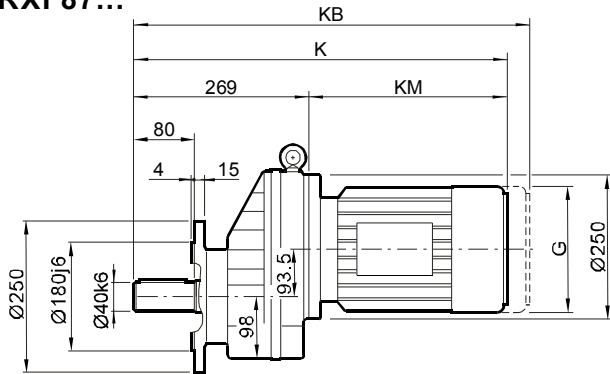

尺寸 Dimensions	电机规格 Motor frame									
	90	100M	100L	112M	132S	132M	160M	160L	180..	
G	197	197	197	221	221	275	275	331	331	
G1	154	166	166	176	176	230	230	259	253	
G1B	161	166	166	182	182	230	230	259	253	
K	526	576	606	609	654	676	736	783	855	
KB	611	661	691	689	734	788	848	939	1011	
KM	257	307	337	340	385	407	467	514	586	

尺寸说明

以上尺寸为直联普通电机和制动电机尺寸；
G1B,KB为制动电机尺寸,其余为普通电机尺寸；
防爆电机, 辊道电机, 船用电机等须加过渡法兰, 见135页。

ATTENTION

Dimensions of general and brake motor shown in upon table, the others like explosion, roller, or marine motor coupled by adaptor, the dimensions on page 135.



安装尺寸

Mounting Dimensions

YRX97...

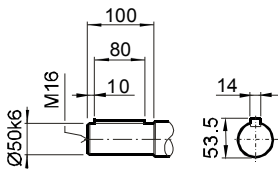
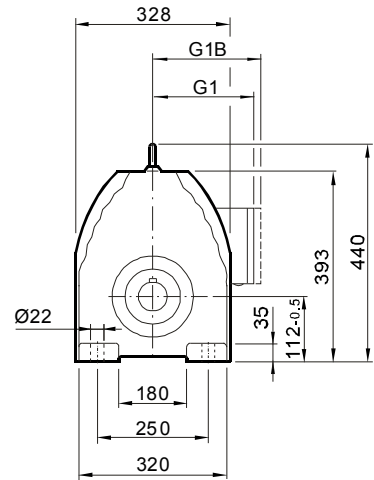
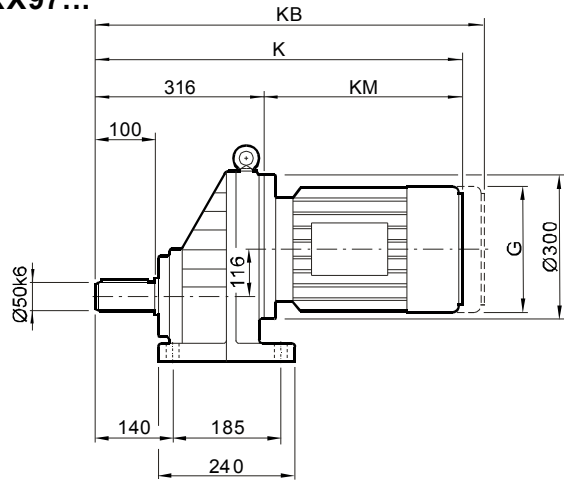

尺寸 Dimensions	电机规格 Motor frame										
	132S	132M	160M	160L	180..	200..					
G	221	275	275	331	331	394					
G1	176	230	230	259	253	285					
G1B	182	230	230	259	253	285					
K	696	718	778	825	897	945					
KB	776	830	890	981	1053	1101					
KM	380	402	462	509	581	629					

尺寸说明

以上尺寸为直联普通电机和制动电机尺寸；
G1B,KB为制动电机尺寸,其余为普通电机尺寸；
防爆电机，辊道电机，船用电机等须加过渡法兰，见135页。

ATTENTION

Dimensions of general and brake motor shown in upon table, the others like explosion, roller, or marine motor coupled by adaptor, the dimensions on page 135.



安装尺寸

Mounting Dimensions

YRXF97...

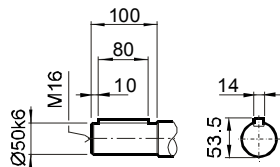
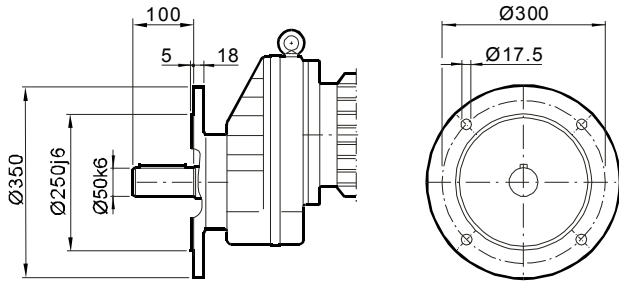
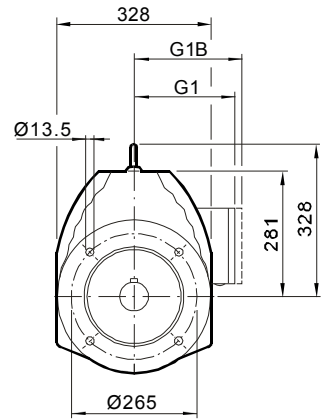
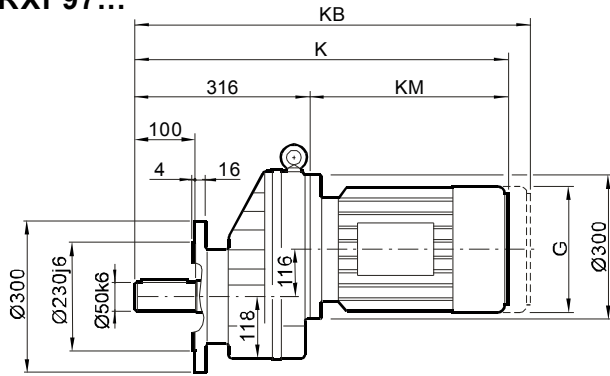

尺寸 Dimensions	电机规格 Motor frame									
	132S	132M	160M	160L	180..	200..				
G	221	275	275	331	331	394				
G1	176	230	230	259	253	285				
G1B	182	230	230	259	253	285				
K	696	718	778	825	897	945				
KB	776	830	890	981	1053	1101				
KM	380	402	462	509	581	629				

尺寸说明

以上尺寸为直联普通电机和制动电机尺寸；
G1B,KB为制动电机尺寸,其余为普通电机尺寸；
防爆电机，辊道电机，船用电机等须加过渡法兰，见135页。

ATTENTION

Dimensions of general and brake motor shown in upon table, the others like explosion, roller, or marine motor coupled by adaptor, the dimensions on page 135.



安装尺寸

Mounting Dimensions

YRX107...

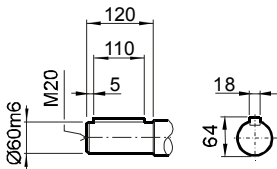
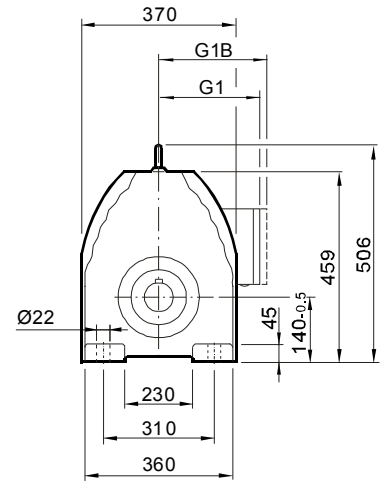
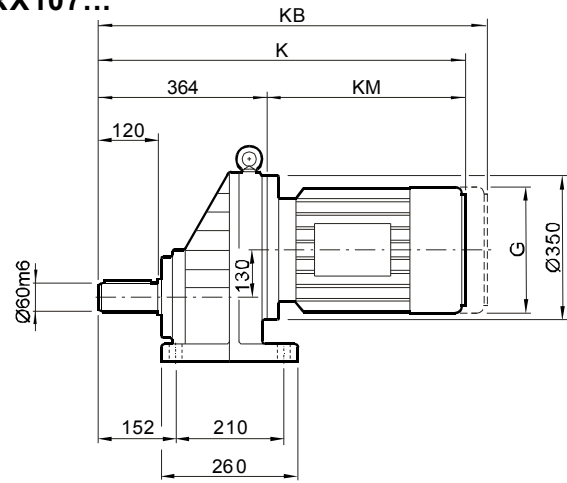

尺寸 Dimensions	电机规格 Motor frame								
	132S	132M	160M	160L	180..	200M	225..		
G	221	275	275	331	331	394	394		
G1	176	230	230	259	253	285	289		
G1B	127	230	230	259	253	285	289		
K	738	760	820	867	939	987	1069		
KB	818	872	932	1023	1095	1143	1225		
KM	374	396	456	503	575	623	705		

尺寸说明

以上尺寸为直联普通电机和制动电机尺寸；
G1B,KB为制动电机尺寸,其余为普通电机尺寸；
防爆电机, 辊道电机, 船用电机等须加过渡法兰, 见136页。

ATTENTION

Dimensions of general and brake motor shown in upon table, the others like explosion, roller, or marine motor coupled by adaptor, the dimensions on page 136.



安装尺寸

Mounting Dimensions

YRXF107...

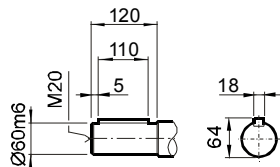
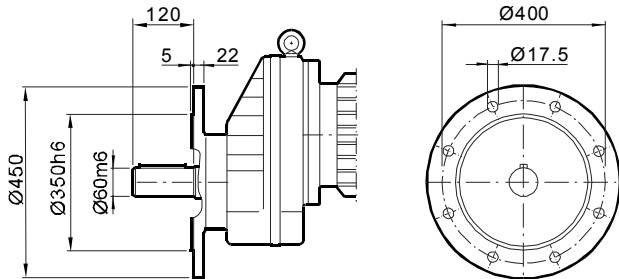
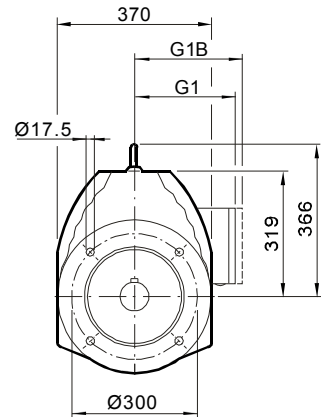
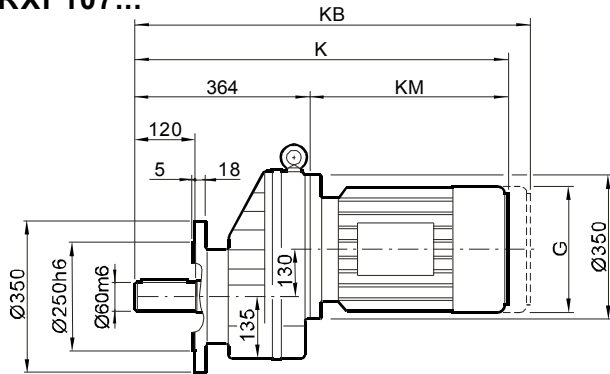

尺寸 Dimensions	电机规格 Motor frame								
	132S	132M	160M	160L	180..	200..	225..		
G	221	275	275	331	331	394	394		
G1	176	230	230	259	253	285	289		
G1B	182	230	230	259	253	285	289		
K	738	760	820	867	939	987	1069		
KB	818	872	932	1023	1095	1143	1225		
KM	374	396	456	503	575	623	705		

尺寸说明

以上尺寸为直联普通电机和制动电机尺寸；
G1B,KB为制动电机尺寸,其余为普通电机尺寸；
防爆电机, 辊道电机, 船用电机等须加过渡法兰, 见136页。

ATTENTION

Dimensions of general and brake motor shown in upon table, the others like explosion, roller, or marine motor coupled by adaptor, the dimensions on page 136.



安装尺寸

Mounting Dimensions

组合型尺寸

Combinations

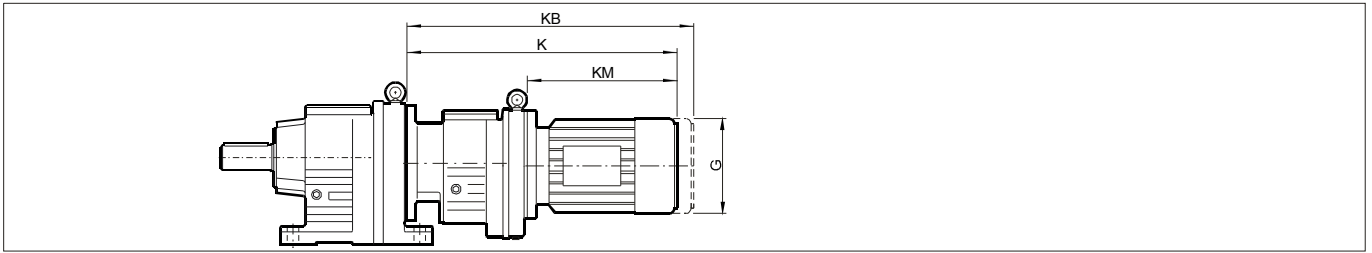

减速机规格 Gear unit size	电机规格 Motor frame	G	K	KB	KM
YR..27YR17 YR..37YR17	63..	132	338	395	163
	71..	145	339	403	164
	80..	145	389	453	214
YR..47YR37 YR..57YR37 YR..67YR37	63..	132	370	427	205
	71..	145	371	435	206
	80..	145	421	485	256
YR..77YR37	63..	132	362	419	205
	71..	145	363	427	206
	80..	145	413	477	256
	90..	197	433	518	276
YR..87YR57	63..	132	415	472	199
	71..	145	415	479	199
	80..	145	465	529	249
	90..	197	485	570	269
YR..97YR57	63..	132	410	467	199
	71..	145	410	474	199
	80..	145	460	524	249
	90..	197	480	565	269
	100L1	197	530	615	319
	100L2	197	560	645	349
YR..107YR77	63..	132	440	497	193
	71..	145	440	504	193
	80..	145	490	554	243
	90..	197	508	593	261
	100L1	197	558	643	311
	100L2	197	588	673	341
	112M	221	592	672	345
	132S	221	637	717	390
	132M	275	659	771	412
	160M	275	719	831	472
YR..137YR77	63..	132	433	490	193
	71..	145	433	497	193
	80..	145	483	547	243
	90..	197	501	586	261
	100L1	197	551	636	311
	100L2	197	581	666	341
	112M	221	585	665	345
	132S	221	630	710	390
	132M	275	652	764	412
	160M	275	712	824	472

减速机规格 Gear unit size	电机规格 Motor frame	G	K	KB	KM
YR..147YR77	63..	132	425	482	193
	71..	145	425	489	193
	80..	145	475	539	243
	90..	197	493	578	261
	100L1	197	543	628	311
	100L2	197	573	658	341
	112M	221	577	657	345
	132S	221	622	702	390
	132M	275	644	756	472
	160M	275	704	816	472
YR..147YR87	90..	197	537	622	257
	100L1	197	587	672	307
	100L2	197	617	702	337
	112M	221	620	700	340
	132S	221	665	745	385
	132M	275	687	799	407
	160M	275	747	859	467
	160L	331	794	950	514
	180..	331	866	1022	586
	YR..167YR97	80..	145	556	620
90..		197	576	661	251
100L1		197	626	711	301
100L2		197	656	741	331
112M		221	660	740	335
132S		221	705	785	380
132M		275	727	839	402
160M		275	787	899	462
160L		331	834	990	509
180..		331	906	1062	581
YR..167YR107	100L1	197	677	762	295
	100L2	197	707	792	325
	112M	221	711	791	329
	132S	221	756	836	374
	132M	275	778	890	396
	160M	275	838	950	456
	160L	331	885	1041	456
	180..	331	957	1113	503
	200..	394	1005	1161	575
	225..	394	1087	1243	623

其它未注尺寸请参考相关机型号

Dimensions is not indicated, please refer to correlative gear unit size



安装尺寸

Mounting Dimensions

联结法兰尺寸

Adapter dimensions

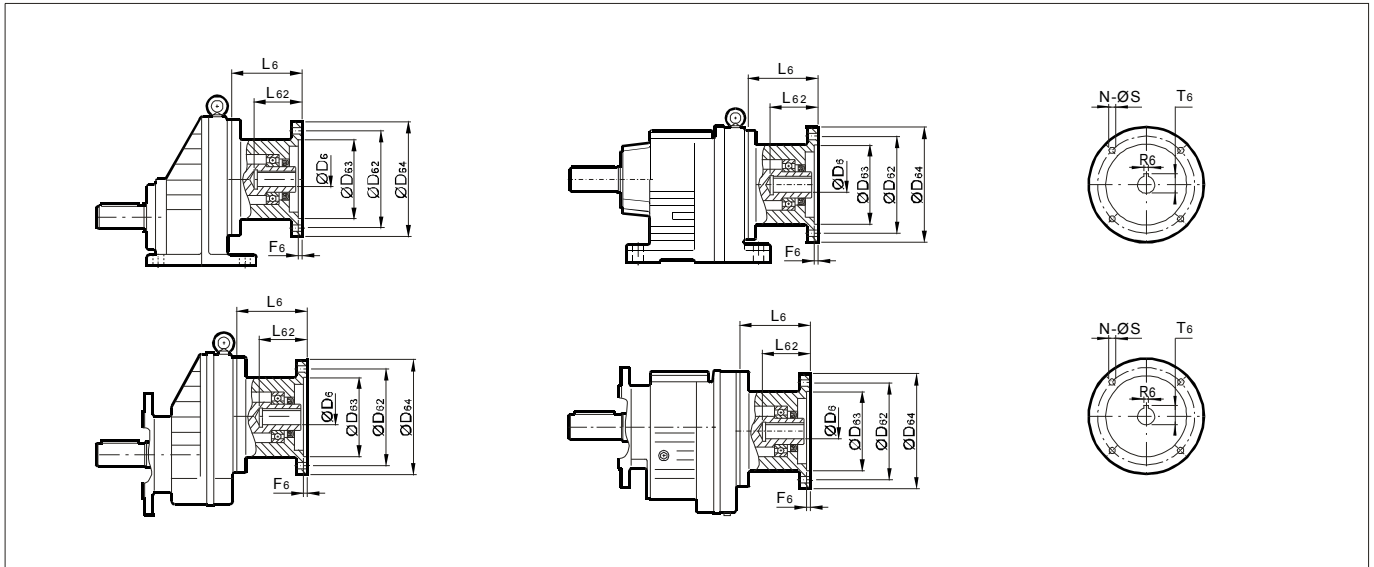

减速机型号 Gear unit size	法兰规格 Motor frame	D ₆	T ₆	R ₆	F ₆	L ₆	L ₆₂	D ₆₄	D ₆₂	D ₆₃	N	S
YR..27 YR..37	63B5	11	12.8	4	3.5	83	26	140	115	95	4	10
	71B5	14	16.3	5	3.5	83	33	160	130	110	4	10
	80B5	19	21.8	6	4.5	103	43	200	165	130	4	12
	90B5	24	27.3	8	4.5	103	53	200	165	130	4	12
YR..47 YR..57 YR..67	63B5	11	12.8	4	3.5	83	26	140	115	95	4	10
	71B5	14	16.3	5	3.5	83	33	160	130	110	4	10
	80B5	19	21.8	6	4.5	103	43	200	165	130	4	12
	90B5	24	27.3	8	4.5	103	53	200	165	130	4	12
	100B5	28	31.3	8	5	110	63	250	215	180	4	15
	112B5	28	31.3	8	5	110	63	250	215	180	4	15
YR..77	63B5	11	12.8	4	3.5	83	26	140	115	95	4	10
	71B5	14	16.3	5	3.5	83	33	160	130	110	4	10
	80B5	19	21.8	6	4.5	103	43	200	165	130	4	12
	90B5	24	27.3	8	4.5	103	53	200	165	130	4	12
	100B5	28	31.3	8	5	110	63	250	215	180	4	15
	112B5	28	31.3	8	5	110	63	250	215	180	4	15
	132B5	38	41.3	10	5	133	85	300	265	230	4	15
YR..87	80B5	19	21.8	6	4.5	103	43	200	165	130	4	12
	90B5	24	27.3	8	4.5	103	53	200	165	130	4	12
	100B5	28	31.3	8	5	110	63	250	215	180	4	15
	112B5	28	31.3	8	5	110	63	250	215	180	4	15
	132B5	38	41.3	10	5	133	85	300	265	230	4	15
	160B5	42	45.3	12	6	171	115	350	300	250	4	19
YR..97	100B5	28	31.3	8	5	110	63	250	215	180	4	15
	112B5	28	31.3	8	5	110	63	250	215	180	4	15
	132B5	38	41.3	10	5	133	85	300	265	230	4	15
	160B5	42	45.3	12	6	171	115	350	300	250	4	19
	180B5	48	51.8	14	6	171	115	350	300	250	4	19
	200B5	55	59.3	16	7	171	115	400	350	300	4	19
225B5	60	64.4	18	7	215	145	450	400	350	8	19	



安装尺寸

Mounting Dimensions

联结法兰尺寸

Adapter Dimensions

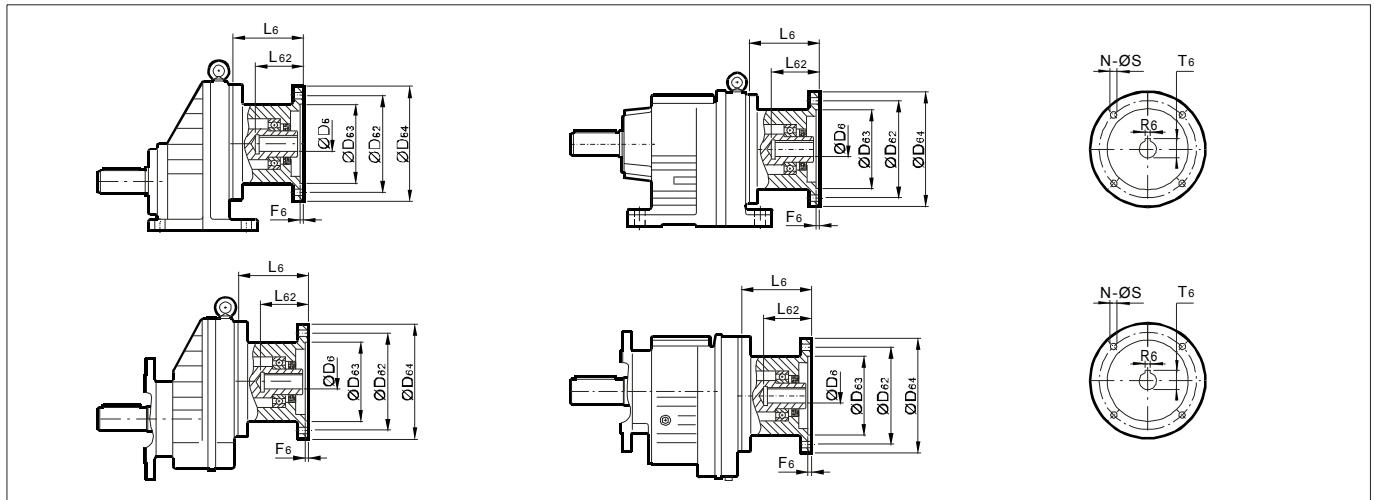

减速机型号 Gear unit size	法兰规格 Motor frame	D ₆	T ₆	R ₆	F ₆	L ₆	L ₆₂	D ₆₄	D ₆₂	D ₆₃	N	S
YR..107	100B5	28	31.3	8	5	110	63	250	215	180	4	15
	112B5	28	31.3	8	5	110	63	250	215	180	4	15
	132B5	38	41.3	10	5	133	85	300	265	230	4	15
	160B5	42	45.3	12	6	171	115	350	300	250	4	19
	180B5	48	51.8	14	6	171	115	350	300	250	4	19
	200B5	55	59.3	16	7	171	115	400	350	300	4	19
YR..137	225B5	60	64.4	18	7	215	145	450	400	350	8	19
	132B5	38	41.3	10	5	133	85	300	265	230	4	15
	160B5	42	45.3	12	6	171	115	350	300	250	4	19
	180B5	48	51.8	14	6	171	115	350	300	250	4	19
	200B5	55	59.3	16	7	171	115	400	350	300	4	19
YR..147	225B5	60	64.4	18	7	215	145	450	400	350	8	19
	132B5	38	41.3	10	5	133	85	300	265	230	4	15
	160B5	42	45.3	12	6	171	115	350	300	250	4	19
	180B5	48	51.8	14	6	171	115	350	300	250	4	19
	200B5	55	59.3	16	7	171	115	400	350	300	4	19
	225B5	60	64.4	18	7	215	145	450	400	350	8	19
YR..167	250B5	65	69.4	18	7	215	145	550	500	450	8	19
	280B5	75	79.9	20	7	215	145	550	500	450	8	19
	132B5	38	41.3	10	5	133	85	300	265	230	4	15
	160B5	42	45.3	12	6	171	115	350	300	250	4	19
	180B5	48	51.8	14	6	171	115	350	300	250	4	19
	200B5	55	59.3	16	7	171	115	400	350	300	4	19

注意!

- 1 选用底脚安装减速机时, 尺寸ØD64可能会超过底脚安装面, 请注意校核。
- 2 适配电机参照IEC B5法兰规格, 其它未注尺寸请参考相关机型号。

Attention!

- 1 Dimension Ø D64 may protrude past foot mounting surface if selecting foot-mounted type.
- 2 the motor flange follow IEC B5 type, dimensions is not indicated, please refer to correlative gear unit size



安装尺寸

Mounting dimensions

输入轴尺寸

Input Shaft Dimensions

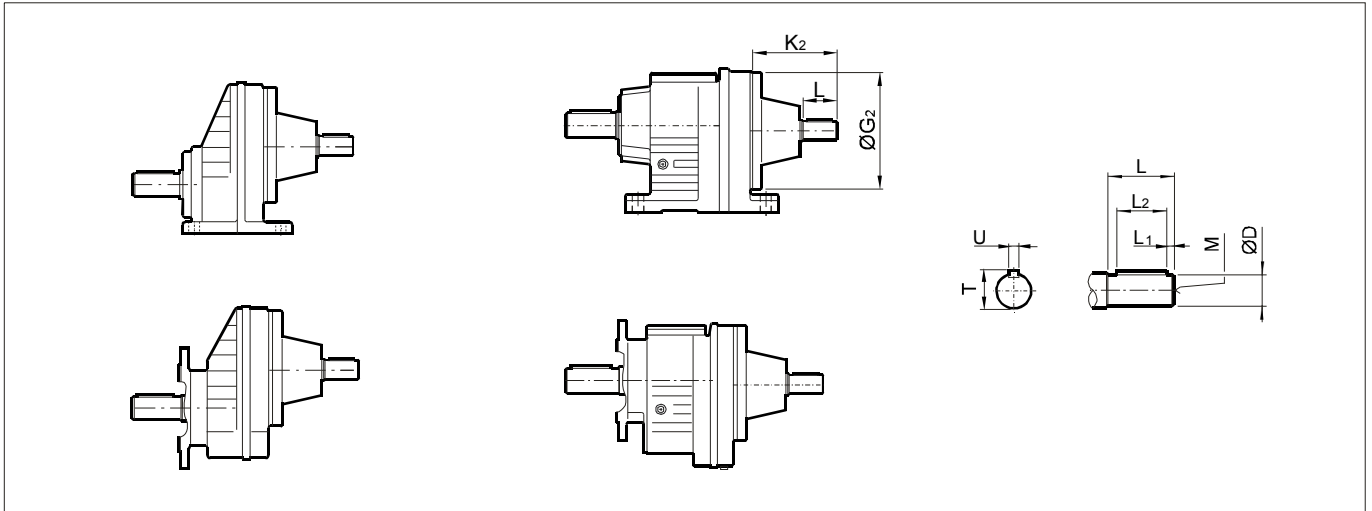

减速机型号 Gear unit size	D	G ₂	K ₂	L	M	L ₁	L ₂	T	U
YR..37S	16k6	120	115	40	M5	4	32	18	5
YR..47S	19k6	160	120	40	M6	4	32	21.5	6
YR..57S	19k6	160	120	40	M6	4	32	21.5	6
YR..67S	19k6	160	120	40	M6	4	32	21.5	6
YR..77S	24k6	200	140	50	M8	5	40	27	8
YR..87S	28k6	250	180	60	M10	5	50	31	8
YR..97S	38k6	300	220	80	M12	5	50	41	10
YR..107S	42k6	350	270	110	M16	10	70	45	12
YR..137S	55m6	400	297	110	M20	10	90	59	16
YR..147S	55m6	450	297	110	M20	10	90	59	16
YR..167S	70m6	550	374	140	M20	15	110	74.5	20

注意！

其它未注尺寸请参考相关机型号。

Attention!

Dimensions is not indicated, please refer to correlative gear unit size



RM型减速机

RM Gear Units

设计说明

YRM型减速机在普通减速机的基础上，专为搅拌器延伸设计，技术参数参照其它同型号减速机。

选型程序流程图

选用RM型带轴承室减速机时，应考虑径向和轴向载荷。请按后面的程序流程图选用：

a = 表中变量

b = 表中变量

C_F = 表中减速机常量

F_a = 运行轴向力

F_F = 表中减速机常量

F_R = 运行径向载荷

F_{Ra} = 表中许用径向载荷($x=1000mm$)

F_{XF} = 减速机法兰许用径向载荷

F_{XL} = 在设计寿命内的轴承室许用径向载荷

X = 力作用点到轴肩的距离

M_2 = 减速机输出转矩

F_{Aa} = 许用轴向力

Gear Unit Introduce

YRM series gear unit base on conventional gear unit extension, design for mixer, the technical data see correlative size.

Project Planning

radial and axial loads should be considered when planning projects with RM helical gear unit with bearing housing. Please adhere to the following project planning procedure:

a = conversion factor from data table

b = conversion factor from data table

C_F = gear unit constants from data table

F_a = axial loads during operation

F_F = gear unit constants from data table

F_R = radial loads during operation

F_{Ra} = permissible radial load(at $x=1000mm$)

from the data table

F_{XF} = permissible radial load on the housing (flange tensile strength)

F_{XL} = permissible radial load according to bearing service life

X = distance between force application and shaft shoulder

M_2 = output torque of gear unit

F_{Aa} = permissible axial load

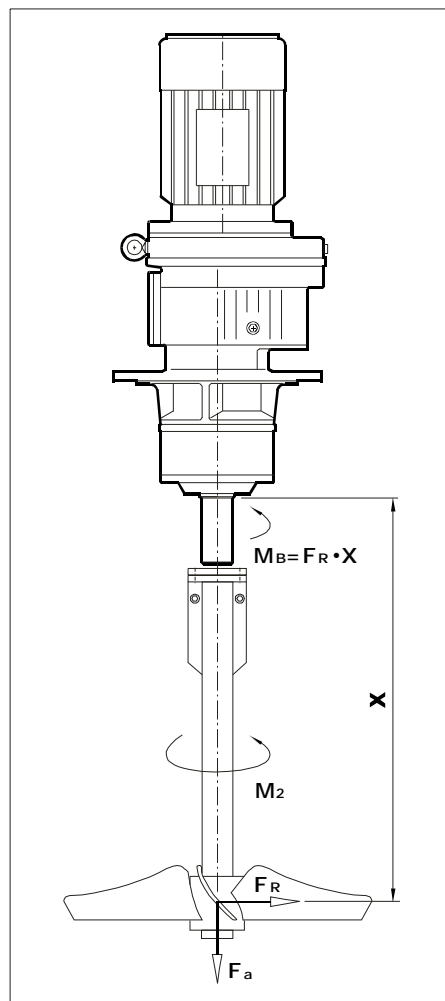



RM型减速机

选型程序流程图

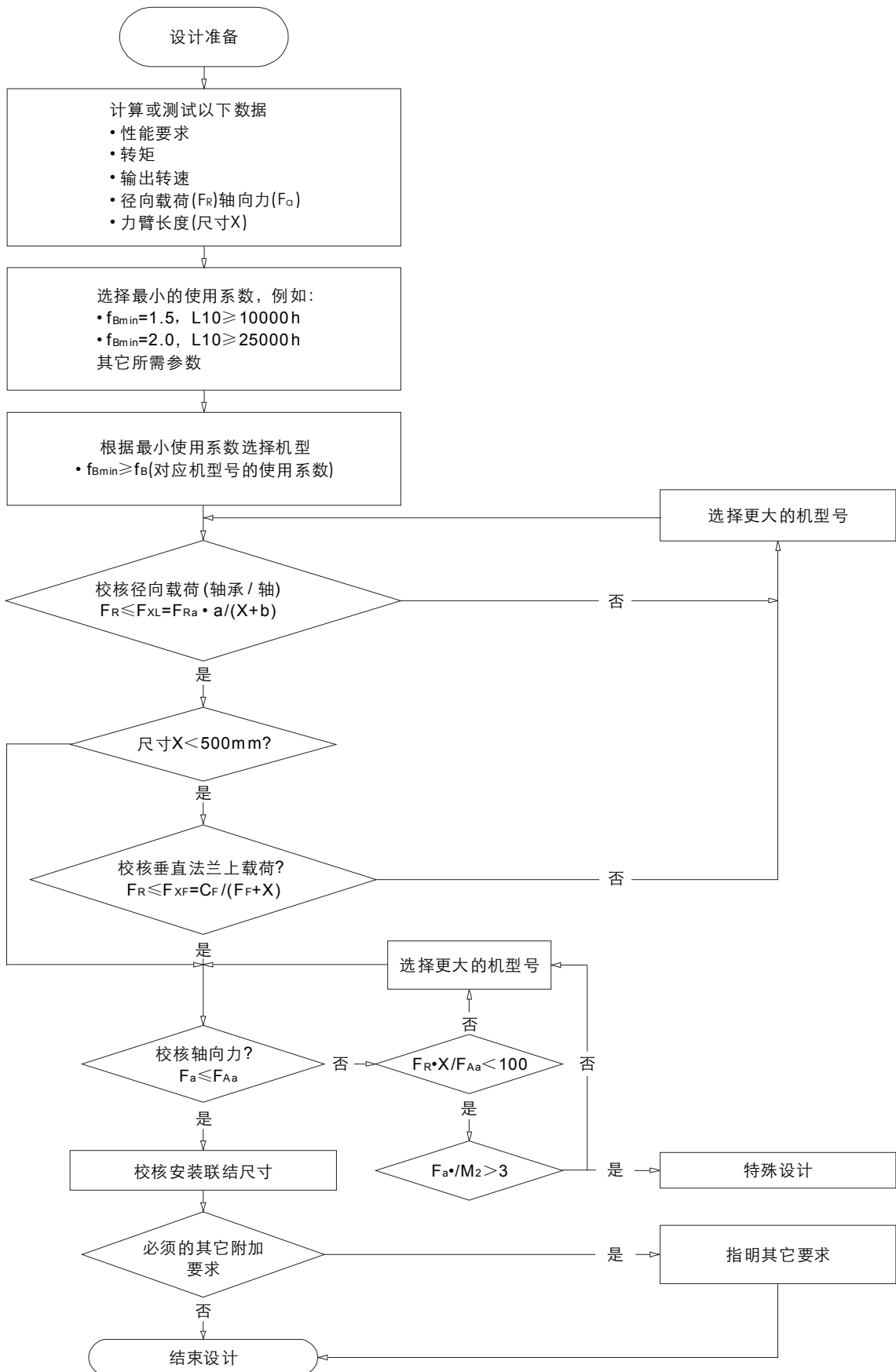



YRM Gear Units

Gear Unit Introduce

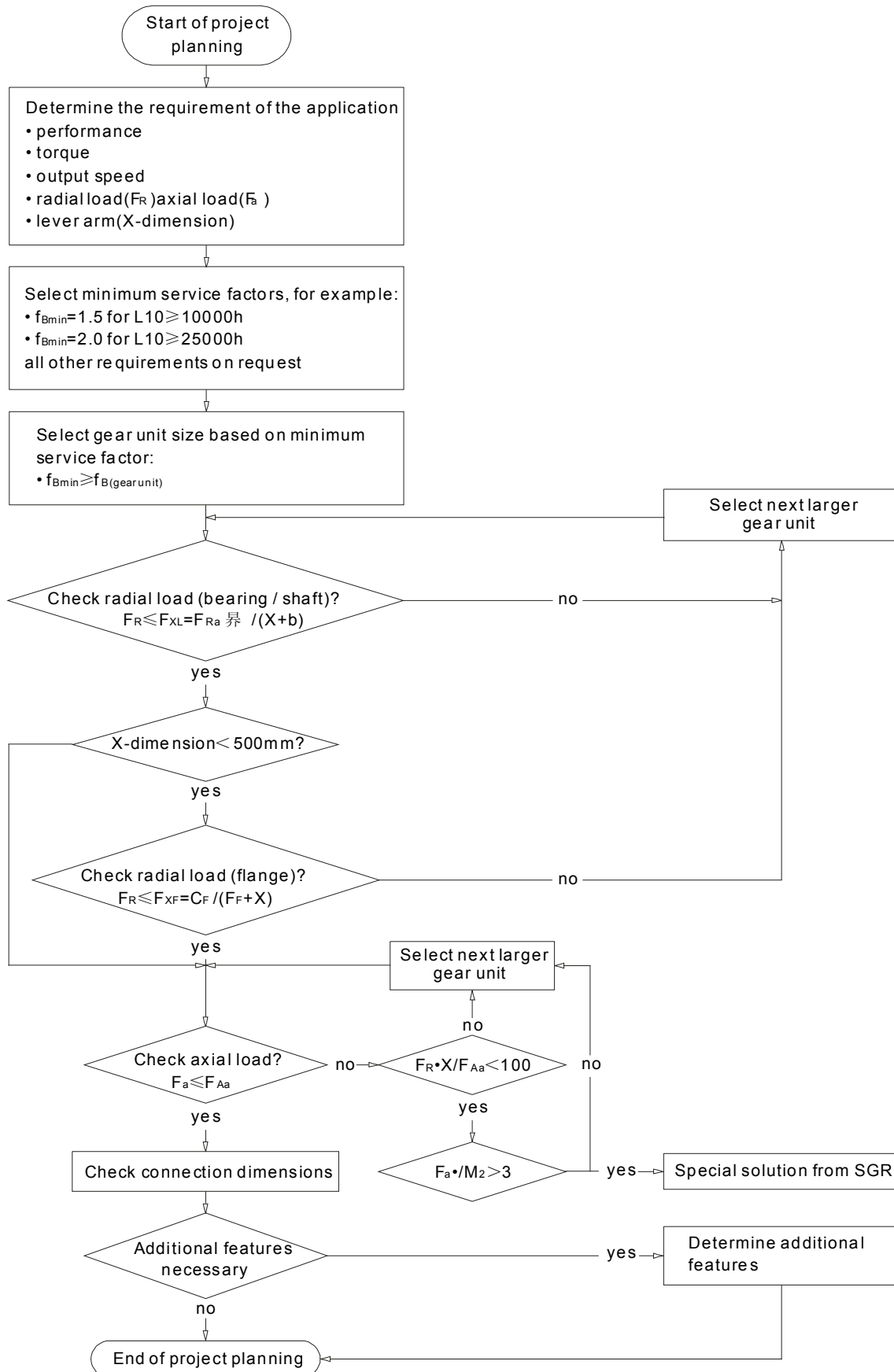



YRM型减速机

YRM Gear Units

径向力 F_{Ra} 及轴向力 F_{Aa}

Radial Loads F_{Ra} and Axial Loads F_{Aa}

Na [rpm]		$F_{Bmin}=1.5 \quad L_{10h}=10000h$							
		<16	16~25	26~40	41~60	61~100	101~160	161~250	251~400
YRM57	F_{Ra}	400	400	400	400	400	405	410	415
	F_{Aa}	18800	18800	11500	9700	7100	5650	4450	3800
YRM67	F_{Ra}	575	575	575	580	575	585	590	600
	F_{Aa}	19000	19000	15300	11900	9210	7470	5870	5050
YRM77	F_{Ra}	1200	1200	1200	1200	1200	1210	1210	1220
	F_{Aa}	22000	22000	19400	15100	11400	9220	7200	6710
YRM87	F_{Ra}	1970	1970	1970	1970	1980	1990	2000	2010
	F_{Aa}	30000	30000	23600	18000	14300	11000	8940	8030
YRM97	F_{Ra}	2980	2980	2980	2990	3010	3050	3060	3080
	F_{Aa}	40000	40000	27300	20300	15900	12600	9640	7810
YRM107	F_{Ra}	4230	4230	4230	4230	4230	4230	3580	3830
	F_{Aa}	48000	48000	30300	23000	18000	13100	9550	9030
YRM137	F_{Ra}	8710	8710	8710	8710	7220	5060	3980	6750
	F_{Aa}	70000	70000	70000	57600	46900	44000	35600	32400
YRM147	F_{Ra}	11100	11100	11100	11100	11100	10600	8640	10800
	F_{Aa}	70000	70000	69700	58400	45600	38000	32800	30800
YRM167	F_{Ra}	14600	14600	14600	14600	14600	14700	-	-
	F_{Aa}	70000	70000	70000	60300	45300	36900	-	-

Na [rpm]		$F_{Bmin}=2 \quad L_{10h}=25000h$							
		<16	16~25	26~40	41~60	61~100	101~160	161~250	251~400
YRM57	F_{Ra}	410	410	410	410	410	415	415	420
	F_{Aa}	12100	9600	7350	6050	4300	3350	2600	2200
YRM67	F_{Ra}	590	590	590	595	590	595	600	605
	F_{Aa}	15800	12000	9580	7330	5580	4460	3460	2930
YRM77	F_{Ra}	1210	1210	1210	1210	1210	1220	1220	1220
	F_{Aa}	20000	15400	11900	9070	6670	5280	4010	3700
YRM87	F_{Ra}	2000	2000	2000	2000	2000	1720	1690	1710
	F_{Aa}	24600	19200	14300	10600	8190	6100	5490	4860
YRM97	F_{Ra}	3040	3040	3040	3050	3070	3080	2540	2430
	F_{Aa}	28400	22000	16200	11600	8850	6840	5830	4760
YRM107	F_{Ra}	4330	4330	4330	4330	4330	3350	2810	2990
	F_{Aa}	32300	24800	17800	13000	9780	8170	5950	5620
YRM137	F_{Ra}	8850	8850	8850	8830	5660	4020	3200	5240
	F_{Aa}	70000	59900	48000	37900	33800	31700	25600	23300
YRM147	F_{Ra}	11400	11400	11400	11400	11400	8320	6850	8440
	F_{Aa}	70000	60600	45900	39000	33500	27900	24100	22600
YRM167	F_{Ra}	15100	15100	15100	15100	15100	13100	-	-
	F_{Aa}	70000	63500	51600	37800	26800	23600	-	-



YRM型减速机

YRM Gear Units

变量和减速机常数

当 $X \neq 1000\text{mm}$ 时，计算YRM型减速机许用径向力 F_{rL} 所用的变量和常数。

Conversion Factor and Gear Unit constants

The following conversion factors and gear unit constants apply to calculating permitted load F_{rL} at point $X \neq 1000\text{mm}$ for YRM gear units.

减速机型号 Gear unit type	a	b	$C_F(f_B=1.5)$	$C_F(f_B=2.0)$	F_F
YRM57	1047	47	1220600	1260400	277
YRM67	1047	47	2047600	2100000	297.5
YRM77	1050	50	2512800	2574700	340.5
YRM87	1056.5	56.5	4917800	5029000	414
YRM97	1061	61	10911600	11124100	481
YRM107	1069	69	15367000	15652000	554.5
YRM137	1088	88	25291700	25993600	650
YRM147	1091	91	30038700	31173900	756
YRM167	1089.5	89.5	42096100	43654300	869

YRM型减速机相对于YRF型减速机，轴承室增加重量

Additional Weights of YRM Gear Unit Bearing Housing

减速机型号 Gear unit type	$\Delta m[\text{kg}]$
YRM57	12.0
YRM67	15.8
YRM77	25.0
YRM87	29.7
YRM97	51.3
YRM107	88.0
YRM137	111.1
YRM147	167.4
YRM167	195.4

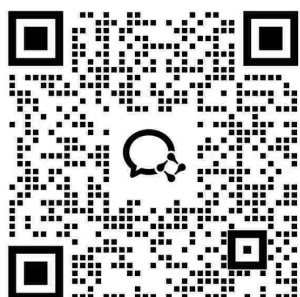

添加企业微信



微信选型小程序



注：有关本产品的内容，随着技术进步等，将会有变更，不另行通知，望谅解！