



目录	页面	Contents	Page
----	----	----------	------

**YF系列平行轴斜齿轮减速机**

产品外形	144-144
型号标记	145-145
电机配置说明	145-146
安装位置	147-148
技术参数	149-201
安装尺寸	202-245

**YF Series Parallel Shaft Gear Motor**

Products Figure	144-144
Designation	145-145
Configuration	145-146
Mounting Position	147-148
Technical Data	149-201
Mounting Dimensions	202-245

YF系列结构图

YF series structure drawing

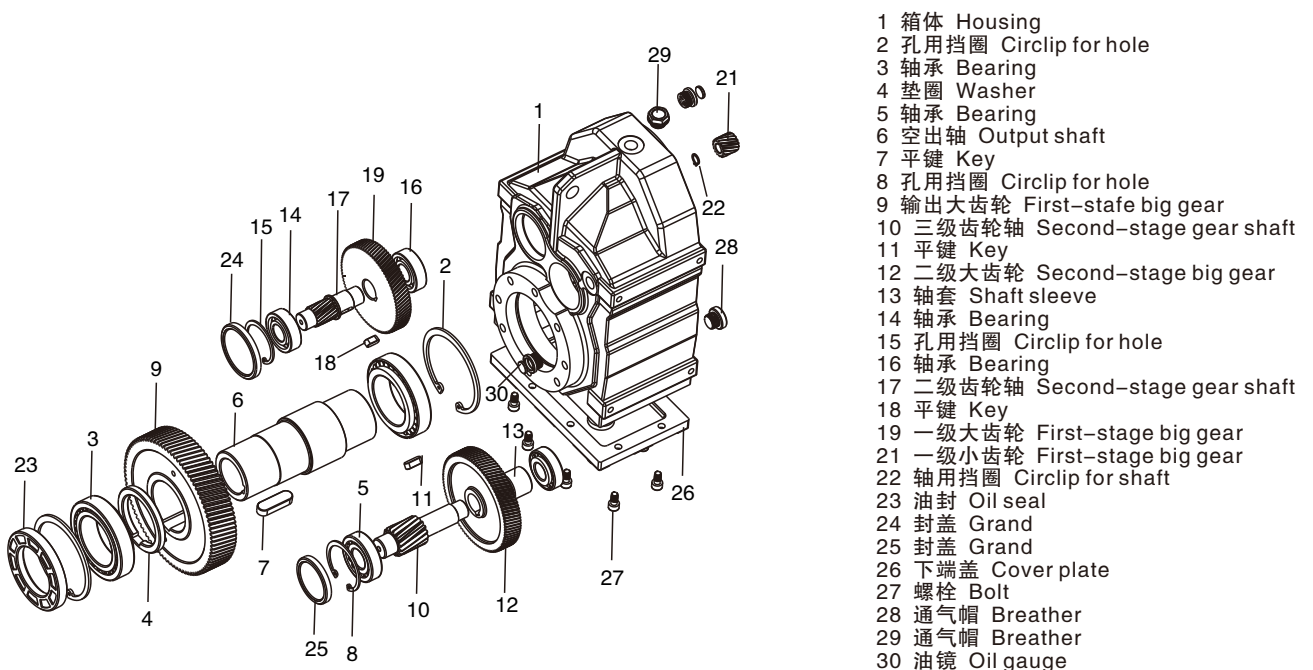



产品外形

Products Figure

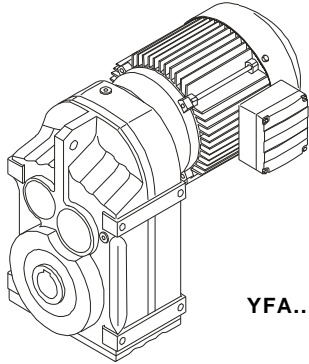

YFA..

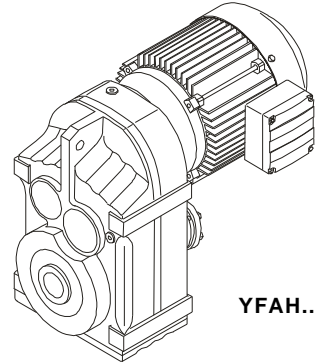

YFAH..

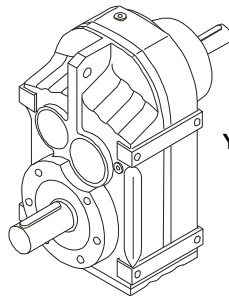

YF..S..

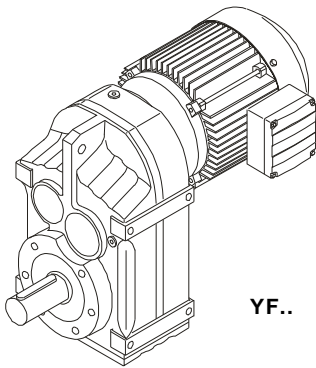

YF..

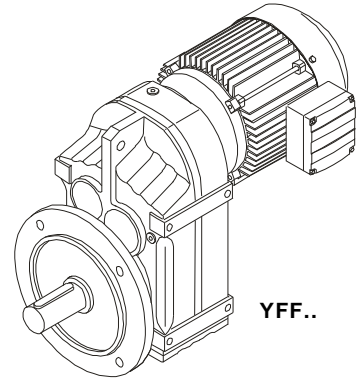

YFF..

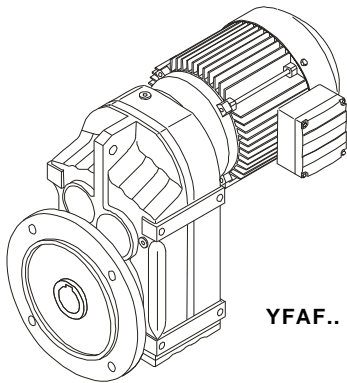

YFAF..

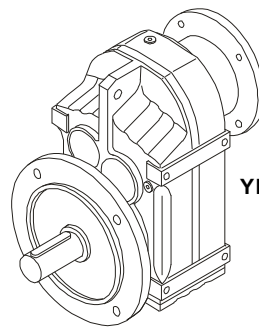

YF..B5

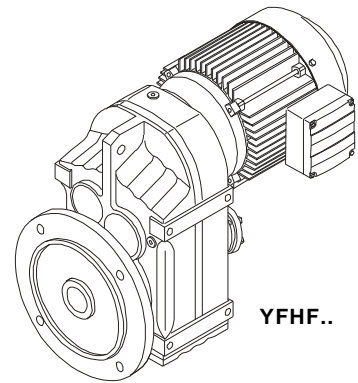

YFHF..

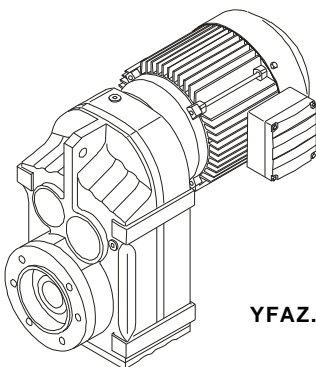

YFAZ..

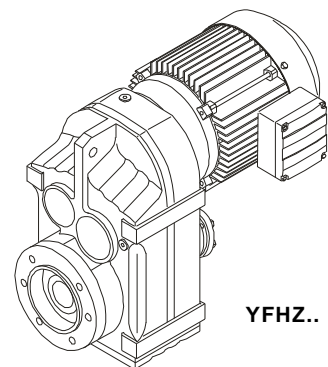

YFHZ..



## 型号标记

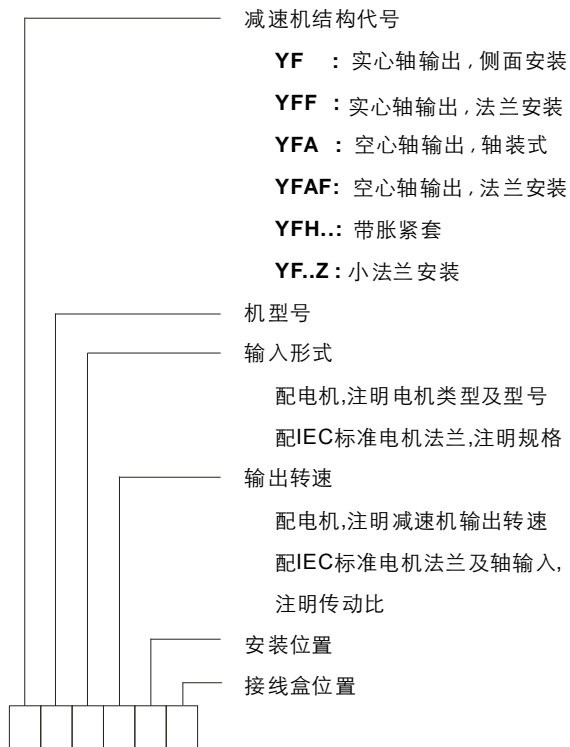

### 标记示例

#### A YFA77Y100L1-4NA39M1-270

输出空心孔定位, 孔铰接安装, 机型号77, 电机规格Y100L1-4, 输出转速39rpm, 安装位置M1, 电机接线盒位置270°

#### B YFA77BY100L1-4NA39M1-270

侧面螺纹孔安装, 空心孔输出, 机型号77, 电机规格Y100L1-4, 输出转速39rpm, 安装位置M1, 电机接线盒位置270°

#### C YFHF77YB100L1-4NA39M1-270 (dII BT4, IP54/F)

法兰安装, 空心孔带胀紧套输出, 机型号77, 防爆电机YB100L1-4 防爆等级dII BT4, 防护等级IP54, 绝缘等级F, 输出转速39rpm, 安装位置M1, 电机接线盒位置270°

## 电机配置说明

### Y系列普通三相异步电机

- 1 本系列减速机标准配置Y系列普通三相异步感应电机;
- 2 电机电压: 380V/50Hz;
- 3 电机防护等级IP54, 绝缘等级F, B级温升;
- 4 环境温度不超过40℃, 不低于-15℃;
- 5 连续工作制S1;
- 6 海拔高度不超过1000m;

## Designation

### gear unit structure

- YF** : solid shaft, rail-mounted  
**YFF** : solid shaft, flange-mounted  
**YFA** : hollow shaft with key, shaft-mounted  
**YFAF**: hollow shaft with key, flange-mounted  
**YFH..**: with shrink disk  
**YF..Z** : small flange mounting

### gear unit size

#### input structure:

- connect with motor, indicate motor model  
connect with IEC flange, indicate frame

#### output speed

- connect with motor, indicate output speed  
connect with IEC flange or with input shaft,  
indicate ratio

#### mounting position

#### terminal box position

### Sign Example

#### A YFA77Y100L1-4NA39M1-270

hollow shaft mounted with ream hole, gear unit size 47, motor frame Y100L1-4, output speed 39 rpm, mounting position M1, terminal box 270°

#### B YFA77BY100L1-4NA39M1-2

70 rail mounted with tapped holes, hollow shaft output, gear unit size 77, motor frame Y100L1-4, output speed 39rpm, mounting position M1, terminal box 270

#### C YFHF77YB100L1-4NA39M1-270 (dII BT4, IP54/F)

flange mounted, hollow shaft with shrink disc, gear unit size 77, exproof motor frame 100L1-4, protection IP54/F, output speed 39rpm, mounting position M1, terminal box 270

## Configuration of Electric Motor

### Y series Three-phase Asynchronous Electric Motor

- 1 this series gear unit configure three-phase asynchronous electric motor;
- 2 voltage: 380V/50Hz;
- 3 protection class: IP54, insulation class: F; temperature rising class: B;
- 4 ambient temperature: -15~40C ;
- 5 continue working duty: S1;
- 6 altitude less than 1000m;



## 电机配置说明

## Configuration of Electric Motor

### Y系列普通三相异步电机

- 7 冷却方式为C0141（风扇自冷）；
- 8 100及以下规格为"Y"接法，112M及以上规格为"Δ"接法；
- 9 优先选用 4, 6, 8极电机，2极电机不推荐使用；
- 10 电机技术参数见第433-438页

### Y series Three-phase Asynchronous Electric Motor

- 7 self-cooling with fan:C0141;
- 8 within frame 100, follow connection Y, from frame 112, follow connection Δ;
- 9 first select 4,6,8 poles motor;
- 10 technical data on page 433-438.

### YEJ系列三相异步制动电机

- 1 三相异步制动电机为普通电机的基础上附加制动器；
- 2 电机电压：380V/50Hz；
- 3 制动器电压：规格71~100: DC99V  
规格112~200: DC170V
- 4 配置单相AC220/50Hz整流器；
- 5 电机防护等级IP44，绝缘等级F, B级温升；
- 6 环境温度不超过40℃,不低于-15℃；
- 7 连续工作制S1；
- 8 海拔高度不超过1000m；
- 9 冷却方式为C0141（风扇自冷）；
- 10 100及以下规格为"Y"接法，112M及以上规格为"Δ"接法；
- 11 优先选用 4, 6, 8极电机，2极电机不推荐使用。
- 12 电机技术参数见第433-438页

### YEJ series Three-phase Asynchronous Brake Motor

- 1 base on Y series motor, add a brake.
- 2 voltage:380V/50Hz;
- 3 brake voltage: frame:71~100 DC99V  
frame:112~200 DC170V;
- 4 with single phase AC220V/50Hz rectifier;
- 5 protection class:IP54,insulation class: F, temperature rising class: B;
- 6 ambient temperature:-15~40C ;
- 7 continue working duty:S1;
- 8 altitude less than 1000m;
- 9 self-cooling with fan:C0141;
- 10 within frame 100, follow connection Y, from frame 112, follow connection Δ;
- 11 first select 4,6,8 poles motor;
- 12 technical data on page 433-438.

### YVF系列三相异步变频电机

- 1 电机电压：380V；
- 2 基准频率：50Hz；
- 3 允许调频5~50Hz，恒转矩调速；
- 4 电机防护等级IP54，绝缘等级F, B级温升；
- 5 环境温度不超过40℃,不低于-15℃；
- 6 连续工作制S1；
- 7 海拔高度不超过1000m；
- 8 冷却方式为C416（独立风扇）；
- 9 接线方式按适配变频器要求；
- 10 优先选用 4极电机。

### YVF series Three-phase Variable-frequency Motor

- 1 voltage:380V;
- 2 rated frequency 50Hz;
- 3 available frequency:5~50Hz;
- 4 protection class:IP54,insulation class: F, temperature rising class:B;
- 5 ambient temperature:-15~40C ;
- 6 continue working duty:S1;
- 7 altitude less than 1000m;
- 8 cooling with independence fan:C416;
- 9 connection perform the requirement of inverter;
- 10 first select 4 poles motor;

### 特殊电机

- 1 选用包括防爆电机，辊道电机，船用电机，多速电机等特殊电机，本公司提供IEC标准电机法兰接口，接口尺寸见243-244页；
- 2 异频率，异电压电机，请联系本公司技术部；
- 3 使用环境温度不在-15~40℃范围内，请联系本公司技术部；
- 4 更高的绝缘等级及防护等级，请联系本公司技术部。

### Customized Motor

- 1 others like explosion proof, roller motor, marine motor or multi-speed motor coupled by adaptor, the dimensions on page 243-244.
- 2 need different frequency and voltage, please contact us.
- 3 ambient temperature is not in -15~40C ,please contact us.
- 4 for higher insulation and protection class,please contact us.



### 安装位置

### Mounting Position

YF, YFA, YFAH, YFAZ 减速机安装位置

YF, YFA, YFAH, YFAZ Gear Unit Mounting Position

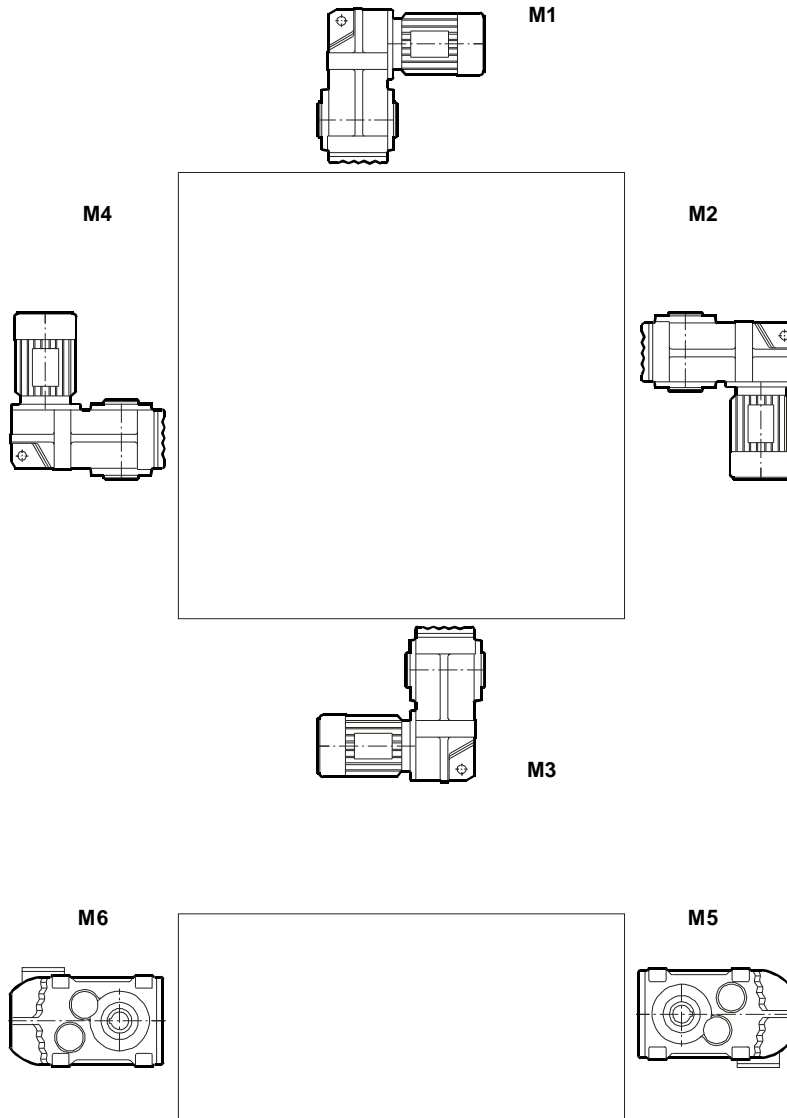

### 接线盒位置

### Terminal Box Position

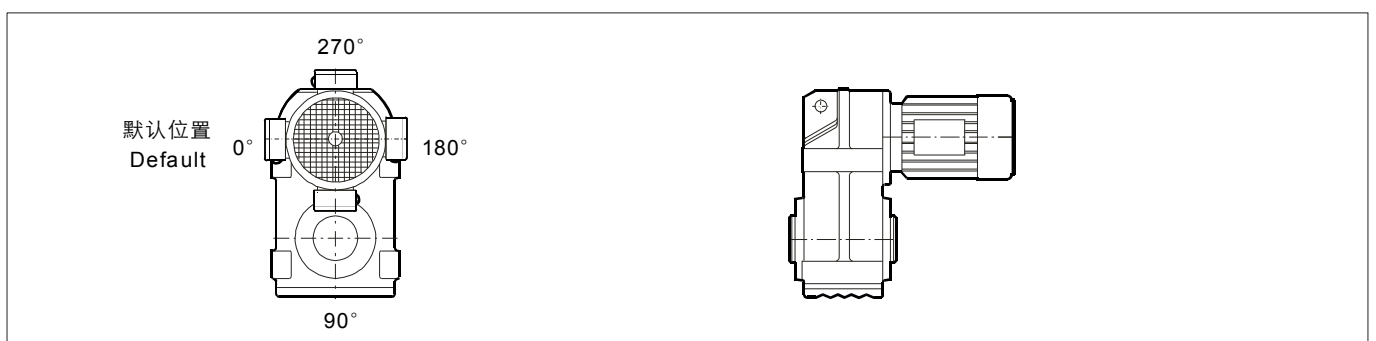



安装位置

Mounting Position

YFF, YFAF, YFHF 减速机安装位置

YFF, YFAF, YFHF Gear Unit Mounting Position

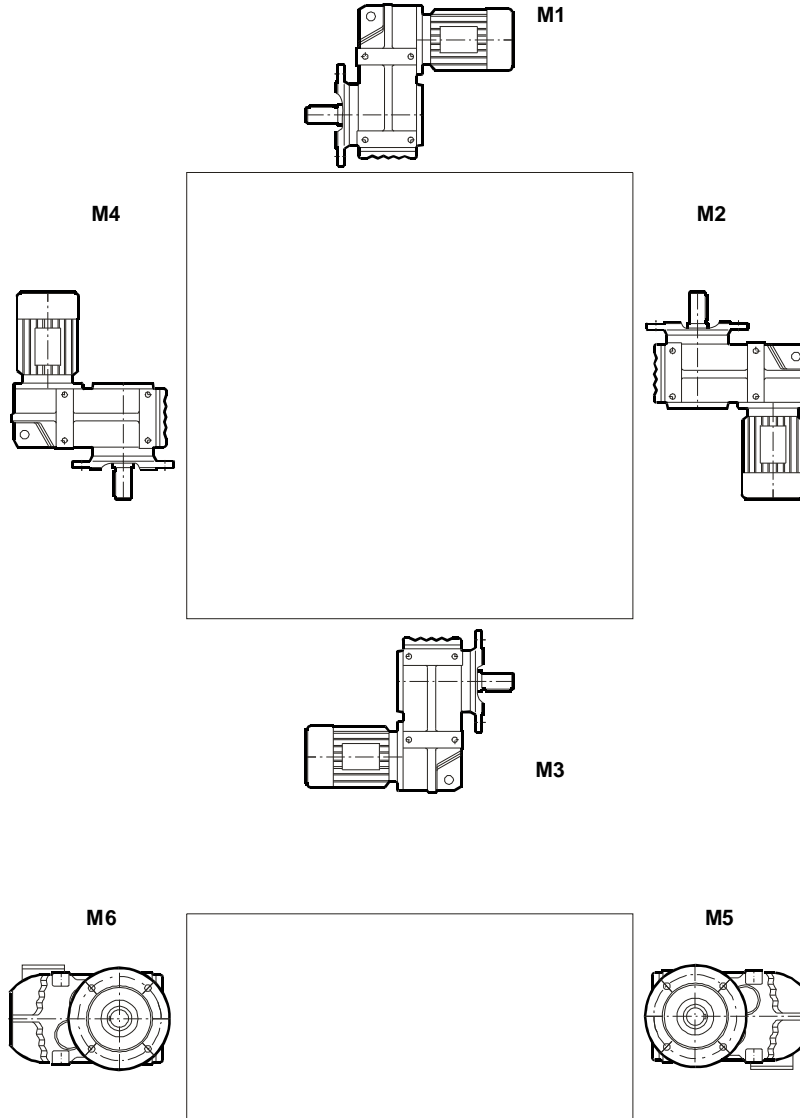

接线盒位置

Terminal Box Position

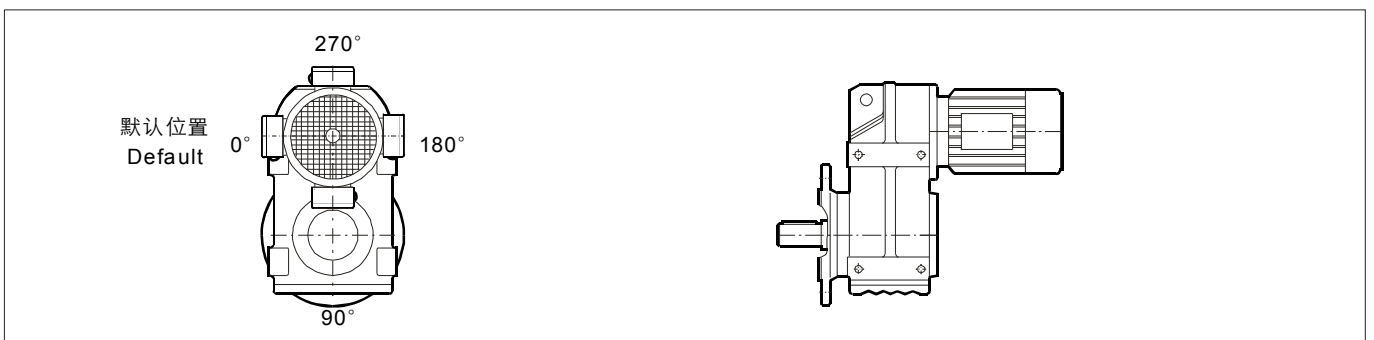



技术参数

Technical Data

符号意义

Key to Symbols

①  
↓

**$P_1 = 0.12 \text{ kW}$**

<b>N<sub>A</sub></b> rpm	<b>M<sub>2</sub></b> Nm	<b>i</b>	<b>Fr<sub>2MAX</sub></b> [N]	<b>f<sub>s</sub></b>	<b>Type</b>	<b>Gear unit</b>	<b>Motor size</b>	 Kg
0.06	13900	22323	86700	0.85				
0.07	11900	19048	90000	1.00	YFA	127YR77	63M1-4	425
0.08	10400	16656	90000	1.15	YFAF	127YR77	63M1-4	465
0.09	9180	14722	90000	1.30	YF	127YR77	63M1-4	460
0.11	8000	12912	90000	1.50	YFF	127YR77	63M1-4	510
0.12	7050	11656	90000	1.70				
0.14	6310	10191	90000	1.90				
↑ ②	↑ ③	↑ ④	↑ ⑤	↑ ⑥	↑ ⑦	↑ ⑧	↑ ⑨	↑ ⑩

- 1 电机功率
- 2 输出转速
- 3 输出转矩
- 4 减速比
- 5 输出轴中最大点载荷
- 6 使用系数
- 7 减速机类型
- 8 减速机规格
- 9 电机型号
- 10 大概重量

- 1 motor power
- 2 output speed
- 3 output torque
- 4 transmission ratio
- 5 maximum load on middle output shaft
- 6 service factor
- 7 gear unit type
- 8 gear unit size
- 9 motor frame
- 10 approximate weight



技术参数

Technical Data

P <sub>1</sub> = 0.12 kW								
N <sub>A</sub> rpm	M <sub>2</sub> Nm	i	Fr <sub>2</sub> MAX[N]	f <sub>s</sub>	Type	Gear unit	Motor size	 Kg
0.06	13900	22323	86700	0.85				
0.07	11900	19048	90000	1.00				
0.08	10400	16656	90000	1.15	YFA	127 YR77	63M1-4	425
0.09	9180	14722	90000	1.30	YFAF	127 YR77	63M1-4	465
0.11	8000	12912	90000	1.50	YF	127 YR77	63M1-4	460
0.12	7050	11656	90000	1.70	YFF	127 YR77	63M1-4	510
0.14	6310	10191	90000	1.90				
0.09	9210	14767	45500	0.85				
0.12	7080	11348	51400	1.10				
0.14	5750	10039	54600	1.35				
0.16	4680	8548	57000	1.65	YFA	107 YR77	63M1-4	275
0.18	4750	7674	56800	1.60	YFAF	107 YR77	63M1-4	295
0.20	4090	6767	58200	1.90	YF	107 YR77	63M1-4	290
0.23	3470	5954	59500	2.2	YFF	107 YR77	63M1-4	320
0.26	2990	5223	60400	2.6				
0.30	2850	4567	60700	2.7				
0.39	2130	3521	62000	3.6				
0.21	4150	6469	30400	1.05	YFA	97 YR57	63M1-4	185
0.25	3820	5615	31300	1.15	YFAF	97 YR57	63M1-4	205
0.28	3320	4961	32500	1.30	YF	97 YR57	63M1-4	190
0.32	2900	4333	33500	1.50	YFF	97 YR57	63M1-4	225
0.35	2690	3906	34000	1.60	YFA	97 YR57	63M1-4	185
0.41	2320	3352	34800	1.85	YFAF	97 YR57	63M1-4	205
0.47	1920	2907	35500	2.2	YF	97 YR57	63M1-4	190
0.54	1760	2553	35800	2.4	YFF	97 YR57	63M1-4	225
0.33	2770	4245	23800	1.10	YFA	87 YR57	63M1-4	120
0.37	2220	3721	25800	1.35	YFAF	87 YR57	63M1-4	130
					YF	87 YR57	63M1-4	125
					YFF	87 YR57	63M1-4	140
0.43	2250	3244	25700	1.35				
0.48	1990	2881	26500	1.50				
0.54	1780	2576	27100	1.70	YFA	87 YR57	63M1-4	115
0.63	1520	2199	27800	2.0	YFAF	87 YR57	63M1-4	130
0.72	1310	1930	28300	2.3	YF	87 YR57	63M1-4	125
0.81	1180	1709	28600	2.6	YFF	87 YR57	63M1-4	140
0.92	1030	1493	28900	2.9				
1.1	820	1300	29300	3.7				
1.2	745	1148	29500	4.0				
0.53	1820	2613	13000	0.80	YFA	77 YR37	63M1-4	65
0.60	1570	2284	15200	0.95	YFAF	77 YR37	63M1-4	72
0.68	1390	2029	16400	1.10	YF	77 YR37	63M1-4	69
					YFF	77 YR37	63M1-4	80



技术参数

Technical Data

P <sub>1</sub> = 0.12 kW								
N <sub>A</sub> rpm	M <sub>2</sub> Nm	i	Fr <sub>2</sub> MAX[N]	f <sub>s</sub>	Type	Gear unit	Motor size	 Kg
0.80	1180	1728	17500	1.25				
0.89	1090	1544	17900	1.40				
1.0	960	1354	18500	1.55	YFA	77 YR37	63M1-4	65
1.2	850	1200	18800	1.75	YFAF	77 YR37	63M1-4	72
1.3	745	1053	19100	2.0	YF	77 YR37	63M1-4	69
1.5	635	910	19400	2.4	YFF	77 YR37	63M1-4	80
1.7	530	810	19600	2.8				
1.9	465	710	19800	3.2				
0.97	960	1429	7070	0.85				
1.1	870	1271	9850	0.95				
1.2	725	1102	11100	1.15				
1.4	640	970	11700	1.30	YFA	67 YR37	63M1-4	43
1.6	560	858	12100	1.45	YFAF	67 YR37	63M1-4	49
1.8	495	755	12400	1.65	YF	67 YR37	63M1-4	46
2.1	420	641	12700	1.95	YFF	67 YR37	63M1-4	52
2.4	390	572	12800	2.1				
2.7	330	509	13000	2.5				
3.2	290	437	13000	2.9				
1.6	615	851	9100	1.00				
1.9	525	738	9750	1.15	YFA	57 YR37	63M1-4	39
2.1	455	646	10200	1.30	YFAF	57 YR37	63M1-4	45
2.5	390	558	10600	1.55	YF	57 YR37	63M1-4	39
2.7	345	506	10900	1.75	YFF	57 YR37	63M1-4	46
3.1	300	452	11100	2.0				
3.2	310	426	11100	1.95	YFA	57 YR37	63M1-4	38
3.6	275	382	11300	2.2	YFAF	57 YR37	63M1-4	44
4.2	235	330	11500	2.6	YF	57 YR37	63M1-4	39
4.6	210	298	11500	2.9	YFF	57 YR37	63M1-4	45
5.3	185	262	11500	3.2				
2.5	385	543	6100	1.05	YFA	47 YR17	63M1-4	24
2.9	335	475	6740	1.20	YFAF	47 YR17	63M1-4	27
3.3	290	419	7150	1.40	YF	47 YR17	63M1-4	25
					YFF	47 YR17	63M1-4	28
2.6	380	524	6190	1.05				
2.8	355	489	6530	1.15	YFA	47 YR17	63M1-4	23
3.2	305	427	7020	1.30	YFAF	47 YR17	63M1-4	26
3.6	270	381	7310	1.50	YF	47 YR17	63M1-4	24
4.1	235	334	7550	1.70	YFF	47 YR17	63M1-4	27
4.7	205	295	7740	1.95				
5.5	172	253	7910	2.3				
4.3	220	322	3990	0.90	YFA	37 YR17	63M1-4	19
5.0	192	278	4410	1.05	YFAF	37 YR17	63M1-4	20
5.7	162	242	4750	1.25	YF	37 YR17	63M1-4	19
6.2	156	221	4820	1.30	YFF	37 YR17	63M1-4	21



技术参数

Technical Data

P <sub>1</sub> = 0.12 kW								
N <sub>A</sub> rpm	M <sub>2</sub> Nm	i	Fr <sub>2</sub> MAX[N]	f <sub>s</sub>	Type	Gear unit	Motor size	 Kg
4.2	235	326	3710	0.85				
4.9	205	285	4250	1.00	YFA	37 YR17	63M1-4	19
5.5	177	250	4590	1.15	YFAF	37 YR17	63M1-4	20
6.3	156	219	4820	1.30	YF	37 YR17	63M1-4	19
7.4	132	186	5040	1.50	YFF	37 YR17	63M1-4	21
8.3	118	167	5140	1.70				
6.2	155	221	4500	0.85	YFA	27 YR17	63M1-4	13
8.0	119	172	4500	1.10	YFAF	27 YR17	63M1-4	14
9.1	104	153	4500	1.25	YF	27 YR17	63M1-4	13
11	87	130	4500	1.50	YFF	27 YR17	63M1-4	14
6.5	150	211	4500	0.85				
7.4	131	186	4500	1.00	YFA	27 YR17	63M1-4	13
9.7	102	142	4500	1.25	YFAF	27 YR17	63M1-4	13
11	88	124	4500	1.45	YF	27 YR17	63M1-4	13
13	77	109	4500	1.70	YFF	27 YR17	63M1-4	14
14	67	96	4500	1.95				
3.9	290	228.99	13000	2.8	YFA	67	63M2-6	32
4.6	250	195.39	13000	3.3	YFAF	67	63M2-6	38
5.3	220	170.85	13000	3.8	YF	67	63M2-6	35
5.5	205	162.31	13000	4.0	YFF	67	63M2-6	41
6.3	181	142.40	13000	4.5				
4.5	255	199.70	11400	2.4	YFA	57	63M2-6	28
4.9	235	183.60	11500	2.6	YFAF	57	63M2-6	34
5.7	200	157.09	11500	3.0	YF	57	63M2-6	28
6.6	173	136.16	11500	3.5	YFF	57	63M2-6	35
7.1	162	127.27	11500	3.7				
6.9	166	199.70	11500	3.6	YFA	57	63M1-4	28
7.5	153	183.60	11500	3.9	YFAF	57	63M1-4	34
8.8	130	157.09	11500	4.6	YF	57	63M1-4	28
10	113	136.16	11500	5.3	YFF	57	63M1-4	35
4.7	245	190.76	7510	1.65				
5.1	225	175.38	7640	1.80				
6.0	191	150.06	7820	2.1	YFA	47	63M2-6	21
6.9	166	130.07	7940	2.4	YFAF	47	63M2-6	24
7.4	155	121.57	7990	2.6	YF	47	63M2-6	22
8.6	134	105.09	8070	3.0	YFF	47	63M2-6	25
10	114	89.29	8130	3.5				
11	102	79.72	8160	3.9				
7.2	158	190.76	7970	2.5	YFA	47	63M1-4	21
7.9	146	175.38	8020	2.8	YFAF	47	63M1-4	24
9.2	125	150.06	8100	3.2	YF	47	63M1-4	22
11	108	130.07	8150	3.7	YFF	47	63M1-4	25



技术参数

Technical Data

<b>P<sub>1</sub> = 0.12 kW</b>								
--------------------------------	--	--	--	--	--	--	--	--

N <sub>A</sub> rpm	M <sub>2</sub> Nm	i	Fr <sub>2</sub> MAX[N]	f <sub>s</sub>	Type	Gear unit	Motor size	Kg
7.0	164	128.51	4740	1.20	YFA	37	63M2-6	16
7.6	150	117.88	4880	1.35	YFAF	37	63M2-6	18
9.0	128	100.36	5070	1.55	YF	37	63M2-6	17
10	110	86.53	5190	1.80	YFF	37	63M2-6	18
11	103	80.65	5240	1.95				
11	107	128.51	5220	1.85	YFA	37	63M1-4	16
12	98	117.88	5270	2.0	YFAF	37	63M1-4	18
14	83	100.36	5340	2.4	YF	37	63M1-4	17
16	72	86.53	5400	2.8	YFF	37	63M1-4	18
17	67	80.65	5410	3.0				

<b>P<sub>1</sub> = 0.18 kW</b>								
--------------------------------	--	--	--	--	--	--	--	--

0.10	13700	12912	87200	0.90				
0.11	12200	11656	90000	1.00	YFA	127 YR77	63M2-4	425
0.13	10800	10191	90000	1.10	YFAF	127 YR77	63M2-4	465
0.15	8950	8831	90000	1.35	YF	127 YR77	63M2-4	460
0.17	7740	7643	90000	1.55	YFF	127 YR77	63M2-4	510
0.20	7130	6715	90000	1.70				
0.15	8450	8548	47700	0.90				
0.17	8130	7674	48600	0.95	YFA	107 YR77	63M2-4	275
0.20	7070	6767	51400	1.10	YFAF	107 YR77	63M2-4	295
0.22	6090	5954	53800	1.25	YF	107 YR77	63M2-4	290
0.25	5290	5223	55700	1.45	YFF	107 YR77	63M2-4	320
0.29	4850	4567	56600	1.60				
0.37	3680	3521	59100	2.1				
0.43	3260	3037	59900	2.4	YFA	107 YR77	63M2-4	275
0.48	2960	2756	60500	2.6	YFAF	107 YR77	63M2-4	295
0.56	2540	2369	61200	3.0	YF	107 YR77	63M2-4	290
0.64	2220	2068	61800	3.5	YFF	107 YR77	63M2-4	315
0.30	4810	4333	22800	0.90				
0.34	4430	3906	29500	0.95				
0.39	3810	3352	31300	1.15				
0.45	3210	2907	32800	1.35	YFA	97 YR57	63M2-4	185
0.52	2900	2553	33600	1.50	YFAF	97 YR57	63M2-4	205
0.59	2550	2245	34300	1.70	YF	97 YR57	63M2-4	190
0.67	2210	1970	35000	1.95	YFF	97 YR57	63M2-4	225
0.77	1960	1722	35500	2.2				
0.86	1740	1527	35900	2.5				
0.99	1430	1327	36400	3.0				
1.1	1330	1171	36500	3.2				



技术参数

Technical Data

P <sub>1</sub> = 0.18 kW								
N <sub>A</sub> rpm	M <sub>2</sub> Nm	i	Fr <sub>2</sub> MAX[N]	f <sub>s</sub>	Type	Gear unit	Motor size	 Kg
0.51	2930	2576	22300	1.00				
0.60	2490	2199	24800	1.20				
0.68	2170	1930	25900	1.40				
0.77	1940	1709	26600	1.55	YFA	87 YR57	63M2-4	115
0.88	1700	1493	27300	1.75	YFAF	87 YR57	63M2-4	130
1.0	1400	1300	28100	2.1	YF	87 YR57	63M2-4	125
1.2	1260	1148	28400	2.4	YFF	87 YR57	63M2-4	140
1.3	1090	1010	28800	2.8				
1.5	970	887	29000	3.1				
1.7	840	780	29300	3.6				
<hr/>								
0.86	1780	1544	13500	0.85				
0.98	1560	1354	15300	0.95				
1.1	1380	1200	16500	1.10	YFA	77 YR37	63M2-4	65
1.2	1210	1053	17400	1.25	YFAF	77 YR37	63M2-4	72
1.4	1040	910	18200	1.45	YF	77 YR37	63M2-4	69
1.6	890	810	18700	1.70	YFF	77 YR37	63M2-4	80
1.9	780	710	19000	1.90				
2.1	695	615	19300	2.2				
<hr/>								
1.5	940	858	8660	0.85				
1.8	830	755	10200	1.00				
2.1	705	641	11200	1.15	YFA	67 YR37	63M2-4	43
2.3	645	572	11600	1.25	YFAF	67 YR37	63M2-4	49
2.6	560	509	12100	1.45	YF	67 YR37	63M2-4	46
3.0	480	437	12500	1.70	YFF	67 YR37	63M2-4	52
3.4	435	384	12700	1.90				
<hr/>								
2.6	580	500	12000	1.40				
2.9	530	454	12300	1.55				
3.4	455	392	12600	1.80	YFA	67 YR37	63M2-4	42
4.0	380	333	12900	2.2	YFAF	67 YR37	63M2-4	48
4.4	335	297	13000	2.4	YF	67 YR37	63M2-4	45
5.1	295	261	13000	2.8	YFF	67 YR37	63M2-4	51
5.5	265	238	13000	3.1				
6.6	220	200	13000	3.7				
<hr/>								
2.4	640	558	7570	0.95				
2.6	570	506	9420	1.05	YFA	57 YR37	63M2-4	39
2.9	500	452	9930	1.20	YFAF	57 YR37	63M2-4	45
3.4	425	386	10400	1.40	YF	57 YR37	63M2-4	39
3.9	370	338	10700	1.60	YFF	57 YR37	63M2-4	46



技术参数

Technical Data

P <sub>1</sub> = 0.18 kW									
NA rpm	M <sub>2</sub> Nm	i	Fr <sub>2</sub> MAX[N]	f <sub>s</sub>	Type	Gear unit	Motor size	Kg	
3.1	500	426	9910	1.20					
3.5	445	382	10300	1.35					
4.0	380	330	10700	1.55	YFA	57 YR37	63M2-4		38
4.4	345	298	10900	1.75	YFAF	57 YR37	63M2-4		44
5.0	305	262	11100	2.0	YF	57 YR37	63M2-4		39
5.8	255	226	11400	2.3	YFF	57 YR37	63M2-4		45
6.6	225	200	11500	2.7					
3.6	410	370	5210	0.95	YFA	47 YR17	63M2-4		24
4.1	375	324	6250	1.05	YFAF	47 YR17	63M2-4		27
4.6	325	288	6810	1.20	YF	47 YR17	63M2-4		25
5.3	280	249	7250	1.45	YFF	47 YR17	63M2-4		28
7.1	215	186	4060	0.95	YFA	37 YR17	63M2-4		19
7.9	194	167	4380	1.05	YFAF	37 YR17	63M2-4		20
9.1	171	145	4660	1.15	YF	37 YR17	63M2-4		19
10	151	129	4870	1.30	YFF	37 YR17	63M2-4		21
9.3	166	142	4500	0.80	YFA	27 YR17	63M2-4		13
11	144	124	4500	0.90	YFAF	27 YR17	63M2-4		13
12	126	109	4500	1.05	YF	27 YR17	63M2-4		13
14	110	96	4500	1.20	YFF	27 YR17	63M2-4		14
3.1	555	281.71	19600	2.7	YFA	77	71M1-6		57
3.3	520	262.93	19700	2.9	YFAF	77	71M1-6		63
3.9	445	225.79	19800	3.4	YF	77	71M1-6		60
					YFF	77	71M1-6		71
3.8	450	228.99	12600	1.80	YFA	67	71M1-6		33
4.5	385	195.39	12900	2.1	YFAF	67	71M1-6		39
5.1	340	170.85	13000	2.4	YF	67	71M1-6		36
					YFF	67	71M1-6		42
5.8	300	228.99	13000	2.8	YFA	67	63M2-4		32
6.8	255	195.39	13000	3.2	YFAF	67	63M2-4		38
7.7	225	170.85	13000	3.7	YF	67	63M2-4		35
					YFF	67	63M2-4		41
4.4	395	199.70	10600	1.50					
4.7	365	183.60	10800	1.65	YFA	57	71M1-6		29
5.5	310	157.09	11100	1.95	YFAF	57	71M1-6		34
6.4	270	136.16	11300	2.2	YF	57	71M1-6		29
6.8	250	127.27	11400	2.4	YFF	57	71M1-6		36
7.9	215	110.01	11500	2.8					
6.6	260	199.70	11300	2.3	YFA	57	63M2-4		28
7.2	240	183.60	11500	2.5	YFAF	57	63M2-4		34
8.4	205	157.09	11500	2.9	YF	57	63M2-4		28
9.7	177	136.16	11500	3.4	YFF	57	63M2-4		35
10	166	127.27	11500	3.6					



技术参数

Technical Data

P <sub>1</sub> = 0.18 kW								
N <sub>A</sub> rpm	M <sub>2</sub> Nm	i	Fr <sub>2</sub> MAX[N]	f <sub>s</sub>	Type	Gear unit	Motor size	 Kg
4.6	375	190.76	6240	1.05	YFA YFAF YF YFF	47	71M1-6	22
5.0	345	175.38	6600	1.15				
5.8	295	150.06	7090	1.35				
6.7	255	130.07	7410	1.55				
7.2	240	121.57	7530	1.65				
6.9	250	190.76	7470	1.60	YFA YFAF YF YFF	47	63M2-4	21
7.5	230	175.38	7610	1.75				
8.8	195	150.06	7800	2.1				
10	169	130.07	7920	2.4				
11	158	121.57	7970	2.5				
7.4	235	117.88	3750	0.85	YFA YFAF YF YFF	37	71M1-6	17
8.7	198	100.36	4320	1.00				
10	171	86.53	4660	1.15				
11	159	80.65	4790	1.25				
12	139	70.50	4970	1.45				
10	167	128.51	4700	1.20	YFA YFAF YF YFF	37	63M2-4	16
11	154	117.88	4850	1.30				
13	131	100.36	5050	1.55				
15	113	86.53	5180	1.75				
16	105	80.65	5230	1.90				
19	92	70.50	5300	2.2				
20	86	66.09	5330	2.3				
23	76	58.32	5380	2.6				
335	5.1	8.13	2190	24	YFA YFAF YF YFF	27	63MM1-2	9.6
394	4.4	6.91	2080	26				
441	3.9	6.17	2010	28				
516	3.3	5.27	1910	30				
551	3.1	4.93	1870	31				
655	2.6	4.16	1770	34				

P <sub>1</sub> = 0.25 kW								
0.15	13300	8831	87900	0.90	YFA YFAF YF YFF	127 YR77	71M1-4	425
0.17	11500	7643	90000	1.05				
0.19	10500	6715	90000	1.15				
0.22	9240	5925	90000	1.30				
0.25	7950	5153	90000	1.50				
0.29	6890	4533	90000	1.75				
0.22	9050	5954	46000	0.85	YFA YFAF YF YFF	107 YR77	71M1-4	275
0.25	7890	5223	49300	0.95				
0.28	7120	4567	51300	1.10				
0.37	5430	3521	55300	1.40				



技术参数

Technical Data

P <sub>1</sub> = 0.25 kW								
N <sub>A</sub> rpm	M <sub>2</sub> Nm	i	Fr <sub>2</sub> MAX[N]	f <sub>s</sub>	Type	Gear unit	Motor size	 Kg
0.43	4790	3037	56800	1.60				
0.47	4340	2756	57700	1.75	YFA	107 YR77	71M1-4	275
0.55	3730	2369	59000	2.1	YFAF	107 YR77	71M1-4	295
0.63	3260	2068	59900	2.4	YF	107 YR77	71M1-4	290
0.81	2490	1597	61300	3.1	YFF	107 YR77	71M1-4	320
0.93	2160	1401	61900	3.6				
<hr/>								
0.45	4680	2907	27500	0.90				
0.51	4180	2553	30300	1.05				
0.58	3680	2245	31600	1.15	YFA	97 YR57	71M1-4	185
0.66	3200	1970	32800	1.35	YFAF	97 YR57	71M1-4	205
0.75	2820	1722	33700	1.50	YF	97 YR57	71M1-4	190
0.85	2500	1527	34400	1.70	YFF	97 YR57	71M1-4	225
0.98	2100	1327	35200	2.1				
1.1	1920	1171	35500	2.2				
1.3	1680	1022	36000	2.6				
<hr/>								
0.67	3140	1930	13500	0.95				
0.76	2800	1709	23700	1.05				
0.87	2450	1493	25000	1.25	YFA	87 YR57	71M1-4	120
1.0	2050	1300	26300	1.45	YFAF	87 YR57	71M1-4	130
1.1	1830	1148	26900	1.65	YF	87 YR57	71M1-4	125
1.3	1600	1010	27600	1.90	YFF	87 YR57	71M1-4	140
1.5	1420	887	28000	2.1				
1.7	1230	780	28500	2.4				
1.9	1050	674	28900	2.9				
<hr/>								
1.2	1740	1053	13900	0.85				
1.4	1500	910	15700	1.00				
1.6	1300	810	16900	1.15	YFA	77 YR37	71M1-4	66
1.8	1140	710	17700	1.30	YFAF	77 YR37	71M1-4	72
2.1	1000	615	18300	1.50	YF	77 YR37	71M1-4	70
2.4	880	538	18700	1.70	YFF	77 YR37	71M1-4	80
2.7	780	480	19000	1.95				
3.1	660	413	19400	2.3				
<hr/>								
2.3	930	572	9150	0.90	YFA	67 YR37	71M1-4	44
2.6	810	509	10400	1.00	YFAF	67 YR37	71M1-4	50
3.0	700	437	11200	1.15	YF	67 YR37	71M1-4	46
					YFF	67 YR37	71M1-4	53
<hr/>								
2.6	830	500	10200	1.00				
2.9	760	454	10800	1.10	YFA	67 YR37	71M1-4	42
3.3	655	392	11600	1.25	YFAF	67 YR37	71M1-4	49
3.9	550	333	12200	1.50	YF	67 YR37	71M1-4	45
4.4	490	297	12500	1.70	YFF	67 YR37	71M1-4	51
5.0	430	261	12700	1.90				
5.5	385	238	12900	2.1				



技术参数

Technical Data

P <sub>1</sub> = 0.25 kW									
N <sub>A</sub> rpm	M <sub>2</sub> Nm	i	Fr <sub>2</sub> MAX[N]	f <sub>s</sub>	Type	Gear unit	Motor size	Kg	
3.4	620	386	8830	0.95	YFA	57 YR37	71M1-4	40	
3.9	540	338	9640	1.10	YFAF	57 YR37	71M1-4	45	
5.1	410	255	10500	1.45	YF	57 YR37	71M1-4	40	
					YFF	57 YR37	71M1-4	46	
3.4	640	382	7390	0.95					
3.9	550	330	9570	1.10	YFA	57 YR37	71M1-4	39	
4.4	495	298	9950	1.20	YFAF	57 YR37	71M1-4	45	
5.0	435	262	10300	1.35	YF	57 YR37	71M1-4	39	
5.8	370	226	10700	1.60	YFF	57 YR37	71M1-4	46	
6.5	325	200	11000	1.85					
7.7	275	170	11300	2.2					
5.2	405	249	5880	1.00	YFA	47 YR17	71M1-4	25	
6.0	360	218	6470	1.10	YFAF	47 YR17	71M1-4	27	
6.7	315	193	6920	1.25	YF	47 YR17	71M1-4	25	
7.5	285	175	7180	1.40	YFF	47 YR17	71M1-4	28	
5.1	415	253	4980	0.95					
6.0	365	217	6380	1.10	YFA	47 YR17	71M1-4	24	
6.9	320	190	6900	1.25	YFAF	47 YR17	71M1-4	26	
7.3	295	178	7090	1.35	YF	47 YR17	71M1-4	25	
8.7	250	149	7480	1.60	YFF	47 YR17	71M1-4	28	
9.9	215	131	7670	1.85					
8.9	245	145	3420	0.80					
10	215	129	4040	0.90	YFA	37 YR17	71M1-4	20	
11	198	118	4320	1.00	YFAF	37 YR17	71M1-4	21	
13	164	98	4740	1.20	YF	37 YR17	71M1-4	20	
15	144	87	4940	1.40	YFF	37 YR17	71M1-4	22	
3.1	765	281.71	19100	1.95	YFA	77	71M2-6	57	
3.4	715	262.93	19200	2.1	YFAF	77	71M2-6	64	
3.9	615	225.79	19500	2.5	YF	77	71M2-6	61	
4.4	540	198.31	19600	2.8	YFF	77	71M2-6	72	
4.7	510	188.40	19700	2.9					
3.8	620	228.99	11800	1.30	YFA	67	71M2-6	34	
4.5	530	195.39	12300	1.55	YFAF	67	71M2-6	41	
5.2	465	170.85	12600	1.75	YF	67	71M2-6	37	
5.4	440	162.31	12700	1.85	YFF	67	71M2-6	43	
6.2	385	142.40	12900	2.1					
5.7	420	228.99	12700	1.95	YFA	67	71M1-4	33	
6.7	360	195.39	13000	2.3	YFAF	67	71M1-4	39	
7.6	315	170.85	13000	2.6	YF	67	71M1-4	36	
8.0	300	162.31	13000	2.8	YFF	67	71M1-4	42	
9.1	260	142.40	13000	3.1					



技术参数

Technical Data

P <sub>1</sub> = 0.25 kW								
N <sub>A</sub> rpm	M <sub>2</sub> Nm	i	Fr <sub>2</sub> MAX[N]	f <sub>s</sub>	Type	Gear unit	Motor size	 Kg
4.4	540	199.70	9630	1.10				
4.8	500	183.60	9940	1.20	YFA	57	71M2-6	30
5.6	425	157.09	10400	1.40	YFAF	57	71M2-6	36
6.5	370	136.16	10800	1.60	YF	57	71M2-6	31
6.9	345	127.27	10900	1.75	YFF	57	71M2-6	37
8.0	300	110.01	11100	2.0				
6.5	365	199.70	10800	1.65				
7.1	335	183.60	10900	1.80	YFA	57	71M1-4	29
8.3	290	157.09	11200	2.1	YFAF	57	71M1-4	34
9.6	250	136.16	11400	2.4	YF	57	71M1-4	29
10	235	127.27	11500	2.6	YFF	57	71M1-4	36
12	200	110.01	11500	3.0				
5.9	405	150.06	5750	1.00	YFA	47	71M2-6	22
6.8	355	130.07	6530	1.15	YFAF	47	71M2-6	25
7.2	330	121.57	6770	1.20	YF	47	71M2-6	23
8.4	285	105.09	7190	1.40	YFF	47	71M2-6	26
6.8	350	190.76	6550	1.15				
7.4	320	175.38	6850	1.25	YFA	47	71M1-4	22
8.7	275	150.06	7270	1.45	YFAF	47	71M1-4	24
10	240	130.07	7540	1.65	YF	47	71M1-4	22
11	225	121.57	7640	1.80	YFF	47	71M1-4	26
12	193	105.09	7810	2.1				
15	164	89.29	7950	2.4				
10	235	128.51	3690	0.85				
11	215	117.88	4040	0.90				
13	184	100.36	4500	1.10				
15	159	86.53	4790	1.25				
16	148	80.65	4900	1.35				
18	130	70.50	5060	1.55				
20	121	66.09	5120	1.65	YFA	37	71M1-4	17
22	107	58.32	5210	1.85	YFAF	37	71M1-4	18
24	100	54.54	5260	2.0	YF	37	71M1-4	17
25	95	51.70	5280	2.1	YFF	37	71M1-4	19
28	86	47.02	5330	2.3				
30	81	43.83	5360	2.5				
34	70	38.31	5400	2.8				
36	66	35.91	5420	3.0				
41	58	31.69	5450	3.4				



技术参数

Technical Data

P <sub>1</sub> = 0.37 kW								
N <sub>A</sub> rpm	M <sub>2</sub> Nm	i	Fr <sub>2</sub> MAX[N]	f <sub>s</sub>	Type	Gear unit	Motor size	 Kg
0.21	15000	6715	84600	0.80				
0.23	13200	5925	88100	0.90				
0.27	11400	5153	90000	1.05	YFA	127 YR77	71M2-4	425
0.30	9930	4533	90000	1.20	YFAF	127 YR77	71M2-4	465
0.35	8690	3926	90000	1.40	YF	127 YR77	71M2-4	465
0.40	7570	3454	90000	1.60	YFF	127 YR77	71M2-4	510
0.46	6610	3031	90000	1.80				
0.45	6850	3037	52000	1.10	YFA	107 YR77	71M2-4	275
0.50	6220	2756	53500	1.25	YFAF	107 YR77	71M2-4	295
0.58	5350	2369	55500	1.45	YF	107 YR77	71M2-4	290
0.67	4670	2068	57000	1.65	YFF	107 YR77	71M2-4	320
0.86	3580	1597	59300	2.2				
0.70	4540	1970	29200	0.95				
0.80	4000	1722	30800	1.10	YFA	97 YR57	71M2-4	185
0.90	3550	1527	32000	1.20	YFAF	97 YR57	71M2-4	205
1.0	3000	1327	33300	1.45	YF	97 YR57	71M2-4	190
1.2	2720	1171	33900	1.60	YFF	97 YR57	71M2-4	225
1.4	2370	1022	34700	1.80				
1.5	2000	898	35400	2.1				
1.1	2940	1300	22000	1.00				
1.2	2620	1148	24400	1.15				
1.4	2280	1010	25600	1.30	YFA	87 YR57	71M2-4	120
1.6	2020	887	26400	1.50	YFAF	87 YR57	71M2-4	130
1.8	1760	780	27100	1.70	YF	87 YR57	71M2-4	125
2.0	1500	674	27800	2.0	YFF	87 YR57	71M2-4	140
2.3	1380	609	28100	2.2				
2.7	1160	515	28600	2.6				
3.1	1020	452	28900	2.9				
1.7	1850	810	11300	0.80				
1.9	1620	710	14900	0.95	YFA	77 YR37	71M2-4	67
2.2	1420	615	16200	1.05	YFAF	77 YR37	71M2-4	73
2.6	1240	538	17200	1.20	YF	77 YR37	71M2-4	71
2.9	1110	480	17900	1.35	YFF	77 YR37	71M2-4	81
3.4	940	413	18500	1.60				
3.8	840	367	18900	1.80				
4.3	750	323	19100	2.0				
3.6	890	384	9670	0.95	YFA	67 YR37	71M2-4	45
4.1	785	338	10600	1.05	YFAF	67 YR37	71M2-4	51
4.5	705	305	11200	1.15	YF	67 YR37	71M2-4	47
5.4	590	257	11900	1.40	YFF	67 YR37	71M2-4	53
6.0	525	231	12300	1.55				
5.4	585	255	9330	1.05	YFA	57 YR37	71M2-4	41
6.9	455	201	10200	1.30	YFAF	57 YR37	71M2-4	46
7.6	415	181	10500	1.45	YF	57 YR37	71M2-4	41
					YFF	57 YR37	71M2-4	47



技术参数

Technical Data

P <sub>1</sub> = 0.37 kW								
N <sub>A</sub> rpm	M <sub>2</sub> Nm	i	Fr <sub>2</sub> MAX[N]	f <sub>s</sub>	Type	Gear unit	Motor size	 Kg
5.3	620	262	9070	0.95				
6.1	525	226	9740	1.15	YFA	57 YR37	71M2-4	40
6.9	465	200	10200	1.30	YFAF	57 YR37	71M2-4	46
8.1	395	170	10600	1.50	YF	57 YR37	71M2-4	40
9.1	350	152	10900	1.70	YFF	57 YR37	71M2-4	47
10	310	134	11100	1.95				
7.9	405	175	5860	1.00	YFA	47 YR17	71M2-4	25
9.4	340	147	6660	1.15	YFAF	47 YR17	71M2-4	28
11	300	130	7050	1.35	YF	47 YR17	71M2-4	26
					YFF	47 YR17	71M2-4	29
2.5	1410	270.68	28100	2.1	YFA	87	90S-8	105
2.7	1330	255.37	28200	2.3	YFAF	87	90S-8	120
3.0	1190	228.93	28600	2.5	YF	87	90S-8	110
3.5	1020	197.20	28900	2.9	YFF	87	90S-8	125
3.3	1060	270.68	28800	2.8	YFA	87	80M1-6	98
3.5	1000	255.37	29000	3.0	YFAF	87	80M1-6	110
3.9	900	228.93	29200	3.3	YF	87	80M1-6	105
					YFF	87	80M1-6	120
4.0	890	225.79	18700	1.70	YFA	77	80M1-6	59
4.5	780	198.31	19100	1.95	YFAF	77	80M1-6	66
4.8	740	188.40	19200	2.0	YF	77	80M1-6	63
5.4	655	166.47	19400	2.3	YFF	77	80M1-6	74
6.3	560	142.27	19600	2.7				
4.9	720	281.71	19200	2.1	YFA	77	71M2-4	57
5.2	675	262.93	19300	2.2	YFAF	77	71M2-4	64
6.1	580	225.79	19500	2.6	YF	77	71M2-4	61
7.0	510	198.31	19700	3.0	YFF	77	71M2-4	72
4.6	765	195.39	10800	1.05	YFA	67	80M1-6	36
5.3	670	170.85	11500	1.20	YFAF	67	80M1-6	43
5.5	635	162.31	11700	1.30	YF	67	80M1-6	39
6.3	560	142.40	12100	1.45	YFF	67	80M1-6	45
7.5	475	120.79	12500	1.75				
6.0	585	228.99	12000	1.40	YFA	67	71M2-4	34
7.1	500	195.39	12400	1.65	YFAF	67	71M2-4	41
8.1	435	170.85	12700	1.85	YF	67	71M2-4	37
8.5	415	162.31	12800	1.95	YFF	67	71M2-4	43
9.7	365	142.40	12900	2.3				
11	310	120.79	13000	2.7				



技术参数

Technical Data

<b>P<sub>1</sub> = 0.37 kW</b>								
--------------------------------	--	--	--	--	--	--	--	--

N <sub>A</sub> rpm	M <sub>2</sub> Nm	i	Fr <sub>2</sub> MAX[N]	f <sub>s</sub>	Type	Gear unit	Motor size	Kg
5.7	615	157.09	9070	0.95	YFA	57	80M1-6	32
6.6	535	136.16	9680	1.10	YFAF	57	80M1-6	38
7.1	500	127.27	9930	1.20	YF	57	80M1-6	33
8.2	430	110.01	10400	1.40	YFF	57	80M1-6	39
6.9	510	199.70	9850	1.15				
7.5	470	183.60	10100	1.30				
8.8	400	157.09	10600	1.50	YFA	57	71M2-4	30
10	350	136.16	10900	1.70	YFAF	57	71M2-4	36
11	325	127.27	11000	1.85	YF	57	71M2-4	31
13	280	110.01	11200	2.1	YFF	57	71M2-4	37
15	240	93.47	11500	2.5				
17	215	83.46	11500	2.8				
9.2	385	150.06	6140	1.05				
11	335	130.07	6740	1.20	YFA	47	71M2-4	22
13	270	105.09	7320	1.50	YFAF	47	71M2-4	25
15	230	89.29	7600	1.75	YF	47	71M2-4	23
17	205	79.72	7750	1.95	YFF	47	71M2-4	26
20	174	68.09	7900	2.3				
21	167	65.36	7930	2.4				
16	220	86.53	3960	0.90				
17	205	80.65	4200	0.95				
20	181	70.50	4550	1.10				
21	169	66.09	4680	1.20				
24	149	58.32	4890	1.35				
25	140	54.54	4970	1.45	YFA	37	71M2-4	18
27	132	51.70	5030	1.50	YFAF	37	71M2-4	19
29	120	47.02	5120	1.65	YF	37	71M2-4	18
31	112	43.83	5180	1.80	YFF	37	71M2-4	20
36	98	38.31	5270	2.0				
38	92	35.91	5300	2.2				
44	81	31.69	5300	2.5				
49	72	28.09	5140	2.8				
58	61	23.88	4930	3.3				

<b>P<sub>1</sub> = 0.55 kW</b>								
--------------------------------	--	--	--	--	--	--	--	--

0.22	20500	6295	91800	0.90	YFA	157 YR97	80M1-4	770
0.25	17200	5404	102700	1.05	YFAF	157 YR97	80M1-4	820
0.49	8820	2780	118800	2.0	YF	157 YR97	80M1-4	790
					YFF	157 YR97	80M1-4	890
0.56	7800	2427	120000	2.3	YFA	157 YR97	80M1-4	760
0.81	5530	1674	120000	3.3	YFAF	157 YR97	80M1-4	820
1.0	4270	1308	120000	4.2	YF	157 YR97	80M1-4	780
1.2	3750	1169	120000	4.8	YFF	157 YR97	80M1-4	890



技术参数

Technical Data

P <sub>1</sub> = 0.55 kW								
NA rpm	M <sub>2</sub> Nm	i	Fr <sub>2</sub> MAX[N]	f <sub>s</sub>	Type	Gear unit	Motor size	 Kg
0.35	13400	3926	87700	0.90	YFA	127 YR77	80M1-4	430
0.39	11800	3454	90000	1.00	YFAF	127 YR77	80M1-4	465
0.45	10300	3031	90000	1.15	YF	127 YR77	80M1-4	465
					YFF	127 YR77	80M1-4	510
0.57	8250	2369	48300	0.95				
0.66	7200	2068	51100	1.05				
0.74	6190	1826	53600	1.25				
0.85	5540	1597	55100	1.40	YFA	107 YR77	80M1-4	275
0.97	4830	1401	56700	1.60	YFAF	107 YR77	80M1-4	300
1.1	4220	1243	58000	1.80	YF	107 YR77	80M1-4	295
1.2	3770	1087	58900	2.0	YFF	107 YR77	80M1-4	320
1.4	3220	950	60000	2.4				
1.6	2800	834	60800	2.7				
2.1	2180	640	61900	3.5				
1.0	4630	1327	28900	0.95				
1.2	4150	1171	30300	1.05				
1.3	3630	1022	31800	1.20				
1.5	3110	898	33100	1.40	YFA	97 YR57	80M1-4	185
1.7	2750	784	33900	1.55	YFAF	97 YR57	80M1-4	210
2.0	2380	690	34600	1.80	YF	97 YR57	80M1-4	195
2.2	2100	605	35200	2.1	YFF	97 YR57	80M1-4	225
2.6	1830	529	35700	2.4				
2.9	1610	467	36100	2.7				
3.4	1390	406	36500	3.1				
3.7	1240	363	36700	3.5				
1.5	3110	887	15200	0.95				
1.7	2720	780	24000	1.10	YFA	87 YR57	80M1-4	120
2.0	2330	674	25400	1.30	YFAF	87 YR57	80M1-4	135
2.2	2120	609	26100	1.40	YF	87 YR57	80M1-4	125
2.6	1790	515	27000	1.70	YFF	87 YR57	80M1-4	145
3.0	1580	452	27600	1.90				
3.9	1180	345	28600	2.5				
2.8	1690	480	14300	0.90	YFA	77 YR37	80M1-4	69
3.3	1450	413	16100	1.05	YFAF	77 YR37	80M1-4	75
3.7	1290	367	17000	1.15	YF	77 YR37	80M1-4	73
4.2	1150	323	17700	1.30	YFF	77 YR37	80M1-4	83
5.3	910	257	9470	0.90	YFA	67 YR37	80M1-4	47
5.9	810	231	10400	1.00	YFAF	67 YR37	80M1-4	53
6.6	720	205	11100	1.15	YF	67 YR37	80M1-4	49
7.8	615	175	11800	1.35	YFF	67 YR37	80M1-4	55



技术参数

Technical Data

P <sub>1</sub> = 0.55 kW								
N <sub>A</sub> rpm	M <sub>2</sub> Nm	i	Fr <sub>2</sub> MAX[N]	f <sub>s</sub>	Type	Gear unit	Motor size	 Kg
2.5	2140	276.77	35100	2.0	YFA	97	90L-8	170
2.7	1960	253.41	35500	2.2	YFAF	97	90L-8	190
3.0	1730	223.88	35900	2.5	YF	97	90L-8	175
					YFF	97	90L-8	210
2.5	2090	270.68	26200	1.45	YFA	87	90L-8	105
2.7	1970	255.37	26500	1.50	YFAF	87	90L-8	120
3.0	1770	228.93	27100	1.70	YF	87	90L-8	110
3.5	1520	197.20	27800	1.95	YFF	87	90L-8	125
3.3	1580	270.68	27600	1.90	YFA	87	80M2-6	100
3.5	1490	255.37	27800	2.0	YFAF	87	80M2-6	115
3.9	1340	228.93	28200	2.3	YF	87	80M2-6	105
4.6	1150	197.20	28700	2.6	YFF	87	80M2-6	120
5.0	1050	179.97	28900	2.9				
4.0	1320	225.79	16800	1.15				
4.5	1160	198.31	17600	1.30	YFA	77	80M2-6	61
4.8	1100	188.40	17900	1.35	YFAF	77	80M2-6	68
5.4	970	166.47	18400	1.55	YF	77	80M2-6	65
6.3	830	142.27	18900	1.80	YFF	77	80M2-6	76
6.9	760	130.42	19100	1.95				
6.0	870	225.79	18800	1.70				
6.9	765	198.31	19100	1.95				
7.2	730	188.40	19200	2.1	YFA	77	80M1-4	59
8.2	645	166.47	19400	2.3	YFAF	77	80M1-4	66
9.6	550	142.27	19600	2.7	YF	77	80M1-4	63
10	505	130.42	19700	3.0	YFF	77	80M1-4	74
12	440	114.45	19800	3.4				
13	420	108.46	19800	3.6				
14	365	94.93	19900	4.1				
7.0	755	195.39	10900	1.10				
8.0	660	170.85	11500	1.25				
8.4	625	162.31	11700	1.30	YFA	67	80M1-4	36
9.6	550	142.40	12200	1.50	YFAF	67	80M1-4	43
11	465	120.79	12600	1.75	YF	67	80M1-4	39
12	420	109.04	12700	1.95	YFF	67	80M1-4	45
14	370	95.94	12900	2.2				
15	350	90.59	13000	2.3				
17	310	79.76	13000	2.7				



技术参数

Technical Data

<b>P<sub>1</sub> = 0.55 kW</b>								
--------------------------------	--	--	--	--	--	--	--	--

N <sub>A</sub> rpm	M <sub>2</sub> Nm	i	Fr <sub>2</sub> MAX[N]	f <sub>s</sub>	Type	Gear unit	Motor size	Kg
8.7	605	157.09	9150	1.00				
10	525	136.16	9750	1.15				
11	490	127.27	9980	1.20				
12	425	110.01	10400	1.40	YFA	57	80M1-4	32
15	360	93.47	10800	1.65	YFAF	57	80M1-4	38
16	320	83.46	11000	1.85	YF	57	80M1-4	33
19	280	72.98	11200	2.1	YFF	57	80M1-4	39
20	265	68.22	11300	2.3				
23	230	58.97	11500	2.6				
<hr/>								
13	405	105.09	5840	1.00				
15	345	89.29	6620	1.15				
17	310	79.72	6990	1.30	YFA	47	80M1-4	24
20	265	68.09	7370	1.50	YFAF	47	80M1-4	27
21	250	65.36	7440	1.60	YF	47	80M1-4	25
24	220	56.49	7670	1.85	YFF	47	80M1-4	28
28	185	48.00	7850	2.2				
32	166	42.86	7940	2.4				
<hr/>								
23	225	58.32	3890	0.90				
25	210	54.54	4140	0.95				
26	200	51.70	4300	1.00				
29	182	47.02	4540	1.10	YFA	37	80M1-4	20
31	169	43.83	4680	1.20	YFAF	37	80M1-4	21
36	148	38.31	4900	1.35	YF	37	80M1-4	20
38	139	35.91	4980	1.45	YFF	37	80M1-4	22
43	122	31.69	4990	1.65				
48	109	28.09	4870	1.85				
57	92	23.88	4700	2.2				
<hr/>								
58	91	23.63	4690	2.2	YFA	37	80M1-4	19
66	79	20.57	4540	2.5	YFAF	37	80M1-4	21
71	74	19.27	4470	2.7	YF	37	80M1-4	20
80	66	17.03	4340	3.0	YFF	37	80M1-4	22
95	55	14.33	4150	3.6				

<b>P<sub>1</sub> = 0.75 kW</b>								
--------------------------------	--	--	--	--	--	--	--	--

0.50	12200	2780	113700	1	.45	YFA	157 YR97	80M2-4	770
						YFAF	157 YR97	80M2-4	830
						YF	157 YR97	80M2-4	790
						YFF	157 YR97	80M2-4	890
<hr/>									
0.57	10800	2427	116000	1	1.65	YFA	157 YR97	80M2-4	760
						YFAF	157 YR97	80M2-4	820
						YF	157 YR97	80M2-4	780
						YFF	157 YR97	80M2-4	890
<hr/>									
0.82	7630	1674	120000	1	2.4	YFAF	157 YR97	80M2-4	820
1.1	5910	1308	120000	1	3.1	YF	157 YR97	80M2-4	780
1.2	5210	1169	120000	1	3.5	YFF	157 YR97	80M2-4	890



技术参数

Technical Data

P <sub>1</sub> = 0.75 kW																	
N <sub>A</sub> rpm	M <sub>2</sub> Nm	i	Fr <sub>2</sub> MAX[N]	f <sub>s</sub>	Type	Gear unit	Motor size	Kg									
0.46	14000	3031	86500	0.85	YFA	127 YR77	80M2-4	430									
					YFAF	127 YR77	80M2-4	470									
					YF	127 YR77	80M2-4	465									
					YFF	127 YR77	80M2-4	510									
0.52	12600	2672	89200	0.95	YFA	127 YR77	80M2-4	430									
					0.59	11100	2357	90000	1.10	YFAF	127 YR77	80M2-4	465				
					0.68	9540	2038	90000	1.25	YF	127 YR77	80M2-4	465				
					0.77	8310	1784	90000	1.45	YFF	127 YR77	80M2-4	510				
					0.86	7450	1606	90000	1.60								
1.4	4900	1022	18500	0.90	YFA	97 YR57	80M2-4	190									
								1.5	4230	898	30100	1.00	YFAF	97 YR57	80M2-4	210	
								1.8	3730	784	31500	1.15	YF	97 YR57	80M2-4	195	
								2.0	3250	690	32700	1.30	YFF	97 YR57	80M2-4	230	
								2.3	2860	605	33600	1.50					
								2.6	2490	529	34400	1.75					
								3.0	2200	467	35000	1.95					
								3.4	1890	406	35600	2.3					
								3.8	1700	363	35900	2.5					
2.0	3170	674	11300	0.95	YFA	87 YR57	80M2-4	120									
					2.3	2880	609	23400	1.05	YFAF	87 YR57	80M2-4	135				
					2.7	2430	515	25000	1.25	YF	87 YR57	80M2-4	130				
					3.1	2140	452	26000	1.40	YFF	87 YR57	80M2-4	145				
					4.0	1610	345	27500	1.85								
3.8	1750	367	13800	0.85	YFA	77 YR37	80M2-4	70									
					4.3	1550	323	15400	0.95	YFAF	77 YR37	80M2-4	76				
					4.9	1340	280	16700	1.10	YF	77 YR37	80M2-4	74				
										YFF	77 YR37	80M2-4	84				
2.7	2640	254.40	61100	2.9	YFA	107	100L1-8	255									
					YFAF	107	100L1-8	275									
					YF	107	100L1-8	270									
					YFF	107	100L1-8	300									
2.5	2870	276.77	33600	1.50	YFA	97	100L1-8	180									
					2.7	2630	253.41	34100	1.65	YFAF	97	100L1-8	200				
					3.1	2320	223.88	34800	1.85	YF	97	100L1-8	185				
										YFF	97	100L1-8	220				
3.2	2200	276.77	35000	1.95	YFA	97	90S-6	170									
					3.6	2020	253.41	35400	2.1	YFAF	97	90S-6	190				
					4.0	1780	223.88	35800	2.4	YF	97	90S-6	175				
					YFF	97	90S-6	210									



技术参数

Technical Data

P <sub>1</sub> = 0.75 kW								
N <sub>A</sub> rpm	M <sub>2</sub> Nm	i	Fr <sub>2</sub> MAX[N]	f <sub>s</sub>	Type	Gear unit	Motor size	 Kg
3.3	2150	270.68	26000	1.40				
3.5	2030	255.37	26300	1.50	YFA	87	90S-6	105
3.9	1820	228.93	27000	1.65	YFAF	87	90S-6	120
4.6	1570	197.20	27600	1.90	YF	87	90S-6	110
5.0	1430	179.97	28000	2.1	YFF	87	90S-6	125
5.6	1270	159.61	28400	2.4				
5.1	1400	270.68	28100	2.1	YFA	87	80M2-4	100
5.4	1330	255.37	28200	2.3	YFAF	87	80M2-4	115
6.0	1190	228.93	28600	2.5	YF	87	80M2-4	105
					YFF	87	80M2-4	120
4.5	1580	198.31	15200	0.95	YFA	77	90S-6	66
4.8	1500	188.40	15700	1.00	YFAF	77	90S-6	73
5.4	1320	166.47	16800	1.15	YF	77	90S-6	70
6.3	1130	142.27	17800	1.30	YFF	77	90S-6	81
6.9	1040	130.42	18200	1.45				
6.1	1170	225.79	17600	1.30	YFA	77	80M2-4	61
7.0	1030	198.31	18200	1.45	YFAF	77	80M2-4	68
7.3	980	188.40	18400	1.55	YF	77	80M2-4	65
					YFF	77	80M2-4	76
8.3	860	166.47	18800	1.75	YFA	77	80M2-4	61
9.7	740	142.27	19200	2.0	YFAF	77	80M2-4	68
11	675	130.42	19300	2.2	YF	77	80M2-4	65
12	595	114.45	19500	2.5	YFF	77	80M2-4	76
13	565	108.46	19600	2.7				
8.1	890	170.85	9670	0.90	YFA	67	80M2-4	37
8.5	840	162.31	10100	0.95	YFAF	67	80M2-4	44
9.7	740	142.40	11000	1.10	YF	67	80M2-4	40
11	625	120.79	11700	1.30	YFF	67	80M2-4	46
13	565	109.04	12100	1.45				
14	500	95.94	12400	1.65	YFA	67	80M2-4	37
15	470	90.59	12500	1.75	YFAF	67	80M2-4	44
17	415	79.76	12800	2.0	YF	67	80M2-4	40
20	350	67.65	13000	2.3	YFF	67	80M2-4	46
23	315	61.07	13000	2.6				
11	660	127.27	5290	0.90	YFA	57	80M2-4	33
13	570	110.01	9420	1.05	YFAF	57	80M2-4	39
15	485	93.47	10000	1.25	YF	57	80M2-4	34
17	435	83.46	10400	1.40	YFF	57	80M2-4	40
19	380	72.98	10700	1.60				
20	355	68.22	10800	1.70				



技术参数

Technical Data

<b>P<sub>1</sub> = 0.75 kW</b>								
--------------------------------	--	--	--	--	--	--	--	--

N <sub>A</sub> rpm	M <sub>2</sub> Nm	i	Fr <sub>2</sub> MAX[N]	f <sub>s</sub>	Type	Gear unit	Motor size	Kg
23	305	58.97	11100	1.95	YFA	57	80M2-4	33
28	260	50.10	11300	2.3	YFAF	57	80M2-4	39
31	230	44.73	11400	2.6	YF	57	80M2-4	34
					YFF	57	80M2-4	40
17	415	79.72	5060	0.95	YFA	47	80M2-4	25
20	355	68.09	6520	1.15	YFAF	47	80M2-4	28
21	340	65.36	6680	1.20	YF	47	80M2-4	26
					YFF	47	80M2-4	29
24	295	56.49	7120	1.35				
29	250	48.00	7470	1.60	YFA	47	80M2-4	25
32	220	42.86	7640	1.80	YFAF	47	80M2-4	28
38	190	36.61	7820	2.1	YF	47	80M2-4	26
40	178	34.29	7850	2.3	YFF	47	80M2-4	29
48	150	28.88	7540	2.7				
29	245	47.02	3530	0.80				
31	230	43.83	3850	0.90	YFA	37	80M2-4	21
36	199	38.31	4310	1.00	YFAF	37	80M2-4	22
38	186	35.91	4480	1.05	YF	37	80M2-4	21
44	165	31.69	4620	1.20	YFF	37	80M2-4	23
49	146	28.09	4540	1.35				
58	123	23.63	4400	1.65				
67	107	20.57	4290	1.85	YFA	37	80M2-4	20
72	100	19.27	4240	2.0	YFAF	37	80M2-4	22
81	88	17.03	4130	2.3	YF	37	80M2-4	21
96	74	14.33	3970	2.7	YFF	37	80M2-4	23
107	67	12.87	3870	3.0				

<b>P<sub>1</sub> = 1.1 kW</b>								
-------------------------------	--	--	--	--	--	--	--	--

0.50	18200	2780	99600	1.00	YFA	157 YR97	90S-4	770
					YFAF	157 YR97	90S-4	830
					YF	157 YR97	90S-4	790
					YFF	157 YR97	90S-4	900
0.58	16100	2427	105500	1.10				
0.64	14400	2185	109500	1.25				
0.72	12800	1944	112700	1.40				
0.84	11300	1674	115300	1.60	YFA	157 YR97	90S-4	770
1.1	8750	1308	118900	2.1	YFAF	157 YR97	90S-4	830
1.2	7750	1169	120000	2.3	YF	157 YR97	90S-4	790
1.5	6200	953	120000	2.9	YFF	157 YR97	90S-4	900
1.7	5420	845	120000	3.3				
3.1	2870	446	120000	6.3				
4.6	1940	302	120000	9.3				



技术参数

Technical Data

P <sub>1</sub> = 1.1 kW								
N <sub>A</sub> rpm	M <sub>2</sub> Nm	i	Fr <sub>2</sub> MAX[N]	f <sub>s</sub>	Type	Gear unit	Motor size	 Kg
0.69	14000	2038	86600	0.85				
0.79	12200	1784	90000	1.00	YFA	127 YR77	90S-4	435
0.87	11000	1606	90000	1.10	YFAF	127 YR77	90S-4	470
1.0	9480	1390	90000	1.25	YF	127 YR77	90S-4	470
1.2	8280	1220	90000	1.45	YFF	127 YR77	90S-4	520
1.3	7360	1077	90000	1.65				
1.1	8480	1243	47600	0.90				
1.3	7490	1087	50300	1.00	YFA	107 YR77	90S-4	285
1.5	6480	950	52900	1.20	YFAF	107 YR77	90S-4	305
1.7	5660	834	54800	1.35	YF	107 YR77	90S-4	300
1.9	4970	736	56400	1.55	YFF	107 YR77	90S-4	330
2.2	4380	640	57600	1.75				
2.0	4750	690	25100	0.90				
2.3	4170	605	30300	1.05	YFA	97 YR57	90S-4	195
2.6	3640	529	31700	1.20	YFAF	97 YR57	90S-4	215
3.0	3210	467	32800	1.35	YF	97 YR57	90S-4	200
3.5	2770	406	33800	1.55	YFF	97 YR57	90S-4	235
3.9	2490	363	34400	1.75				
3.1	3130	452	14100	0.95	YFA	87 YR57	90S-4	125
4.1	2360	345	25300	1.25	YFAF	87 YR57	90S-4	140
4.7	2050	300	26300	1.45	YF	87 YR57	90S-4	135
5.6	1700	249	27300	1.75	YFF	87 YR57	90S-4	150
2.6	3990	254.40	58500	1.95	YFA	107	100L2-8	260
3.1	3380	215.37	59700	2.3	YFAF	107	100L2-8	280
3.4	3120	199.31	60200	2.5	YF	107	100L2-8	275
3.8	2800	178.64	60800	2.7	YFF	107	100L2-8	300
3.3	3160	276.77	32900	1.35	YFA	97	90L-6	170
3.6	2890	253.41	33600	1.50	YFAF	97	90L-6	190
4.1	2560	223.88	34300	1.70	YF	97	90L-6	175
4.8	2170	189.92	35100	2.0	YFF	97	90L-6	210
5.3	2000	174.87	35400	2.2				
5.1	2080	276.77	35200	2.1	YFA	97	90S-4	170
5.5	1900	253.41	35600	2.3	YFAF	97	90S-4	190
6.2	1680	223.88	36000	2.6	YF	97	90S-4	175
					YFF	97	90S-4	210
3.4	3090	270.68	16000	0.95				
3.6	2920	255.37	22700	1.05	YFA	87	90L-6	105
4.0	2610	228.93	24400	1.15	YFAF	87	90L-6	120
4.7	2250	197.20	25700	1.35	YF	87	90L-6	110
5.1	2050	179.97	26300	1.45	YFF	87	90L-6	125
5.8	1820	159.61	27000	1.65				



技术参数

Technical Data

P <sub>1</sub> = 1.1 kW								
N <sub>A</sub> rpm	M <sub>2</sub> Nm	i	Fr <sub>2</sub> MAX[N]	f <sub>s</sub>	Type	Gear unit	Motor size	 Kg
5.2	2030	270.68	26300	1.50				
5.5	1920	255.37	26700	1.55				
6.1	1720	228.93	27200	1.75	YFA	87	90S-4	105
7.1	1480	197.20	27900	2.0	YFAF	87	90S-4	120
7.8	1350	179.97	28200	2.2	YF	87	90S-4	110
8.8	1200	159.61	28500	2.5	YFF	87	90S-4	125
10	1010	134.16	29000	3.0				
11	930	123.29	29100	3.2				
7.1	1490	198.31	15800	1.00				
7.4	1410	188.40	16300	1.05				
8.4	1250	166.47	17200	1.20				
9.8	1070	142.27	18000	1.40	YFA	77	90S-4	66
11	980	130.42	18400	1.55	YFAF	77	90S-4	73
12	860	114.45	18800	1.75	YF	77	90S-4	70
13	810	108.46	18900	1.85	YFF	77	90S-4	81
15	710	94.93	19200	2.1				
16	640	85.52	19400	2.3				
19	565	75.02	19600	2.7				
12	910	120.79	9460	0.90				
13	820	109.04	10300	1.00				
15	720	95.94	11100	1.15				
15	680	90.59	11400	1.20				
18	600	79.76	11900	1.35	YFA	67	90S-4	42
21	510	67.65	12400	1.60	YFAF	67	90S-4	49
23	460	61.07	12600	1.80	YF	67	90S-4	45
26	405	53.73	12800	2.0	YFF	67	90S-4	51
28	380	50.74	12900	2.2				
32	325	43.20	13000	2.5				
36	295	39.26	13000	2.7				
41	255	34.01	13000	2.9				
17	625	83.46	8470	0.95				
19	550	72.98	9590	1.10				
21	510	68.22	9840	1.15	YFA	57	90S-4	38
24	440	58.97	10300	1.35	YFAF	57	90S-4	44
28	375	50.10	10700	1.60	YF	57	90S-4	39
31	335	44.73	10700	1.80	YFF	57	90S-4	45
37	285	38.21	10400	2.1				
39	270	35.79	10200	2.2				
46	225	30.15	9810	2.6				
25	425	56.49	3730	0.95	YFA	47	90S-4	31
29	360	48.00	6440	1.10	YFAF	47	90S-4	33
					YF	47	90S-4	32
					YFF	47	90S-4	35



技术参数

Technical Data

<b>P<sub>1</sub> = 1.1 kW</b>								
-------------------------------	--	--	--	--	--	--	--	--

N <sub>A</sub> rpm	M <sub>2</sub> Nm	i	Fr <sub>2</sub> MAX[N]	f <sub>s</sub>	Type	Gear unit	Motor size	Kg
33	320	42.86	6860	1.25	YFA	47	90S-4	31
38	275	36.61	7280	1.45	YFAF	47	90S-4	33
41	255	34.29	7260	1.55	YF	47	90S-4	32
48	215	28.88	7040	1.85	YFF	47	90S-4	35
<hr/>								
45	230	30.86	7130	1.75	YFA	47	90S-4	30
48	220	29.32	7060	1.80	YFAF	47	90S-4	33
54	193	25.72	6880	2.1	YF	47	90S-4	31
64	164	21.82	6640	2.4	YFF	47	90S-4	34
71	148	19.70	6490	2.7				
<hr/>								
44	240	31.69	3660	0.85	YFA	37	90S-4	26
50	210	28.09	3970	0.95	YFAF	37	90S-4	27
59	179	23.88	3930	1.10	YF	37	90S-4	26
					YFF	37	90S-4	28
<hr/>								
68	154	20.57	3870	1.30				
73	145	19.27	3840	1.40				
82	128	17.03	3780	1.55	YFA	37	90S-4	26
98	108	14.33	3680	1.85	YFAF	37	90S-4	27
109	97	12.87	3610	2.1	YF	37	90S-4	26
126	83	11.08	3500	2.3	YFF	37	90S-4	28
134	78	10.42	3460	2.4				
156	67	8.97	3350	2.6				

<b>P<sub>1</sub> = 1.5 kW</b>								
-------------------------------	--	--	--	--	--	--	--	--

0.58	22200	2427	83000	0.80				
0.65	19800	2185	94400	0.90				
0.73	17600	1944	101300	1.00				
0.84	15500	1674	107000	1.15	YFA	157 YR97	90L-4	770
1.1	12000	1308	114100	1.50	YFAF	157 YR97	90L-4	830
1.2	10700	1169	116300	1.70	YF	157 YR97	90L-4	790
1.5	8580	953	119100	2.1	YFF	157 YR97	90L-4	900
1.7	7540	845	120000	2.4				
3.2	3980	446	120000	4.5				
4.7	2700	302	120000	6.7				



技术参数

Technical Data

P <sub>1</sub> = 1.5kW								
N <sub>A</sub> rpm	M <sub>2</sub> Nm	i	Fr <sub>2</sub> MAX[N]	f <sub>s</sub>	Type	Gear unit	Motor size	 Kg
0.88	15000	1606	84600	0.80				
1.0	13000	1390	88600	0.95				
1.2	11300	1220	90000	1.05	YFA	127 YR77	90L-4	435
1.3	10100	1077	90000	1.20	YFAF	127 YR77	90L-4	475
1.5	8630	930	90000	1.40	YF	127 YR77	90L-4	470
1.7	7590	820	90000	1.60	YFF	127 YR77	90L-4	520
1.9	6710	727	90000	1.80				
2.2	6050	648	90000	2.0				
<hr/>								
1.5	8850	950	46600	0.85				
1.7	7740	834	49700	1.00				
1.9	6810	736	52100	1.15	YFA	107 YR77	90L-4	285
2.2	5980	640	54100	1.30	YFAF	107 YR77	90L-4	305
2.5	5170	560	55900	1.50	YF	107 YR77	90L-4	300
2.9	4520	489	57400	1.70	YFF	107 YR77	90L-4	330
3.2	4070	436	58300	1.90				
3.8	3450	370	59500	2.2				
<hr/>								
2.7	4960	529	15500	0.85	YFA	97 YR57	90L-4	195
3.0	4380	467	29700	1.00	YFAF	97 YR57	90L-4	215
3.5	3790	406	31300	1.15	YF	97 YR57	90L-4	200
3.9	3400	363	32400	1.25	YFF	97 YR57	90L-4	235
<hr/>								
4.7	2800	300	23700	1.05	YFA	87 YR57	90L-4	130
5.7	2320	249	25400	1.30	YFAF	87 YR57	90L-4	140
					YF	87 YR57	90L-4	135
					YFF	87 YR57	90L-4	150
<hr/>								
2.8	5210	254.40	55900	1.50	YFA	107	112M-8	265
3.2	4410	215.37	57600	1.75	YFAF	107	112M-8	285
3.5	4080	199.31	58300	1.90	YF	107	112M-8	280
3.9	3660	178.64	59100	2.1	YFF	107	112M-8	305
<hr/>								
3.6	3960	254.40	58500	1.95	YFA	107	100L-6	255
4.3	3350	215.37	59700	2.3	YFAF	107	100L-6	275
4.6	3100	199.31	60200	2.5	YF	107	100L-6	270
5.2	2780	178.64	60800	2.8	YFF	107	100L-6	300



技术参数

Technical Data

P <sub>1</sub> = 1.5kW								
NA rpm	M <sub>2</sub> Nm	i	Fr <sub>2</sub> MAX[N]	f <sub>s</sub>	Type	Gear unit	Motor size	 Kg
3.3	4310	276.77	29900	1.00	YFA YFAF YF YFF	97	100L-6	180
3.6	3950	253.41	30900	1.10				
4.1	3490	223.88	32100	1.25				
4.8	2960	189.92	33400	1.45				
5.3	2720	174.87	33900	1.60				
5.1	2810	276.77	33700	1.55	YFA YFAF YF YFF	97	90L-4	170
5.6	2570	253.41	34300	1.65				
6.3	2270	223.88	34900	1.90				
7.4	1930	189.92	35500	2.2				
8.1	1780	174.87	35800	2.4				
5.2	2750	270.68	23900	1.10	YFA YFAF YF YFF	87	90L-4	105
5.5	2590	255.37	24500	1.15				
6.2	2330	228.93	25400	1.30				
7.2	2000	197.20	26400	1.50				
7.8	1830	179.97	26900	1.65	YFA YFAF YF YFF	87	90L-4	105
8.8	1620	159.61	27500	1.85				
11	1360	134.16	28200	2.2				
13	1110	109.49	28700	2.7				
14	990	97.89	29000	3.0				
8.5	1690	166.47	14300	0.90	YFA YFAF YF YFF	77	90L-4	67
9.9	1450	142.27	16100	1.05				
11	1320	130.42	16800	1.15				
12	1160	114.45	17600	1.30				
13	1100	108.46	17900	1.35	YFA YFAF YF YFF	77	90L-4	67
15	960	94.93	18400	1.55				
16	870	85.52	18800	1.75				
19	760	75.02	19100	1.95				
19	735	72.50	19200	2.0				
21	675	66.46	19300	2.2				
24	595	58.32	19500	2.5				
26	560	55.27	19600	2.7				
29	490	48.37	19700	3.1				
32	445	43.58	19800	3.4				
37	390	38.23	19900	3.9				
39	370	36.58	19900	3.0	YFA YFAF YF YFF	77	90L-4	66
45	320	31.51	20000	4.3				
16	920	90.59	9300	0.90	YFA YFAF YF YFF	67	90L-4	44
18	810	79.76	10400	1.00				
21	685	67.65	11400	1.20				
23	620	61.07	11800	1.30				



技术参数

Technical Data

<b>P<sub>1</sub> = 1.5kW</b>								
------------------------------	--	--	--	--	--	--	--	--

N <sub>A</sub> rpm	M <sub>2</sub> Nm	i	Fr <sub>2</sub> MAX[N]	f <sub>s</sub>	Type	Gear unit	Motor size	Kg
26	545	53.73	12200	1.50	YFA	67	90L-4	44
28	515	50.74	12300	1.60	YFAF	67	90L-4	51
33	440	43.20	12700	1.85	YF	67	90L-4	47
36	400	39.26	12800	1.95	YFF	67	90L-4	53
39	370	36.30	12900	2.2	YFA	67	90L-4	43
44	325	32.08	13000	2.5	YFAF	67	90L-4	50
51	280	27.41	13000	2.9	YF	67	90L-4	46
56	255	25.13	13000	3.2	YFF	67	90L-4	52
24	600	58.97	9210	1.00				
28	510	50.10	9860	1.20	YFA	57	90L-4	40
32	455	44.73	9990	1.30	YFAF	57	90L-4	46
37	390	38.21	9740	1.55	YF	57	90L-4	41
39	365	35.79	9620	1.65	YFF	57	90L-4	47
47	305	30.15	9310	1.95				
33	435	42.86	575	0.90	YFA	47	90L-4	32
39	370	36.61	6300	1.10	YFAF	47	90L-4	35
41	350	34.29	6580	1.15	YF	47	90L-4	33
49	295	28.88	6500	1.35	YFF	47	90L-4	36
46	315	30.86	6550	1.30				
48	300	29.32	6510	1.35				
55	260	25.72	6390	1.55	YFA	47	90L-4	31
65	220	21.82	6230	1.80	YFAF	47	90L-4	34
72	200	19.70	6110	2.0	YF	47	90L-4	32
81	176	17.33	5970	2.3	YFF	47	90L-4	35
86	166	16.36	5900	2.4				
101	142	13.93	5700	2.8				
69	210	20.57	3410	0.95				
73	196	19.27	3410	1.00				
83	173	17.03	3400	1.15	YFA	37	90L-4	27
98	146	14.33	3350	1.35	YFAF	37	90L-4	29
110	131	12.87	3310	1.55	YF	37	90L-4	28
127	113	11.08	3250	1.70	YFF	37	90L-4	29
135	106	10.42	3220	1.75				
157	91	8.97	3140	1.90				
176	81	8.01	3080	2.1				

<b>P<sub>1</sub> = 2.2kW</b>								
------------------------------	--	--	--	--	--	--	--	--

0.98	18700	1441	98000	0.95	YFA	157 YR97	100L1-4	780
					YFAF	157 YR97	100L1-4	840
					YF	157 YR97	100L1-4	800
					YFF	157 YR97	100L1-4	910



技术参数

Technical Data

P <sub>1</sub> = 2.2kW								
N <sub>A</sub> rpm	M <sub>2</sub> Nm	i	Fr <sub>2</sub> MAX[N]	f <sub>s</sub>	Type	Gear unit	Motor size	 Kg
1.1	17900	1308	100700	1.00				
1.2	15900	1169	106000	1.15				
1.5	12800	953	112600	1.40				
1.7	11300	845	115300	1.60				
1.9	10200	764	117000	1.75	YFA	157 YR97	100L1-4	780
2.1	9040	680	118500	2.0	YFAF	157 YR97	100L1-4	840
2.5	7580	576	120000	2.4	YF	157 YR97	100L1-4	800
3.2	5970	446	120000	3.0	YFF	157 YR97	100L1-4	910
4.7	4040	302	120000	4.5				
5.2	3630	273	120000	5.0				
6.1	3050	232	120000	5.9				
7.2	2590	197	120000	7.0				
1.3	14900	1077	84800	0.80				
1.5	12800	930	88900	0.95				
1.7	11300	820	90000	1.05	YFA	127 YR77	100L1-4	445
1.9	9960	727	90000	1.20	YFAF	127 YR77	100L1-4	480
2.2	8940	648	90000	1.35	YF	127 YR77	100L1-4	480
2.6	7580	549	90000	1.60	YFF	127 YR77	100L1-4	520
2.9	6820	495	90000	1.75				
3.3	5900	428	90000	2.0				
2.2	8830	640	46600	0.85				
2.5	7670	560	49800	1.00	YFA	107 YR77	100L1-4	290
2.9	6700	489	52300	1.15	YFAF	107 YR77	100L1-4	315
3.2	6010	436	54000	1.30	YF	107 YR77	100L1-4	310
3.8	5100	370	56100	1.50	YFF	107 YR77	100L1-4	335
4.2	4590	333	57200	1.65				
4.9	3950	285	30900	1.10	YFA	97 YR57	100L1-4	200
5.8	3390	245	32400	1.25	YFAF	97 YR57	100L1-4	225
					YF	97 YR57	100L1-4	210
					YFF	97 YR57	100L1-4	240
2.8	7640	254.40	49900	1.00	YFA	107	132S-8	270
3.2	6460	215.37	52900	1.20	YFAF	107	132S-8	290
3.5	5980	199.31	54100	1.30	YF	107	132S-8	285
3.9	5360	178.64	55500	1.45	YFF	107	132S-8	315
3.7	5690	254.40	54800	1.35	YFA	107	112M-6	265
4.4	4810	215.37	56700	1.60	YFAF	107	112M-6	285
4.7	4450	199.31	57500	1.70	YF	107	112M-6	280
5.3	3990	178.64	58400	1.90	YFF	107	112M-6	305



技术参数

Technical Data

P <sub>1</sub> = 2.2kW								
NA rpm	M <sub>2</sub> Nm	i	Fr <sub>2</sub> MAX[N]	f <sub>s</sub>	Type	Gear unit	Motor size	 Kg
5.5	3790	254.40	58900	2.0	YFA	107	100L1-4	255
6.5	3210	215.37	60000	2.4	YFAF	107	100L1-4	275
7.1	2970	199.31	60400	2.6	YF	107	100L1-4	270
7.9	2660	178.64	61000	2.9	YFF	107	100L1-4	300
4.2	5000	223.88	12400	0.85	YFA	97	112M-6	190
5.0	4240	189.92	30100	1.00	YFAF	97	112M-6	210
5.4	3910	174.87	31000	1.10	YF	97	112M-6	195
6.0	3490	156.30	32100	1.25	YFF	97	112M-6	230
5.1	4120	276.77	30400	1.05				
5.6	3780	253.41	31400	1.15				
6.3	3340	223.88	32500	1.30	YFA	97	100L1-4	180
7.4	2830	189.92	33700	1.50	YFAF	97	100L1-4	200
8.1	2610	174.87	34200	1.65	YF	97	100L1-4	185
9.0	2330	156.30	34800	1.85	YFF	97	100L1-4	220
10	2100	140.71	35200	2.1				
11	1900	127.42	35600	2.3				
7.2	2940	197.20	22000	1.00	YFA	87	100L1-4	115
7.8	2680	179.97	24200	1.10	YFAF	87	100L1-4	125
8.8	2380	159.61	25200	1.25	YF	87	100L1-4	120
11	2000	134.16	26400	1.50	YFF	87	100L1-4	135
11	1840	123.29	26900	1.65				
13	1630	109.49	27500	1.85				
14	1460	97.89	27900	2.1	YFA	87	100L1-4	115
16	1310	88.01	28300	2.3	YFAF	87	100L1-4	125
18	1140	76.39	27800	2.6	YF	87	100L1-4	120
21	1020	68.40	27100	2.9	YFF	87	100L1-4	135
25	850	56.75	25900	3.6				
28	750	50.36	25200	3.9				
31	675	45.28	24500	4.2				
12	1710	114.45	14200	0.90	YFA	77	100L1-4	74
13	1620	108.46	14900	0.95	YFAF	77	100L1-4	81
15	1410	94.93	16300	1.05	YF	77	100L1-4	78
16	1270	85.52	17100	1.20	YFF	77	100L1-4	89
19	1120	75.02	17800	1.35				
21	990	66.46	18300	1.50	YFA	77	100L1-4	74
24	870	58.32	18800	1.75	YFAF	77	100L1-4	81
26	820	55.27	18900	1.80	YF	77	100L1-4	78
29	720	48.37	19200	2.1	YFF	77	100L1-4	89
32	650	43.58	19400	2.3				



技术参数

Technical Data

P <sub>1</sub> = 2.2kW								
N <sub>A</sub> rpm	M <sub>2</sub> Nm	i	Fr <sub>2</sub> MAX[N]	f <sub>s</sub>	Type	Gear unit	Motor size	 Kg
39	545	36.58	19600	2.0	YFA	77	100L1-4	73
45	470	31.51	19700	2.9	YFAF	77	100L1-4	79
49	430	28.75	19800	3.3	YF	77	100L1-4	77
55	380	25.50	19900	4.0	YFF	77	100L1-4	87
23	910	61.07	9420	0.90				
26	800	53.73	10500	1.00				
28	755	50.74	10800	1.10				
33	645	43.20	11600	1.25				
36	585	39.26	12000	1.35	YFA	67	100L1-4	51
41	505	34.01	12400	1.45	YFAF	67	100L1-4	58
44	480	32.08	12500	1.70	YF	67	100L1-4	54
51	410	27.41	12800	2.0	YFF	67	100L1-4	60
56	375	25.13	12900	2.2				
64	330	22.05	13000	2.5				
67	310	20.90	13000	2.6				
77	275	18.29	13000	3.0				
32	665	44.73	4480	0.90				
37	570	38.21	8660	1.05				
39	535	35.79	8620	1.15	YFA	57	100L1-4	47
47	450	30.15	8460	1.30	YFAF	57	100L1-4	53
56	370	24.96	8240	1.55	YF	57	100L1-4	48
67	315	21.17	8020	1.90	YFF	57	100L1-4	54
74	285	19.11	7870	2.1				
84	250	16.81	7670	2.4				
89	235	15.88	7580	2.5				
55	385	25.72	5560	1.05				
65	325	21.82	5520	1.25				
72	295	19.70	5480	1.35	YFA	47	100L1-4	38
81	260	17.33	5410	1.55	YFAF	47	100L1-4	40
86	245	16.36	5370	1.65	YF	47	100L1-4	38
101	210	13.93	5250	1.95	YFF	47	100L1-4	42
111	189	12.66	5170	2.1				
129	163	10.97	5040	2.5				
157	133	8.96	4740	2.5				
98	215	14.33	2790	0.95				
110	192	12.87	2810	1.05				
127	165	11.08	2820	1.15	YFA	37	100L1-4	33
135	155	10.42	2810	1.20	YFAF	37	100L1-4	35
157	134	8.97	2790	1.30	YF	37	100L1-4	34
176	119	8.01	2770	1.40	YFF	37	100L1-4	36
209	100	6.74	2630	1.40				
233	90	6.05	2590	1.50				
271	78	5.21	2540	1.60				



技术参数

Technical Data

<b>P<sub>1</sub> = 2.2kW</b>								
------------------------------	--	--	--	--	--	--	--	--

N <sub>A</sub> rpm	M <sub>2</sub> Nm	i	Fr <sub>2</sub> MAX[N]	f <sub>s</sub>	Type	Gear unit	Motor size	Kg
288	73	4.90	2520	1.65	YFA	37	100L1-4	33
334	63	4.22	2460	1.75	YFAF	37	100L1-4	35
374	56	3.77	2400	1.85	YF	37	100L1-4	34
					YFF	37	100L1-4	36

<b>P<sub>1</sub> = 3.0kW</b>								
------------------------------	--	--	--	--	--	--	--	--

1.2	22000	1169	86000	0.80				
1.5	17800	953	100800	1.00				
1.7	15700	845	106400	1.15				
1.8	14200	764	110000	1.25	YFA	157 YR97	100L2-4	780
2.1	12600	680	113000	1.45	YFAF	157 YR97	100L2-4	840
2.4	10600	576	116400	1.70	YF	157 YR97	100L2-4	800
3.1	8310	446	119400	2.2	YFF	157 YR97	100L2-4	910
4.6	5630	302	120000	3.2				
5.1	5070	273	120000	3.6				
6.0	4260	232	120000	4.2				
7.1	3620	197	120000	5.0				
1.9	13800	727	87000	0.85	YFA	127 YR77	100L2-4	445
2.2	12300	648	89800	0.95	YFAF	127 YR77	100L2-4	485
2.6	10500	549	90000	1.15	YF	127 YR77	100L2-4	485
2.8	9410	495	90000	1.30	YFF	127 YR77	100L2-4	530
3.2	8300	436	48100	0.95	YFA	107 YR77	100L2-4	295
3.8	7040	370	51500	1.10	YFAF	107 YR77	100L2-4	315
4.2	6340	333	53200	1.20	YF	107 YR77	100L2-4	310
4.8	5540	291	55100	1.40	YFF	107 YR77	100L2-4	340
3.7	7750	254.40	49600	1.00	YFA	107	132S-6	270
4.4	6560	215.37	52700	1.15	YFAF	107	132S-6	290
4.7	6070	199.31	53900	1.25	YF	107	132S-6	285
5.3	5440	178.64	55300	1.40	YFF	107	132S-6	315
5.5	5210	254.40	55900	1.50	YFA	107	100L2-4	260
6.5	4410	215.37	57600	1.75	YFAF	107	100L2-4	280
7.0	4080	199.31	58300	1.90	YF	107	100L2-4	275
7.8	3660	178.64	59100	2.1	YFF	107	100L2-4	300
8.7	3300	161.28	59800	2.3				



技术参数

Technical Data

P <sub>1</sub> = 3.0kW								
N <sub>A</sub> rpm	M <sub>2</sub> Nm	i	Fr <sub>2</sub> MAX[N]	f <sub>s</sub>	Type	Gear unit	Motor size	 Kg
6.2	4580	223.88	29000	0.95	YFA	97	100L2-4	180
7.4	3890	189.92	31100	1.10	YFAF	97	100L2-4	205
8.0	3580	174.87	31900	1.20	YF	97	100L2-4	190
					YFF	97	100L2-4	220
9.0	3200	156.30	32800	1.35				
10	2880	140.71	33600	1.50	YFA	97	100L2-4	180
11	2610	127.42	34200	1.65	YFAF	97	100L2-4	205
12	2310	112.99	34800	1.85	YF	97	100L2-4	190
14	2090	102.16	35200	2.1	YFF	97	100L2-4	220
16	1840	89.85	35700	2.3				
10	2750	134.16	23900	1.10	YFA	87	100L2-4	120
11	2520	123.29	24700	1.20	YFAF	87	100L2-4	130
13	2240	109.49	25700	1.35	YF	87	100L2-4	125
					YFF	87	100L2-4	140
14	2000	97.89	26400	1.50				
16	1800	88.01	26900	1.65	YFA	87	100L2-4	120
18	1560	76.39	26300	1.90	YFAF	87	100L2-4	130
20	1400	68.40	25700	2.1	YF	87	100L2-4	125
25	1160	56.75	24800	2.6	YFF	87	100L2-4	140
28	1030	50.36	24100	2.9				
16	1750	85.52	13800	0.85	YFA	77	100L2-4	78
19	1540	75.02	15500	1.00	YFAF	77	100L2-4	85
21	1360	66.46	16600	1.10	YF	77	100L2-4	82
					YFF	77	100L2-4	93
24	1190	58.32	17500	1.25	YFA	77	100L2-4	78
25	1130	55.27	17800	1.35	YFAF	77	100L2-4	85
29	990	48.37	18300	1.50	YF	77	100L2-4	82
32	890	43.58	18700	1.70	YFF	77	100L2-4	93
37	780	38.23	19000	1.90				
38	750	36.58	19100	1.50	YFA	77	100L2-4	77
44	645	31.51	19400	2.1	YFAF	77	100L2-4	83
49	590	28.75	19500	2.4	YF	77	100L2-4	81
55	520	25.50	19700	2.9	YFF	77	100L2-4	91
65	440	21.43	19800	3.4				



技术参数

Technical Data

P <sub>1</sub> = 3.0kW								
N <sub>A</sub> rpm	M <sub>2</sub> Nm	i	Fr <sub>2</sub> MAX[N]	f <sub>s</sub>	Type	Gear unit	Motor size	 Kg
32	880	43.20	9690	0.95	YFA	67	100L2-4	55
36	800	39.26	10500	0.95	YFAF	67	100L2-4	62
41	695	34.01	11300	1.05	YF	67	100L2-4	58
					YFF	67	100L2-4	64
44	655	32.08	11600	1.25				
51	560	27.41	12100	1.45				
56	515	25.13	12300	1.60	YFA	67	100L2-4	54
63	450	22.05	12600	1.80	YFAF	67	100L2-4	61
67	430	20.90	12700	1.90	YF	67	100L2-4	57
77	375	18.29	12900	2.2	YFF	67	100L2-4	63
85	335	16.48	13000	2.4				
97	295	14.46	13000	2.8				
56	510	24.96	7440	1.15				
66	435	21.17	7340	1.40				
73	390	19.11	7260	1.55	YFA	57	100L2-4	51
83	345	16.81	7140	1.75	YFAF	57	100L2-4	56
88	325	15.88	7080	1.85	YF	57	100L2-4	51
104	275	13.52	6890	2.2	YFF	57	100L2-4	58
114	250	12.29	6780	2.4				
132	220	10.64	6590	2.8				
71	405	19.70	4750	1.00				
81	355	17.33	4760	1.15	YFA	47	100L2-4	42
86	335	16.36	4760	1.20	YFAF	47	100L2-4	44
100	285	13.93	4740	1.40	YF	47	100L2-4	42
111	260	12.66	4700	1.55	YFF	47	100L2-4	46
128	225	10.97	4640	1.80				
156	183	8.96	4370	1.80				
126	225	11.08	2320	0.85	YFA	37	100L2-4	37
134	215	10.42	2350	0.85	YFAF	37	100L2-4	39
156	184	8.97	2390	0.95	YF	37	100L2-4	38
175	164	8.01	2410	1.05	YFF	37	100L2-4	40
208	138	6.74	2290	1.00				
231	124	6.05	2300	1.10	YFA	37	100L2-4	37
269	107	5.21	2290	1.15	YFAF	37	100L2-4	39
286	100	4.90	2280	1.20	YF	37	100L2-4	38
332	86	4.22	2250	1.25	YFF	37	100L2-4	40
372	77	3.77	2220	1.35				



技术参数

Technical Data

P <sub>1</sub> = 4.0kW								
N <sub>A</sub> rpm	M <sub>2</sub> Nm	i	Fr <sub>2</sub> MAX[N]	f <sub>s</sub>	Type	Gear unit	Motor size	 Kg
1.7	20800	845	90700	0.85				
1.9	18800	764	97800	0.95				
2.1	16700	680	103900	1.10				
2.5	14100	576	110100	1.30	YFA	157 YR97	112M-4	790
3.2	11000	446	115700	1.65	YFAF	157 YR97	112M-4	850
4.7	7460	302	120000	2.4	YF	157 YR97	112M-4	810
5.2	6720	273	120000	2.7	YFF	157 YR97	112M-4	920
6.1	5660	232	120000	3.2				
7.2	4800	197	120000	3.8				
2.6	13800	549	87000	0.85	YFA	127 YR77	112M-4	455
2.9	12400	495	89700	0.95	YFAF	127 YR77	112M-4	490
3.3	10700	428	90000	1.10	YF	127 YR77	112M-4	490
3.8	9410	376	90000	1.30	YFF	127 YR77	112M-4	530
4.3	8350	333	48000	0.90	YFA	107 YR77	112M-4	300
4.9	7300	291	50800	1.05	YFAF	107 YR77	112M-4	325
5.6	6400	255	53100	1.20	YF	107 YR77	112M-4	320
					YFF	107 YR77	112M-4	345
4.2	9060	170.83	90000	1.30	YFA	127	160M1-8	445
4.7	8150	153.67	90000	1.45	YFAF	127	160M1-8	485
5.7	6650	125.37	90000	1.80	YF	127	160M1-8	485
					YFF	127	160M1-8	530
5.6	6840	254.40	52000	1.10				
6.6	5790	215.37	54500	1.35				
7.1	5360	199.31	55500	1.45				
8.0	4810	178.64	56700	1.60	YFA	107	112M-4	265
8.8	4340	161.28	57700	1.75	YFAF	107	112M-4	285
9.7	3940	146.49	58500	1.95	YF	107	112M-4	280
11	3500	129.97	59400	2.2	YFF	107	112M-4	305
12	3170	117.94	60100	2.4				
14	2730	101.38	60900	2.8				
8.1	4700	174.87	26600	0.90	YFA	97	112M-4	190
9.1	4200	156.30	30200	1.00	YFAF	97	112M-4	210
10	3780	140.71	31400	1.15	YF	97	112M-4	195
11	3430	127.42	32300	1.25	YFF	97	112M-4	230



技术参数

Technical Data

P <sub>1</sub> = 4.0kW								
Na rpm	M <sub>2</sub> Nm	i	Fr <sub>2</sub> MAX[N]	f <sub>s</sub>	Type	Gear unit	Motor size	 Kg
13	3040	112.99	33200	1.40				
14	2750	102.16	33900	1.55				
15	2620	97.58	34100	1.65	YFA	97	112M-4	190
16	2420	89.85	34600	1.80	YFAF	97	112M-4	210
18	2160	80.31	35100	2.0	YF	97	112M-4	195
20	1940	72.29	35500	2.2	YFF	97	112M-4	230
22	1760	65.47	35800	2.4				
13	2950	109.49	21700	1.00	YFA	87	112M-4	125
15	2630	97.89	24300	1.15	YFAF	87	112M-4	135
16	2370	88.01	24600	1.25	YF	87	112M-4	130
					YFF	87	112M-4	145
19	2050	76.39	24200	1.45	YFA	87	112M-4	125
21	1840	68.40	23900	1.65	YFAF	87	112M-4	135
25	1530	56.75	23200	1.95	YF	87	112M-4	130
28	1350	50.36	22800	2.2	YFF	87	112M-4	145
31	1220	45.28	22300	2.3				
21	1790	66.46	13400	0.85	YFA	77	112M-4	84
24	1570	58.32	15200	0.95	YFAF	77	112M-4	91
26	1490	55.27	15800	1.00	YF	77	112M-4	88
29	1300	48.37	16900	1.15	YFF	77	112M-4	99
33	1170	43.58	17600	1.30	YFA	77	112M-4	84
37	1030	38.23	18200	1.45	YFAF	77	112M-4	91
42	910	33.74	18600	1.65	YF	77	112M-4	88
47	800	29.91	19000	1.85	YFF	77	112M-4	99
56	685	25.54	19300	2.1				
45	850	31.51	18800	1.65	YFA	77	112M-4	83
49	775	28.75	19100	1.85	YFAF	77	112M-4	89
56	685	25.50	19300	2.2	YF	77	112M-4	87
66	575	21.43	19500	2.6	YFF	77	112M-4	97
72	530	19.70	19600	2.8				
52	735	27.41	11000	1.10				
57	675	25.13	11400	1.20				
64	595	22.05	11900	1.40				
68	560	20.90	12100	1.45				
78	490	18.29	12400	1.65	YFA	67	112M-4	61
86	445	16.48	12700	1.85	YFAF	67	112M-4	68
98	390	14.46	12900	2.1	YF	67	112M-4	64
111	345	12.76	13000	2.4	YFF	67	112M-4	70
126	305	11.31	13000	2.7				
147	260	9.66	13000	3.2				
156	245	9.08	13000	2.2				
165	230	8.60	12800	2.5				



技术参数

Technical Data

<b>P<sub>1</sub> = 4.0kW</b>								
------------------------------	--	--	--	--	--	--	--	--

N <sub>A</sub> rpm	M <sub>2</sub> Nm	i	Fr <sub>2MAX</sub> [N]	f <sub>s</sub>	Type	Gear unit	Motor size	Kg
189	205	7.53	12400	3.0				
209	183	6.78	12100	3.4	YFA	67	112M-4	61
239	160	5.95	11700	3.8	YFAF	67	112M-4	68
270	141	5.25	11400	4.2	YF	67	112M-4	64
305	125	4.66	11000	4.5	YFF	67	112M-4	70
357	107	3.97	10600	4.7				
<hr/>								
67	570	21.17	6490	1.05				
74	515	19.11	6490	1.15				
84	450	16.81	6450	1.35				
89	425	15.88	6430	1.40				
105	365	13.52	6340	1.65	YFA	57	112M-4	58
116	330	12.29	6270	1.80	YFAF	57	112M-4	63
133	285	10.64	6150	2.1	YF	57	112M-4	58
153	250	9.31	5850	1.70	YFF	57	112M-4	65
173	220	8.19	5730	1.90				
184	210	7.73	5680	2.0				
216	177	6.58	5510	2.4				
237	161	5.98	5410	2.6				
274	139	5.18	5250	3.0				

<b>P<sub>1</sub> = 5.5kW</b>								
------------------------------	--	--	--	--	--	--	--	--

2.5	19400	576	95800	0.95				
2.8	16900	503	103400	1.05				
3.2	15100	446	107800	1.20				
4.1	11800	353	114400	1.50	YFA	157 YR97	132S-4	800
4.7	10300	302	116900	1.75	YFAF	157 YR97	132S-4	850
5.2	9250	273	118300	1.95	YF	157 YR97	132S-4	820
6.2	7810	232	120000	2.3	YFF	157 YR97	132S-4	920
7.1	6790	202	120000	2.7				
7.3	6620	197	120000	2.7				
<hr/>								
3.4	14200	418	86100	0.85				
3.8	12700	374	89000	0.95	YFA	127 YR87	132S-4	480
4.6	10600	312	90000	1.15	YFAF	127 YR87	132S-4	520
4.9	9950	293	90000	1.20	YF	127 YR87	132S-4	520
5.5	8780	259	90000	1.35	YFF	127 YR87	132S-4	560
6.4	7580	223	90000	1.60				
<hr/>								
3.3	14700	428	85200	0.80	YFA	127 YR77	132S-4	460
3.8	12900	376	88700	0.95	YFAF	127 YR77	132S-4	495
					YF	127 YR77	132S-4	495
					YFF	127 YR77	132S-4	540



技术参数

Technical Data

P <sub>1</sub> = 5.5kW								
NA rpm	M <sub>2</sub> Nm	i	Fr <sub>2</sub> MAX[N]	f <sub>s</sub>	Type	Gear unit	Motor size	 Kg
2.6	19800	267.43	94600	0.90				
3.3	16100	217.62	105500	1.10				
4.0	13200	178.20	111900	1.35				
4.4	12100	162.96	114000	1.50				
5.0	10500	141.80	116600	1.70	YFA	157	160M2-8	710
5.7	9260	125.14	118300	1.95	YFAF	157	160M2-8	770
6.5	8030	108.49	119700	2.2	YF	157	160M2-8	730
7.4	7140	96.53	120000	2.5	YFF	157	160M2-8	840
8.3	6350	85.80	120000	2.8				
9.1	5800	78.46	120000	3.1				
10	5050	68.28	120000	3.6				
4.2	12600	170.83	89200	0.95	YFA	127	160M2-8	450
4.6	11400	153.67	90000	1.05	YFAF	127	160M2-8	490
5.7	9270	125.37	90000	1.30	YF	127	160M2-8	485
6.2	8460	114.34	90000	1.40	YFF	127	160M2-8	530
6.6	7910	215.37	49200	0.95	YFA	107	132S-4	270
7.2	7320	199.31	50800	1.05	YFAF	107	132S-4	290
8.0	6560	178.64	52700	1.15	YF	107	132S-4	285
8.9	5920	161.28	54200	1.30	YFF	107	132S-4	315
9.8	5380	146.49	55500	1.45				
11	4770	129.97	56800	1.60				
12	4330	117.94	57700	1.75	YFA	107	132S-4	270
14	3720	101.38	59000	2.1	YFAF	107	132S-4	290
15	3400	92.47	59600	2.3	YF	107	132S-4	285
16	3250	88.49	59900	2.4	YFF	107	132S-4	315
17	3080	83.99	60200	2.5				
11	4680	127.42	27400	0.90	YFA	97	132S-4	195
13	4150	112.99	30300	1.05	YFAF	97	132S-4	215
14	3750	102.16	31400	1.15	YF	97	132S-4	200
					YFF	97	132S-4	235
15	3580	97.58	31900	1.20				
16	3300	89.85	32600	1.30				
17	3180	86.59	32900	1.35				
18	2950	80.31	33400	1.45	YFA	97	132S-4	195
19	2780	75.63	33800	1.55	YFAF	97	132S-4	215
20	2660	72.29	34100	1.60	YF	97	132S-4	200
22	2400	65.47	34600	1.80	YFF	97	132S-4	235
25	2130	58.06	34500	2.0				
27	1930	52.49	33900	2.2				
16	3230	88.01	5760	0.95	YFA	87	132S-4	130
19	2810	76.39	21200	1.05	YFAF	87	132S-4	140
21	2510	68.40	21200	1.20	YF	87	132S-4	135
25	2080	56.75	21000	1.45	YFF	87	132S-4	150



技术参数

Technical Data

P <sub>1</sub> = 5.5kW								
N <sub>A</sub> rpm	M <sub>2</sub> Nm	i	Fr <sub>2</sub> MAX[N]	f <sub>s</sub>	Type	Gear unit	Motor size	 Kg
28	1850	50.36	20800	1.60	YFA	87	132S-4	130
32	1660	45.28	20500	1.70	YFAF	87	132S-4	140
36	1440	39.30	20100	1.90	YF	87	132S-4	135
41	1290	35.19	19800	2.0	YFF	87	132S-4	150
49	1070	29.20	19100	2.3				
42	1250	33.92	19700	2.1	YFA	87	132S-4	125
50	1060	28.78	19100	2.3	YFAF	87	132S-4	140
54	970	26.50	18800	3.1	YF	87	132S-4	130
60	870	23.68	18400	3.5	YFF	87	132S-4	145
30	1780	48.37	13500	0.85				
33	1600	43.58	15000	0.95	YFA	77	132S-4	91
37	1400	38.23	16300	1.05	YFAF	77	132S-4	98
42	1240	33.74	17300	1.20	YF	77	132S-4	95
48	1100	29.91	17900	1.35	YFF	77	132S-4	105
56	940	25.54	18500	1.55				
56	940	25.50	18500	1.60				
67	785	21.43	19000	1.90	YFA	77	132S-4	90
73	725	19.70	19200	2.1	YFAF	77	132S-4	96
82	645	17.49	19400	2.3	YF	77	132S-4	94
91	575	15.64	19600	2.6	YFF	77	132S-4	105
102	515	14.06	19300	2.9				
117	450	12.20	18600	3.4				
65	810	22.05	10400	1.00				
68	770	20.90	10800	1.05				
78	670	18.29	11500	1.20				
87	605	16.48	11900	1.35				
99	530	14.46	12300	1.55				
112	470	12.76	12500	1.75				
126	415	11.31	12800	1.95	YFA	67	132S-4	66
148	355	9.66	12900	2.3	YFAF	67	132S-4	73
158	335	9.08	12400	1.60	YF	67	132S-4	69
166	315	8.60	12300	1.80	YFF	67	132S-4	75
190	275	7.53	12000	2.2				
211	250	6.78	11700	2.5				
240	220	5.95	11400	2.8				
272	193	5.25	11100	3.1				
307	171	4.66	10700	3.3				
360	146	3.97	10300	3.4				
85	620	16.81	5450	0.95	YFA	57	132S-4	63
90	585	15.88	5480	1.05	YFAF	57	132S-4	68
106	495	13.52	5530	1.20	YF	57	132S-4	63
116	450	12.29	5530	1.35	YFF	57	132S-4	70
134	390	10.64	5510	1.55				



技术参数

Technical Data

<b>P<sub>1</sub> = 5.5kW</b>								
------------------------------	--	--	--	--	--	--	--	--

N <sub>A</sub> rpm	M <sub>2</sub> Nm	i	Fr <sub>2</sub> MAX[N]	f <sub>s</sub>	Type	Gear unit	Motor size	Kg
175	300	8.19	5190	1.40	YFA	57	132S-4	63
185	285	7.73	5160	1.50	YFAF	57	132S-4	68
217	240	6.58	5070	1.75	YF	57	132S-4	63
239	220	5.98	5010	1.90	YFF	57	132S-4	70
276	190	5.18	4900	2.2				

<b>P<sub>1</sub> = 7.5kW</b>								
------------------------------	--	--	--	--	--	--	--	--

4.6	14500	312	85500	0.85	YFA	127 YR87	132M-4	500
4.9	13600	293	87300	0.90	YFAF	127 YR87	132M-4	540
5.5	12000	259	90000	1.00	YF	127 YR87	132M-4	540
6.4	10400	223	90000	1.15	YFF	127 YR87	132M-4	580
7.2	9190	198	90000	1.30				
3.3	21600	217.62	87600	0.85				
4.0	17700	178.20	101100	1.00				
4.4	16200	162.96	105200	1.10				
5.1	14100	141.80	110100	1.30				
5.8	12400	125.14	113300	1.45				
6.6	10800	108.49	116100	1.65	YFA	157	160L-8	740
7.5	9600	96.53	117800	1.85	YFAF	157	160L-8	800
8.4	8530	85.80	119200	2.1	YF	157	160L-8	760
9.2	7810	78.46	120000	2.3	YFF	157	160L-8	870
11	6790	68.28	120000	2.7				
12	5990	60.25	120000	3.0				
14	5200	52.24	120000	3.5				
15	4620	46.48	120000	3.9				
18	3980	40.06	120000	4.5				
3.6	20000	267.43	94000	0.90				
4.4	16200	217.62	105100	1.10				
5.4	13300	178.20	111700	1.35				
5.9	12200	162.96	113800	1.50				
6.8	10600	141.80	116400	1.70				
7.7	9340	125.14	118200	1.95	YFA	157	160M-6	710
8.8	8090	108.49	119700	2.2	YFAF	157	160M-6	770
10	7200	96.53	120000	2.5	YF	157	160M-6	730
11	6400	85.80	120000	2.8	YFF	157	160M-6	840
12	5850	78.46	120000	3.1				
14	5090	68.28	120000	3.5				
16	4500	60.25	120000	4.0				
18	3900	52.24	119300	4.6				
5.7	12500	125.37	89500	0.95	YFA	127	160L-8	485
6.3	11400	114.34	90000	1.05	YFAF	127	160L-8	520
7.3	9840	98.95	90000	1.20	YF	127	160L-8	520
8.2	8690	87.31	90000	1.40	YFF	127	160L-8	570



技术参数

Technical Data

P <sub>1</sub> = 7.5kW								
NA rpm	M <sub>2</sub> Nm	i	Fr <sub>2</sub> MAX[N]	f <sub>s</sub>	Type	Gear unit	Motor size	 Kg
5.6	12700	170.83	89000	0.95	YFA	127	160M-6	450
6.2	11500	153.67	90000	1.05	YFAF	127	160M-6	490
7.7	9350	125.37	90000	1.30	YF	127	160M-6	485
8.4	8530	114.34	90000	1.40	YFF	127	160M-6	530
8.4	8560	170.83	90000	1.40	YFA	127	132M-4	435
9.3	7700	153.67	90000	1.55	YFAF	127	132M-4	475
11	6280	125.37	90000	1.90	YF	127	132M-4	475
					YFF	127	132M-4	520
8.0	8950	178.64	46300	0.85	YFA	107	132M-4	290
8.9	8080	161.28	48700	0.95	YFAF	107	132M-4	310
9.8	7340	146.49	50700	1.05	YF	107	132M-4	305
11	6510	129.97	52800	1.20	YFF	107	132M-4	335
12	5910	117.94	54200	1.30				
14	5080	101.38	56100	1.50	YFA	107	132M-4	290
15	4630	92.47	57100	1.65	YFAF	107	132M-4	310
16	4430	88.49	57500	1.75	YF	107	132M-4	305
17	4210	83.99	58000	1.85	YFF	107	132M-4	335
19	3730	74.52	59000	2.1				
21	3390	67.62	59600	2.3				
15	4890	97.58	19300	0.90				
16	4500	89.85	29300	0.95	YFA	97	132M-4	215
17	4340	86.59	29800	1.00	YFAF	97	132M-4	235
18	4020	80.31	30700	1.05	YF	97	132M-4	220
19	3790	75.63	31300	1.15	YFF	97	132M-4	255
20	3620	72.29	31800	1.20				
22	3280	65.47	32200	1.30				
25	2910	58.06	31800	1.50	YFA	97	132M-4	215
27	2630	52.49	31400	1.65	YFAF	97	132M-4	235
32	2230	44.49	30600	1.95	YF	97	132M-4	220
37	1950	38.86	29900	2.2	YFF	97	132M-4	255
44	1630	32.50	28900	2.6				
33	2170	43.28	30500	1.40	YFA	97	132M-4	210
39	1840	36.64	29600	1.65	YFAF	97	132M-4	230
42	1700	33.91	29200	2.5	YF	97	132M-4	215
47	1520	30.39	28500	2.8	YFF	97	132M-4	250
25	2840	56.75	18100	1.05				
28	2520	50.36	18200	1.15	YFA	87	132M-4	150
32	2270	45.28	18200	1.25	YFAF	87	132M-4	165
36	1970	39.30	18100	1.40	YF	87	132M-4	155
41	1760	35.19	18000	1.50	YFF	87	132M-4	170
49	1460	29.20	17600	1.70				



技术参数

Technical Data

<b>P<sub>1</sub> = 7.5kW</b>								
------------------------------	--	--	--	--	--	--	--	--

N <sub>A</sub> rpm	M <sub>2</sub> Nm	i	Fr <sub>2</sub> MAX[N]	f <sub>s</sub>	Type	Gear unit	Motor size	Kg
50	1440	28.78	17600	1.70				
54	1330	26.50	17400	2.3				
60	1190	23.68	17100	2.5	YFA	87	132M-4	150
67	1070	21.32	16800	2.8	YFAF	87	132M-4	160
74	970	19.31	16500	3.1	YF	87	132M-4	155
84	860	17.12	16200	3.5	YFF	87	132M-4	170
92	775	15.48	15900	3.9				
<hr/>								
42	1690	33.74	14300	0.90	YFA	77	132M-4	110
48	1500	29.91	15700	1.00	YFAF	77	132M-4	120
56	1280	25.54	17000	1.15	YF	77	132M-4	115
					YFF	77	132M-4	125
<hr/>								
56	1280	25.50	17100	1.15				
67	1070	21.43	18000	1.40				
73	990	19.70	18400	1.50				
82	880	17.49	18800	1.70				
91	785	15.64	19000	1.90				
102	705	14.06	18600	2.1	YFA	77	132M-4	110
117	610	12.20	18000	2.5	YFAF	77	132M-4	115
131	545	10.93	17600	2.7	YF	77	132M-4	115
154	465	9.30	16500	2.3	YFF	77	132M-4	125
173	415	8.26	16100	2.6				
194	370	7.39	15700	2.9				
215	335	6.64	15300	3.3				
248	290	5.76	14800	3.7				
277	260	5.16	14500	4.2				
334	215	4.28	13800	4.7				

<b>P<sub>1</sub> = 11kW</b>								
-----------------------------	--	--	--	--	--	--	--	--

4.8	20600	302	91800	0.90				
5.3	18600	273	98600	0.95	YFA	157 YR97	160M-4	830
6.2	15700	232	106400	1.15	YFAF	157 YR97	160M-4	890
7.1	13700	202	110900	1.30	YF	157 YR97	160M-4	850
7.3	13300	197	111700	1.35	YFF	157 YR97	160M-4	960
<hr/>								
6.5	15200	223	84100	0.80	YFA	127 YR87	160M-4	510
7.3	13400	198	87700	0.90	YFAF	127 YR87	160M-4	550
8.7	11300	166	90000	1.05	YF	127 YR87	160M-4	550
					YFF	127 YR87	160M-4	600



技术参数

Technical Data

P <sub>1</sub> = 11 kW								
N <sub>A</sub> rpm	M <sub>2</sub> Nm	i	Fr <sub>2</sub> MAX[N]	f <sub>s</sub>	Type	Gear unit	Motor size	 Kg
5.1	20700	141.80	91300	0.85	YFA	157	180L-8	780
5.8	18300	125.14	99500	1.00	YFAF	157	180L-8	840
6.6	15800	108.49	106100	1.15	YF	157	180L-8	800
7.5	14100	96.53	110100	1.30	YFF	157	180L-8	910
5.4	19500	178.20	95500	0.90				
5.9	17800	162.96	100800	1.00				
6.8	15500	141.80	106900	1.15	YFA	157	160L-6	740
7.7	13700	125.14	110900	1.30	YFAF	157	160L-6	800
8.8	11900	108.49	114300	1.50	YF	157	160L-6	760
10	10600	96.53	116400	1.70	YFF	157	160L-6	870
11	9390	85.80	118100	1.90				
12	8590	78.46	119100	2.1				
5.4	19500	267.43	95500	0.90				
6.6	15900	217.62	106000	1.15				
8.1	13000	178.20	112300	1.40				
8.8	11900	162.96	114300	1.50	YFA	157	160M-4	710
10	10300	141.80	116800	1.75	YFAF	157	160M-4	770
12	9130	125.14	118400	1.95	YF	157	160M-4	730
13	7910	108.49	119900	2.3	YFF	157	160M-4	840
15	7040	96.53	120000	2.6				
17	6260	85.80	118100	2.9				
18	5720	78.46	115700	3.1				
21	4980	68.28	112000	3.6				
7.7	13700	125.37	87100	0.85	YFA	127	160L-6	485
8.4	12500	114.34	89500	0.95	YFAF	127	160L-6	520
9.7	10800	98.95	90000	1.10	YF	127	160L-6	520
11	9550	87.31	90000	1.25	YFF	127	160L-6	570
13	8250	75.41	90000	1.45				
8.4	12500	170.83	89500	0.95				
9.4	11200	153.67	90000	1.05	YFA	127	160M-4	450
11	9150	125.37	90000	1.30	YFAF	127	160M-4	490
13	8340	114.34	90000	1.45	YF	127	160M-4	485
15	7220	98.95	90000	1.65	YFF	127	160M-4	530
16	6370	87.31	90000	1.90				
19	5500	75.41	88600	2.2				



技术参数

Technical Data

P <sub>1</sub> = 11.0kW								
N <sub>A</sub> rpm	M <sub>2</sub> Nm	i	Fr <sub>2</sub> MAX[N]	f <sub>s</sub>	Type	Gear unit	Motor size	 Kg
12	8600	117.94	47300	0.90	YFA	107	160M-4	305
14	7400	101.38	50600	1.05	YFAF	107	160M-4	325
16	6750	92.47	52200	1.15	YF	107	160M-4	320
					YFF	107	160M-4	345
17	6130	83.99	53700	1.25				
19	5440	74.52	55300	1.40	YFA	107	160M-4	305
21	4930	67.62	56500	1.55	YFAF	107	160M-4	325
25	4240	58.12	56400	1.80	YF	107	160M-4	320
28	3700	50.73	55100	2.1	YFF	107	160M-4	345
33	3140	43.03	53500	2.5				
43	2470	33.79	51000	3.0	YFA	107	160M-4	295
52	2010	27.57	48800	3.9	YFAF	107	160M-4	315
57	1830	25.14	47800	4.3	YF	107	160M-4	310
					YFF	107	160M-4	335
22	4780	65.47	24000	0.90	YFA	97	160M-4	230
25	4240	58.06	27100	1.00	YFAF	97	160M-4	250
27	3830	52.49	27100	1.10	YF	97	160M-4	235
					YFF	97	160M-4	270
32	3250	44.49	27000	1.30	YFA	97	160M-4	230
37	2830	38.86	26700	1.50	YFAF	97	160M-4	250
44	2370	32.50	26200	1.80	YF	97	160M-4	235
					YFF	97	160M-4	270
42	2470	33.91	26400	1.75	YFA	97	160M-4	225
47	2220	30.39	26000	1.95	YFAF	97	160M-4	245
52	2000	27.44	25600	2.2	YF	97	160M-4	230
58	1820	24.92	25200	2.4	YFF	97	160M-4	265
65	1610	22.11	24700	2.7				



技术参数

Technical Data

<b>P<sub>1</sub> = 11.0kW</b>								
-------------------------------	--	--	--	--	--	--	--	--

N <sub>A</sub> rpm	M <sub>2</sub> Nm	i	Fr <sub>2</sub> MAX[N]	f <sub>s</sub>	Type	Gear unit	Motor size	Kg
37	2870	39.30	14600	0.95	YFA	87	160M-4	165
41	2570	35.19	14800	1.00	YFAF	87	160M-4	175
49	2130	29.20	15000	1.20	YF	87	160M-4	170
					YFF	87	160M-4	185
54	1930	26.50	15000	1.55				
61	1730	23.68	15000	1.75	YFA	87	160M-4	160
68	1560	21.32	14900	1.95	YFAF	87	160M-4	175
75	1410	19.31	14800	2.1	YF	87	160M-4	165
84	1250	17.12	14600	2.4	YFF	87	160M-4	180
93	1130	15.48	14400	2.7				
110	960	13.12	14100	3.1				
73	1440	19.70	16100	1.05				
82	1280	17.49	17100	1.20				
92	1140	15.64	17600	1.30				
102	1030	14.06	17400	1.45				
118	890	12.20	17000	1.70	YFA	77	160M-4	125
132	795	10.93	16700	1.90	YFAF	77	160M-4	130
155	680	9.30	15500	1.60	YF	77	160M-4	130
174	605	8.26	15200	1.80	YFF	77	160M-4	140
195	540	7.39	14900	2.0				
217	485	6.64	14600	2.2				
250	420	5.76	14200	2.6				
279	375	5.16	13900	2.9				
336	310	4.28	13300	3.2				

<b>P<sub>1</sub> = 15.0kW</b>								
-------------------------------	--	--	--	--	--	--	--	--

6.3	21200	232	89400	0.85	YFA	157 YR97	160L-4	870
7.2	18500	202	98800	0.95	YFAF	157 YR97	160L-4	930
7.4	18000	197	100400	1.00	YF	157 YR97	160L-4	890
					YFF	157 YR97	160L-4	1000
6.8	20900	141.80	90400	0.85	YFA	157	180L-6	780
7.8	18500	125.14	98800	0.95	YFAF	157	180L-6	840
8.9	16000	108.49	105700	1.10	YF	157	180L-6	800
10	14300	96.53	109800	1.25	YFF	157	180L-6	910
11	12700	85.80	112900	1.40				
6.7	21400	217.62	88800	0.85				
8.2	17500	178.20	101800	1.05	YFA	157	160L-4	740
9.0	16000	162.96	105700	1.15	YFAF	157	160L-4	800
10	13900	141.80	110500	1.30	YF	157	160L-4	760
12	12300	125.14	113600	1.45	YFF	157	160L-4	870
13	10600	108.49	116300	1.70				
15	9470	96.53	115800	1.90				



技术参数

Technical Data

P <sub>1</sub> = 15.0kW								
Na rpm	M <sub>2</sub> Nm	i	Fr <sub>2</sub> MAX[N]	f <sub>s</sub>	Type	Gear unit	Motor size	 Kg
17	8420	85.80	113200	2.1	YFA	157	160L-4	740
19	7700	78.46	111200	2.3	YFAF	157	160L-4	800
21	6700	68.28	108000	2.7	YF	157	160L-4	760
24	5910	60.25	105100	3.1	YFF	157	160L-4	870
9.8	14600	98.95	85300	0.80	YFA	127	180L-6	520
11	12900	87.31	88700	0.95	YFAF	127	180L-6	560
13	11100	75.41	88300	1.10	YF	127	180L-6	560
14	10300	70.07	87600	1.15	YFF	127	180L-6	600
15	9440	63.91	86700	1.25				
12	12300	125.37	89000	1.00	YFA	127	160L-4	485
13	11200	114.34	88300	1.05	YFAF	127	160L-4	520
15	9710	98.95	87000	1.25	YF	127	160L-4	520
17	8570	87.31	85600	1.40	YFF	127	160L-4	570
19	7400	75.41	83800	1.60				
21	6870	70.07	82800	1.75				
16	9070	92.47	45900	0.85	YFA	107	160L-4	345
17	8680	88.49	47100	0.90	YFAF	107	160L-4	365
17	8240	83.99	48300	0.95	YF	107	160L-4	360
20	7310	74.52	50800	1.05	YFF	107	160L-4	390
22	6630	67.62	52500	1.15				
25	5700	58.12	52200	1.35	YFA	107	160L-4	345
29	4980	50.73	51500	1.55	YFAF	107	160L-4	365
34	4220	43.03	50400	1.80	YF	107	160L-4	360
39	3690	37.61	49300	2.1	YFF	107	160L-4	390
46	3120	31.80	48000	2.5				
43	3320	33.79	48500	2.2	YFA	107	160L-4	335
53	2700	27.57	46700	2.9	YFAF	107	160L-4	355
58	2470	25.14	45900	3.2	YF	107	160L-4	350
67	2130	21.76	44500	3.7	YFF	107	160L-4	380
33	4360	44.49	22900	1.00	YFA	97	160L-4	270
38	3810	38.86	23100	1.15	YFAF	97	160L-4	290
45	3190	32.50	23200	1.35	YF	97	160L-4	275
					YFF	97	160L-4	310
43	3330	33.91	23200	1.30				
48	2980	30.39	23200	1.45				
53	2690	27.44	23100	1.60				
59	2450	24.92	22900	1.75	YFA	97	160L-4	265
66	2170	22.11	22600	2.0	YFAF	97	160L-4	285
73	1970	20.07	22400	2.2	YF	97	160L-4	270
85	1690	17.25	21900	2.5	YFF	97	160L-4	305
97	1480	15.06	21400	2.9				
114	1250	12.77	20800	3.4				
131	1100	11.16	20200	3.7				



技术参数

Technical Data

<b>P<sub>1</sub> = 15.0kW</b>								
-------------------------------	--	--	--	--	--	--	--	--

N <sub>A</sub> rpm	M <sub>2</sub> Nm	i	Fr <sub>2</sub> MAX[N]	f <sub>s</sub>	Type	Gear unit	Motor size	Kg
55	2600	26.50	12300	1.15				
62	2320	23.68	12600	1.30				
68	2090	21.32	12700	1.45				
76	1890	19.31	12800	1.60				
85	1680	17.12	12900	1.80				
94	1520	15.48	12800	2.0				
111	1290	13.12	12700	2.3	YFA	87	160L-4	200
127	1120	11.46	12600	2.7	YFAF	87	160L-4	215
152	940	9.58	12300	3.1	YF	87	160L-4	205
176	810	8.29	11700	1.90	YFF	87	160L-4	220
199	720	7.35	11500	2.1				
220	650	6.65	11300	2.4				
259	555	5.63	11000	2.8				
297	485	4.92	10700	3.2				
355	405	4.12	10300	3.6				

<b>P<sub>1</sub> = 18.5kW</b>								
-------------------------------	--	--	--	--	--	--	--	--

7.2	22800	202	70200	0.80	YFA	157 YR97	180M-4	890
7.5	22100	197	83800	0.80	YFAF	157 YR97	180M-4	950
					YF	157 YR97	180M-4	910
					YFF	157 YR97	180M-4	1020
<hr/>								
8.2	21500	178.20	88200	0.85				
9.0	19700	162.96	95000	0.90				
10	17100	141.80	102800	1.05				
12	15100	125.14	107900	1.20				
14	13100	108.49	112100	1.40	YFA	157	180M-4	770
15	11600	96.53	111300	1.55	YFAF	157	180M-4	820
17	10300	85.80	109300	1.75	YF	157	180M-4	790
19	9460	78.46	107600	1.90	YFF	157	180M-4	890
21	8230	68.28	104900	2.2				
24	7270	60.25	102300	2.5				
28	6300	52.24	99300	2.9				
<hr/>								
13	13800	114.34	82200	0.85				
15	11900	98.95	81700	1.00				
17	10500	87.31	80900	1.15	YFA	127	180M-4	510
19	9090	75.41	79700	1.30	YFAF	127	180M-4	550
21	8450	70.07	79000	1.40	YF	127	180M-4	550
23	7710	63.91	78100	1.55	YFF	127	180M-4	590
26	6670	55.31	76400	1.80				
30	5880	48.80	74900	2.0				



技术参数

Technical Data

<b>P<sub>1</sub> = 18.5kW</b>								
-------------------------------	--	--	--	--	--	--	--	--

N <sub>A</sub> rpm	M <sub>2</sub> Nm	i	Fr <sub>2</sub> MAX[N]	f <sub>s</sub>	Type	Gear unit	Motor size	Kg
20	8990	74.52	46200	0.85	YFA	107	180M-4	365
22	8150	67.62	48500	0.95	YFAF	107	180M-4	385
25	7010	58.12	48700	1.10	YF	107	180M-4	380
29	6120	50.73	48400	1.25	YFF	107	180M-4	410
34	5190	43.03	47700	1.50	YFA	107	180M-4	365
39	4540	37.61	47000	1.70	YFAF	107	180M-4	385
46	3830	31.80	46000	2.0	YF	107	180M-4	380
					YFF	107	180M-4	410
43	4070	33.79	46400	1.80	YFA	107	180M-4	355
53	3320	27.57	45000	2.4	YFAF	107	180M-4	375
58	3030	25.14	44300	2.6	YF	107	180M-4	370
67	2620	21.76	43200	3.0	YFF	107	180M-4	400
38	4690	38.86	20000	0.90	YFA	97	180M-4	290
45	3920	32.50	20600	1.10	YFAF	97	180M-4	315
					YF	97	180M-4	300
					YFF	97	180M-4	330
53	3310	27.44	20900	1.30				
59	3010	24.92	20900	1.45				
66	2670	22.11	20900	1.60	YFA	97	180M-4	285
73	2420	20.07	20800	1.80	YFAF	97	180M-4	305
85	2080	17.25	20500	2.1	YF	97	180M-4	295
97	1820	15.06	20200	2.4	YFF	97	180M-4	325
115	1540	12.77	19800	2.8				
131	1350	11.16	19300	3.1				
69	2570	21.32	10900	1.15				
76	2330	19.31	11100	1.30				
86	2060	17.12	11400	1.45				
95	1870	15.48	11500	1.60				
112	1580	13.12	11600	1.90	YFA	87	180M-4	225
128	1380	11.46	11600	2.2	YFAF	87	180M-4	235
153	1160	9.58	11500	2.5	YF	87	180M-4	230
177	1000	8.29	10900	1.55	YFF	87	180M-4	245
199	890	7.35	10800	1.75				
220	800	6.65	10700	1.90				
260	680	5.63	10400	2.3				
298	595	4.92	10200	2.6				
356	495	4.12	9900	2.9				

<b>P<sub>1</sub> = 22kW</b>								
-----------------------------	--	--	--	--	--	--	--	--

10	20900	96.53	90500	0.85	YFA	157	200L2-6	860
11	18600	85.80	98500	0.95	YFAF	157	200L2-6	920
12	17000	78.46	103100	1.05	YF	157	200L2-6	880
14	14800	68.28	107700	1.20	YFF	157	200L2-6	990



技术参数

Technical Data

P <sub>1</sub> = 22kW								
NA rpm	M <sub>2</sub> Nm	i	Fr <sub>2</sub> MAX[N]	f <sub>s</sub>	Type	Gear unit	Motor size	 Kg
10	20300	141.80	92600	0.90				
12	17900	125.14	100400	1.00				
14	15600	108.49	106800	1.15				
15	13800	96.53	106900	1.30				
17	12300	85.80	105400	1.45	YFA	157	180L-4	780
19	11300	78.46	104000	1.60	YFAF	157	180L-4	840
21	9790	68.28	101700	1.85	YF	157	180L-4	800
24	8640	60.25	99600	2.1	YFF	157	180L-4	910
28	7490	52.24	97000	2.4				
32	6660	46.48	94800	2.7				
37	5740	40.06	91900	3.1				
45	4670	32.55	87800	3.9				
15	14200	98.95	76400	0.85				
17	12500	87.31	76300	0.95				
19	10800	75.41	75700	1.10	YFA	127	180L-4	520
21	10000	70.07	75300	1.20	YFAF	127	180L-4	560
23	9160	63.91	74700	1.30	YF	127	180L-4	560
26	7930	55.31	73500	1.50	YFF	127	180L-4	600
30	7000	48.80	72300	1.70				
35	6040	42.15	70700	2.0				
25	8330	58.12	45200	0.90	YFA	107	180L-4	380
29	7280	50.73	45300	1.05	YFAF	107	180L-4	400
34	6170	43.03	45100	1.25	YF	107	180L-4	395
					YFF	107	180L-4	425
39	5390	37.61	44800	1.40	YFA	107	180L-4	380
46	4560	31.80	44100	1.70	YFAF	107	180L-4	400
					YF	107	180L-4	395
					YFF	107	180L-4	425
43	4850	33.79	44300	1.55	YFA	107	180L-4	370
53	3950	27.57	43300	2.0	YFAF	107	180L-4	390
58	3610	25.14	42800	2.2	YF	107	180L-4	385
67	3120	21.76	41900	2.5	YFF	107	180L-4	415
76	2750	19.20	41000	2.9				
53	3940	27.44	18700	1.10				
59	3570	24.92	18900	1.20				
66	3170	22.11	19100	1.35	YFA	97	180L-4	300
73	2880	20.07	19200	1.50	YFAF	97	180L-4	320
85	2470	17.25	19100	1.75	YF	97	180L-4	305
97	2160	15.06	19000	2.0	YFF	97	180L-4	340
115	1830	12.77	18700	2.4				
131	1600	11.16	18400	2.6				



技术参数

Technical Data

<b>P<sub>1</sub> = 22kW</b>								
-----------------------------	--	--	--	--	--	--	--	--

N <sub>A</sub> rpm	M <sub>2</sub> Nm	i	Fr <sub>2</sub> MAX[N]	f <sub>s</sub>	Type	Gear unit	Motor size	Kg
69	3060	21.32	8990	1.00				
76	2770	19.31	9430	1.10				
86	2460	17.12	9850	1.20				
95	2220	15.48	10100	1.35				
112	1880	13.12	10400	1.60				
128	1640	11.46	10600	1.85	YFA	87	180L-4	235
153	1370	9.58	10600	2.1	YFAF	87	180L-4	250
177	1190	8.29	10100	1.30	YF	87	180L-4	240
199	1050	7.35	10100	1.45	YFF	87	180L-4	260
220	950	6.65	10000	1.60				
260	810	5.63	9900	1.90				
298	705	4.92	9750	2.2				
356	590	4.12	9500	2.5				

<b>P<sub>1</sub> = 30kW</b>								
-----------------------------	--	--	--	--	--	--	--	--

14	21100	108.49	89600	0.85				
15	18800	96.53	96900	0.95				
17	16700	85.80	96400	1.10				
19	15300	78.46	95800	1.20	YFA	157	200L-4	860
22	13300	68.28	94600	1.35	YFAF	157	200L-4	920
24	11700	60.25	93300	1.55	YF	157	200L-4	880
28	10200	52.24	91500	1.75	YFF	157	200L-4	990
32	9060	46.48	89900	2.0				
37	7810	40.06	87700	2.3				
<hr/>								
19	14700	75.41	66600	0.80				
21	13700	70.07	66800	0.90				
23	12500	63.91	66900	0.95				
27	10800	55.31	66700	1.10	YFA	127	200L-4	610
30	9510	48.80	66300	1.25	YFAF	127	200L-4	650
35	8210	42.15	65500	1.45	YF	127	200L-4	650
39	7270	37.28	64700	1.65	YFF	127	200L-4	690
47	6110	31.33	63200	1.95				
58	4930	25.30	61200	2.4				
<hr/>								
55	5240	26.86	61800	1.60	YFA	127	200L-4	600
60	4790	24.57	60900	1.80	YFAF	127	200L-4	630
69	4170	21.38	59400	2.9	YF	127	200L-4	630
78	3680	18.87	58000	3.0	YFF	127	200L-4	680
<hr/>								
34	8390	43.03	39200	0.90	YFA	107	200L-4	465
39	7330	37.61	39600	1.05	YFAF	107	200L-4	485
46	6200	31.80	39700	1.25	YF	107	200L-4	480
					YFF	107	200L-4	510



技术参数

Technical Data

<b>P<sub>1</sub> = 30kW</b>								
-----------------------------	--	--	--	--	--	--	--	--

N <sub>A</sub> rpm	M <sub>2</sub> Nm	i	Fr <sub>2</sub> MAX[N]	f <sub>s</sub>	Type	Gear unit	Motor size	Kg
53	5370	27.57	39500	1.45				
58	4900	25.14	39300	1.60				
68	4240	21.76	38800	1.85	YFA	107	200L-4	455
77	3740	19.20	38300	2.1	YFAF	107	200L-4	475
89	3230	16.58	37600	2.4	YF	107	200L-4	470
100	2860	14.67	36900	2.7	YFF	107	200L-4	495
119	2400	12.33	35900	2.9				
148	1940	9.96	34500	3.4				
<hr/>								
66	4310	22.11	15100	1.00				
73	3910	20.07	15500	1.10				
85	3360	17.25	16000	1.30				
98	2930	15.06	16300	1.45				
115	2490	12.77	16400	1.75	YFA	97	200L-4	380
132	2180	11.16	16400	1.90	YFAF	97	200L-4	405
162	1770	9.06	15400	1.35	YF	97	200L-4	390
179	1600	8.22	15300	1.45	YFF	97	200L-4	420
208	1380	7.07	15100	1.70				
238	1200	6.17	14900	1.85				
281	1020	5.23	14600	2.1				
321	890	4.57	14300	2.3				

<b>P<sub>1</sub> = 37kW</b>								
-----------------------------	--	--	--	--	--	--	--	--

17	20600	85.80	88600	0.85				
19	18900	78.46	88700	0.95				
22	16400	68.28	88400	1.10	YFA	157	225S-4	910
24	14500	60.25	87800	1.25	YFAF	157	225S-4	970
28	12600	52.24	86800	1.45	YF	157	225S-4	930
32	11200	46.48	85700	1.60	YFF	157	225S-4	1040
37	9630	40.06	84000	1.85				
45	7820	32.55	81400	2.3				
53	6630	27.60	79100	2.7				
<hr/>								
27	13300	55.31	60900	0.90	YFA	127	225S-4	660
30	11700	48.80	61100	1.00	YFAF	127	225S-4	690
35	10100	42.15	61100	1.20	YF	127	225S-4	690
39	8960	37.28	60700	1.35	YFF	127	225S-4	740
47	7530	31.33	59900	1.60				
58	6080	25.30	58500	1.95				
<hr/>								
55	6460	26.86	58900	1.30	YFA	127	225S-4	650
60	5910	24.57	58300	1.45	YFAF	127	225S-4	680
69	5140	21.38	57100	2.3	YF	127	225S-4	680
78	4530	18.87	56000	2.4	YFF	127	225S-4	730
90	3930	16.36	54600	2.8				



技术参数

Technical Data

<b>P<sub>1</sub> = 37kW</b>								
-----------------------------	--	--	--	--	--	--	--	--

N <sub>A</sub> rpm	M <sub>2</sub> Nm	i	Fr <sub>2</sub> MAX[N]	f <sub>s</sub>	Type	Gear unit	Motor size	Kg
101	3500	14.55	53400	3.1	YFA	127	225S-4	650
117	3010	12.54	51900	3.3	YFAF	127	225S-4	680
144	2450	10.19	49600	3.9	YF	127	225S-4	680
166	2130	8.86	47700	3.3	YFF	127	225S-4	730
186	1890	7.88	46500	3.2				
<hr/>								
53	6630	27.57	36200	1.20				
58	6040	25.14	36200	1.30				
68	5230	21.76	36200	1.50				
77	4610	19.20	36000	1.70				
89	3990	16.58	35600	1.95	YFA	107	225S-4	500
100	3530	14.67	35100	2.2	YFAF	107	225S-4	520
119	2960	12.33	34400	2.4	YF	107	225S-4	520
148	2390	9.96	33300	2.7	YFF	107	225S-4	550
152	2330	9.69	32400	2.1				
176	2010	8.37	31700	2.4				
199	1780	7.40	31000	2.6				
236	1500	6.22	30000	3.1				

<b>P<sub>1</sub> = 45kW</b>								
-----------------------------	--	--	--	--	--	--	--	--

22	20000	68.28	81300	0.90				
24	17600	60.25	81600	1.00	YFA	157	225M-4	940
28	15300	52.24	81300	1.20	YFAF	157	225M-4	1000
32	13600	46.48	80900	1.30	YF	157	225M-4	960
37	11700	40.06	79900	1.55	YFF	157	225M-4	1070
45	9510	32.55	78000	1.90				
53	8070	27.60	76200	2.2				
<hr/>								
30	14300	48.80	55200	0.85	YFA	127	225M-4	690
35	12300	42.15	56000	0.95	YFAF	127	225M-4	720
39	10900	37.28	56200	1.10	YF	127	225M-4	720
47	9160	31.33	56100	1.30	YFF	127	225M-4	770
58	7400	25.30	55400	1.60				
<hr/>								
55	7850	26.86	55700	1.10				
60	7180	24.57	55300	1.20				
69	6250	21.38	54500	1.90				
78	5520	18.87	53700	2.0				
90	4780	16.36	52600	2.3	YFA	127	225M-4	670
101	4250	14.55	51600	2.6	YFAF	127	225M-4	710
117	3670	12.54	50300	2.7	YF	127	225M-4	710
144	2980	10.19	48400	3.2	YFF	127	225M-4	760
166	2590	8.86	46600	2.7				
186	2300	7.88	45500	2.6				
216	1990	6.80	44000	3.5				
266	1610	5.52	42000	3.7				



技术参数

Technical Data

<b>P<sub>1</sub> = 45kW</b>								
-----------------------------	--	--	--	--	--	--	--	--

N <sub>A</sub> rpm	M <sub>2</sub> Nm	i	Fr <sub>2</sub> MAX[N]	f <sub>s</sub>	Type	Gear unit	Motor size	Kg
53	8060	27.57	32400	0.95				
58	7350	25.14	32800	1.05				
68	6360	21.76	33200	1.25				
77	5610	19.20	33300	1.40				
89	4850	16.58	33300	1.60	YFA	107	225M-4	530
100	4290	14.67	33100	1.80	YFAF	107	225M-4	550
119	3600	12.33	32700	1.95	YF	107	225M-4	550
148	2910	9.96	31900	2.2	YFF	107	225M-4	570
152	2830	9.69	31000	1.75				
176	2450	8.37	30400	1.95				
199	2160	7.40	29900	2.1				
236	1820	6.22	29100	2.5				

<b>P<sub>1</sub> = 55kW</b>								
-----------------------------	--	--	--	--	--	--	--	--

24	21500	60.25	73800	0.85				
28	18600	52.24	74600	0.95	YFA	157	250M-4	1070
32	16500	46.48	74800	1.10	YFAF	157	250M-4	1130
37	14300	40.06	74700	1.25	YF	157	250M-4	1090
45	11600	32.55	73800	1.55	YFF	157	250M-4	1200
53	9830	27.60	72600	1.85				
<hr/>								
52	10200	28.60	72900	1.65	YFA	157	250M-4	1060
58	9060	25.43	71900	1.65	YFAF	157	250M-4	1120
67	7890	22.16	70600	2.3	YF	157	250M-4	1080
75	7040	19.77	69400	2.4	YFF	157	250M-4	1190
88	6000	16.85	67600	3.0				
<hr/>								
40	13300	37.28	50600	0.90	YFA	127	250M-4	810
47	11200	31.33	51400	1.10	YFAF	127	250M-4	850
58	9010	25.30	51600	1.35	YF	127	250M-4	840
					YFF	127	250M-4	890
<hr/>								
69	7610	21.38	51300	1.60				
78	6720	18.87	50800	1.65				
90	5820	16.36	50100	1.90				
101	5180	14.55	49400	2.1	YFA	127	250M-4	800
118	4470	12.54	48400	2.2	YFAF	127	250M-4	830
145	3630	10.19	46800	2.6	YF	127	250M-4	830
166	3160	8.86	45100	2.2	YFF	127	250M-4	880
187	2810	7.88	44200	2.1				
217	2420	6.80	42900	2.9				
267	1970	5.52	41100	3.1				
315	1670	4.68	39600	3.6				



技术参数

Technical Data

<b>P<sub>1</sub> = 75kW</b>								
-----------------------------	--	--	--	--	--	--	--	--

N <sub>A</sub> rpm	M <sub>2</sub> Nm	i	Fr <sub>2</sub> MAX[N]	f <sub>s</sub>	Type	Gear unit	Motor size	Kg
32	22500	46.48	62900	0.80	YFA	157	280S-4	1200
37	19400	40.06	64400	0.95	YFAF	157	280S-4	1260
45	15800	32.55	65400	1.15	YF	157	280S-4	1220
54	13400	27.60	65500	1.35	YFF	157	280S-4	1330
52	13800	28.60	65500	1.25				
58	12300	25.43	65400	1.20	YFA	157	280S-4	1190
67	10700	22.16	64900	1.70	YFAF	157	280S-4	1250
75	9570	19.77	64300	1.80	YF	157	280S-4	1220
88	8150	16.85	63200	2.2	YFF	157	280S-4	1320
106	6760	13.96	61600	2.5				
124	5770	11.92	60100	2.8				
58	12200	25.30	44000	1.00	YFA	127	280S-4	950
					YFAF	127	280S-4	980
					YF	127	280S-4	980
					YFF	127	280S-4	1030
69	10300	21.38	44800	1.15				
78	9130	18.87	45100	1.20				
90	7920	16.36	45200	1.40				
102	7040	14.55	45000	1.55	YFA	127	280S-4	940
118	6070	12.54	44600	1.65	YFAF	127	280S-4	970
145	4930	10.19	43700	1.95	YF	127	280S-4	970
167	4290	8.86	42200	1.65	YFF	127	280S-4	1020
188	3810	7.88	41600	1.55				
218	3290	6.80	40700	2.1				
268	2670	5.52	39300	2.3				
316	2270	4.68	38100	2.7				

<b>P<sub>1</sub> = 90kW</b>								
-----------------------------	--	--	--	--	--	--	--	--

45	18900	32.55	59100	0.95	YFA	157	280M-4	1280
54	16000	27.60	60200	1.10	YFAF	157	280M-4	1330
					YF	157	280M-4	1300
					YFF	157	280M-4	1400
52	16600	28.60	60000	1.00				
58	14800	25.43	60400	1.00	YFA	157	280M-4	1270
67	12900	22.16	60600	1.40	YFAF	157	280M-4	1330
75	11500	19.77	60500	1.50	YF	157	280M-4	1290
88	9790	16.85	59900	1.85	YFF	157	280M-4	1400
106	8110	13.96	58900	2.1				
124	6920	11.92	57800	2.3				
58	14700	25.30	33100	0.80	YFA	127	280M-4	1020
					YFAF	127	280M-4	1060
					YF	127	280M-4	1060
					YFF	127	280M-4	1100



技术参数

Technical Data

<b>P<sub>1</sub> = 90kW</b>								
-----------------------------	--	--	--	--	--	--	--	--

<b>N<sub>A</sub></b> rpm	<b>M<sub>2</sub></b> Nm	<b>i</b>	<b>Fr<sub>2MAX</sub>[N]</b>	<b>f<sub>s</sub></b>	<b>Type</b>	<b>Gear unit</b>	<b>Motor size</b>	 Kg
69	12400	21.38	38800	0.95				
78	11000	18.87	40900	1.00				
90	9500	16.36	41500	1.15				
102	8450	14.55	41700	1.30				
118	7280	12.54	41800	1.35	YFA	127	280M-4	1010
145	5920	10.19	41400	1.60	YFAF	127	280M-4	1050
167	5150	8.86	40100	1.35	YF	127	280M-4	1050
188	4580	7.88	39700	1.30	YFF	127	280M-4	1090
218	3950	6.80	39000	1.75				
268	3210	5.52	37900	1.85				
316	2720	4.68	36900	2.2				

<b>P<sub>1</sub> = 110kW</b>								
------------------------------	--	--	--	--	--	--	--	--

54	19500	27.60	53100	0.90	YFA	157	315S-4	1460
					YFAF	157	315S-4	1520
					YF	157	315S-4	1480
					YFF	157	315S-4	1590
67	15700	22.16	54900	1.15	YFA	157	315S-4	1460
75	14000	19.77	55400	1.20	YFAF	157	315S-4	1520
88	11900	16.85	55600	1.50	YF	157	315S-4	1480
106	9880	13.96	55300	1.70	YFF	157	315S-4	1580
125	8430	11.92	54700	1.90				

<b>P<sub>1</sub> = 132kW</b>								
------------------------------	--	--	--	--	--	--	--	--

67	18800	22.16	48700	0.95	YFA	157	315M1-4	1560
75	16800	19.77	49800	1.00	YFAF	157	315M1-4	1620
88	14300	16.85	50900	1.25	YF	157	315M1-4	1580
106	11900	13.96	51400	1.45	YFF	157	315M1-4	1680
125	10100	11.92	51400	1.60				

<b>P<sub>1</sub> = 160kW</b>								
------------------------------	--	--	--	--	--	--	--	--

88	17300	16.85	44800	1.05	YFA	157	315M2-4	1560
106	14400	13.96	46400	1.20	YFAF	157	315M2-4	1620
125	12300	11.92	47100	1.30	YF	157	315M2-4	1580
					YFF	157	315M2-4	1680

<b>P<sub>1</sub> = 200kW</b>								
------------------------------	--	--	--	--	--	--	--	--

88	21700	16.85	36100	0.85	YFA	157	315L1-4	1560
106	18000	13.96	39200	0.95	YFAF	157	315L1-4	1620
125	15300	11.92	41000	1.05	YF	157	315L1-4	1580
					YFF	157	315L1-4	1680



安装尺寸

Mounting Dimensions

YF37...

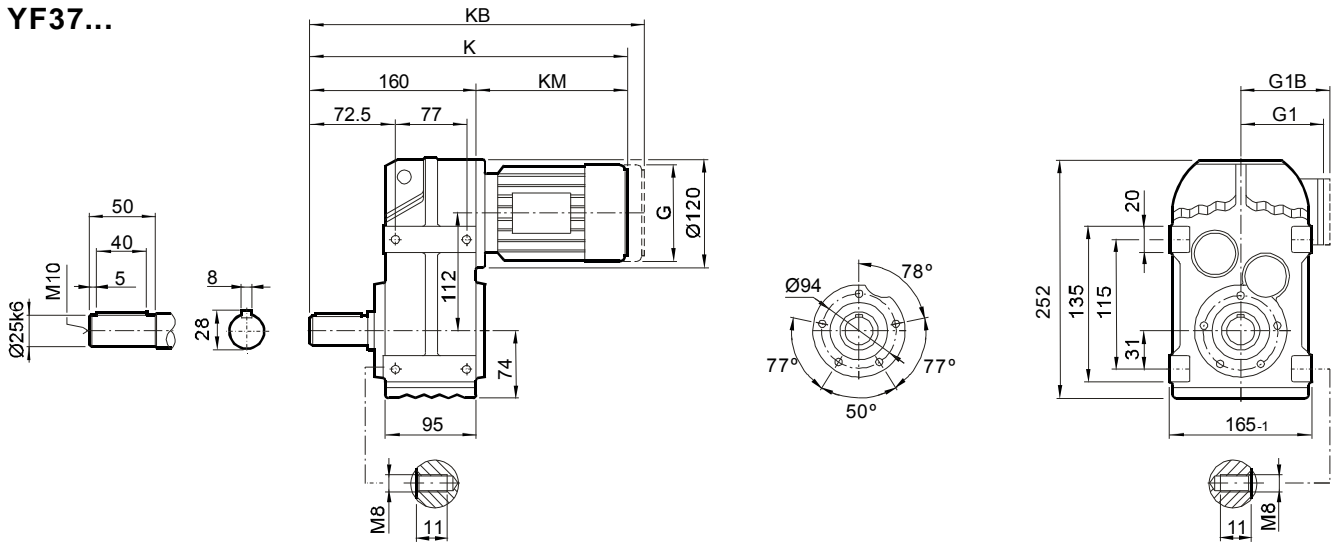

YFA37B...

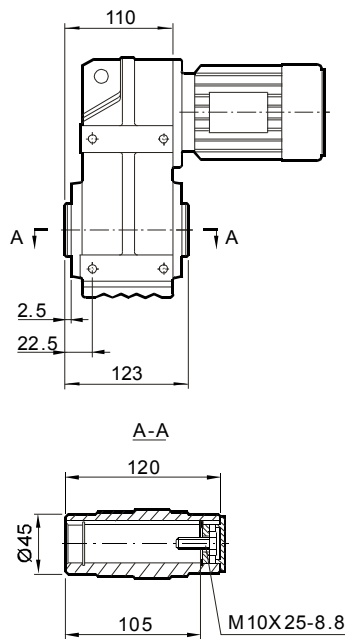

YFH37B...

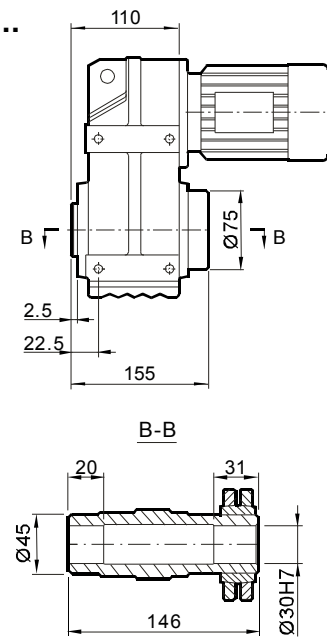

尺寸 Dimensions	电机规格 Motor frame									
	63	71	80	90	100M	100L				
G	132	145	145	197	197	197				
G1	99	122	122	154	166	166				
G1B	99	127	127	161	166	166				
K	351	366	416	436	488	518				
KB	406	430	480	521	573	603				
KM	191	206	256	276	328	358				

尺寸说明

以上尺寸为直联普通电机和制动电机尺寸；  
G1B,KB为制动电机尺寸,其余为普通电机尺寸；  
防爆电机, 辊道电机, 船用电机等须加过渡法兰, 见243页。

ATTENTION

Dimensions of general and brake motor shown in upon table,  
the others like explosion, roller, or marine motor coupled by  
adaptor, the dimensions on page 243.



安装尺寸

Mounting Dimensions

YFF37...

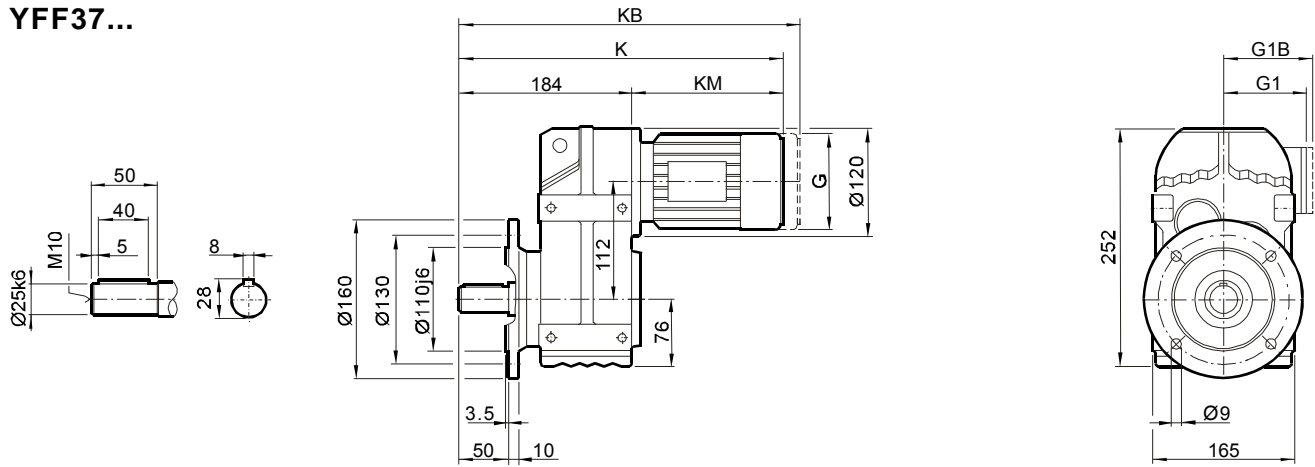

YFAF37...

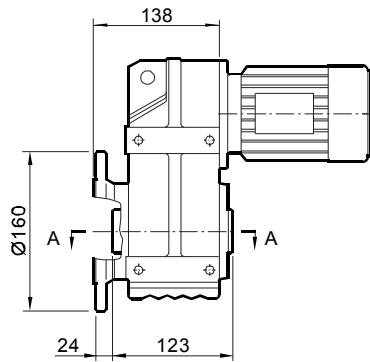

YFHF37...

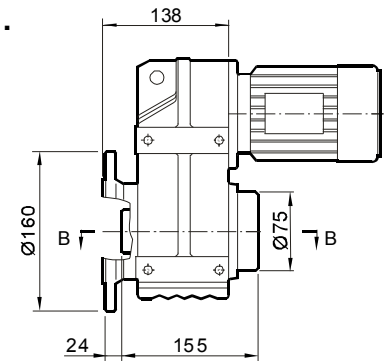

A-A

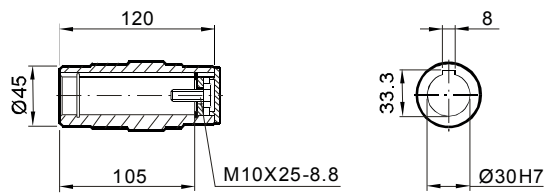

B-B

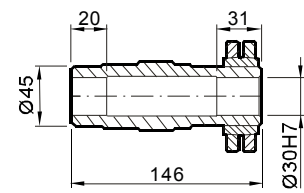

尺寸 Dimensions	电机规格 Motor frame									
	63	71	80	90	100M	100L				
G	132	145	145	197	197	197				
G1	99	122	122	154	166	166				
G1B	99	127	127	161	166	166				
K	375	390	440	460	512	542				
KB	430	454	504	545	597	627				
KM	191	206	256	276	328	358				

尺寸说明

以上尺寸为直联普通电机和制动电机尺寸；  
G1B,KB为制动电机尺寸,其余为普通电机尺寸；  
防爆电机, 辊道电机, 船用电机等须加过渡法兰, 见243页。

ATTENTION

Dimensions of general and brake motor shown in upon table, the others like explosion, roller, or marine motor coupled by adaptor, the dimensions on page 243.



安装尺寸

Mounting Dimensions

YFA37...

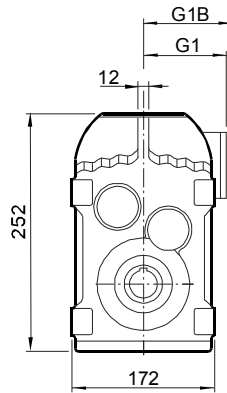
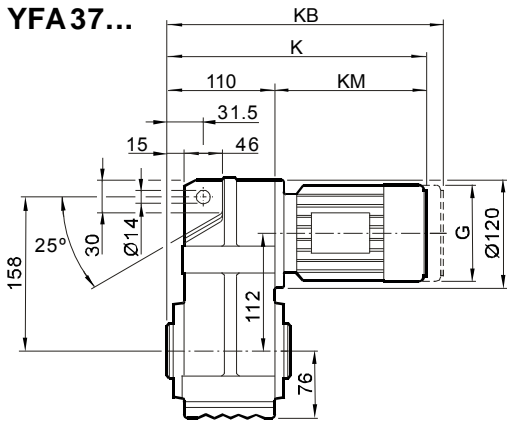

YF...37/G...

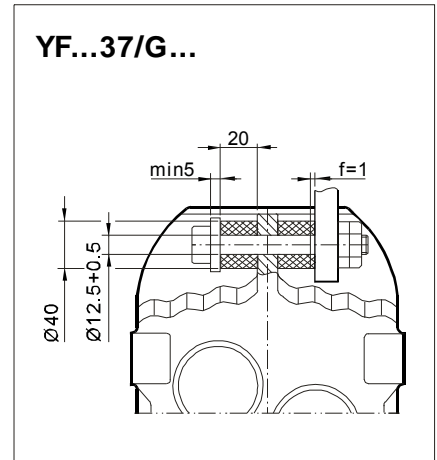

YFA37...

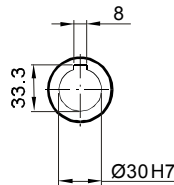
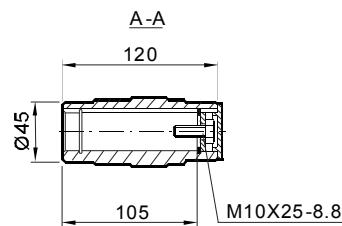
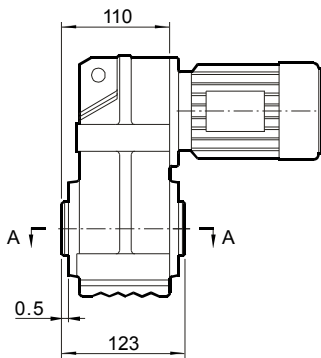

YFH37...

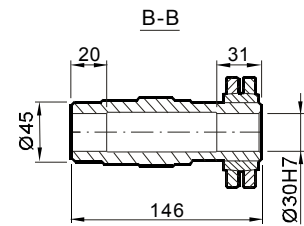
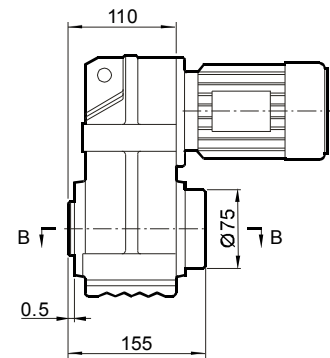

尺寸 Dimensions	电机规格 Motor frame										
	63	71	80	90	100M	100L					
G	132	145	145	197	197	197					
G1	99	122	122	154	166	166					
G1B	99	127	127	161	166	166					
K	301	316	366	386	438	468					
KB	356	380	430	471	523	553					
KM	191	206	256	276	328	358					

尺寸说明

以上尺寸为直联普通电机和制动电机尺寸；  
G1B,KB为制动电机尺寸,其余为普通电机尺寸；  
防爆电机, 辊道电机, 船用电机等须加过渡法兰, 见243页。

ATTENTION

Dimensions of general and brake motor shown in upon table, the others like explosion, roller, or marine motor coupled by adaptor, the dimensions on page 243.



安装尺寸

Mounting Dimensions

YFAZ37...

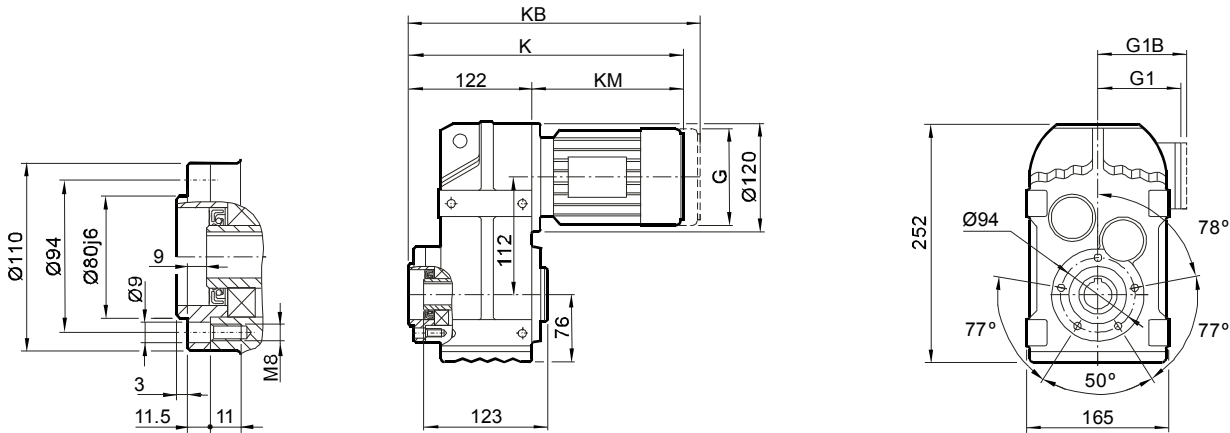

YFAZ37...

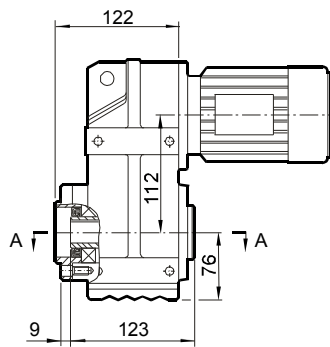

YFHZ37...

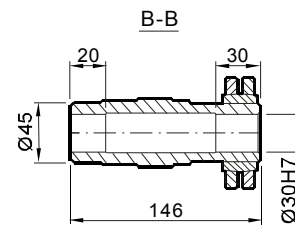
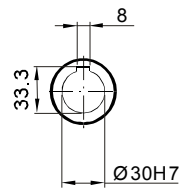
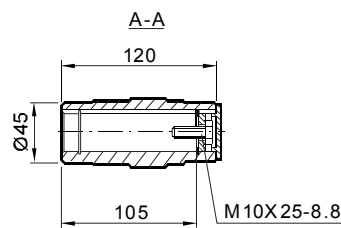
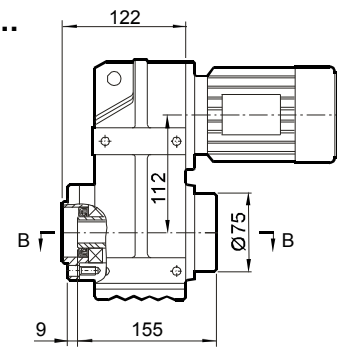

尺寸 Dimensions	电机规格 Motor frame									
	63	71	80	90	100M	100L				
G	132	145	145	197	197	197				
G1	99	122	122	154	166	166				
G1B	99	127	127	161	166	166				
K	313	328	378	398	450	480				
KB	368	392	442	483	535	565				
KM	191	206	256	276	328	358				

尺寸说明

以上尺寸为直联普通电机和制动电机尺寸；  
G1B,KB为制动电机尺寸,其余为普通电机尺寸；  
防爆电机, 辊道电机, 船用电机等须加过渡法兰, 见243页。

ATTENTION

Dimensions of general and brake motor shown in upon table, the others like explosion, roller, or marine motor coupled by adaptor, the dimensions on page 243.



安装尺寸

Mounting Dimensions

YF47...

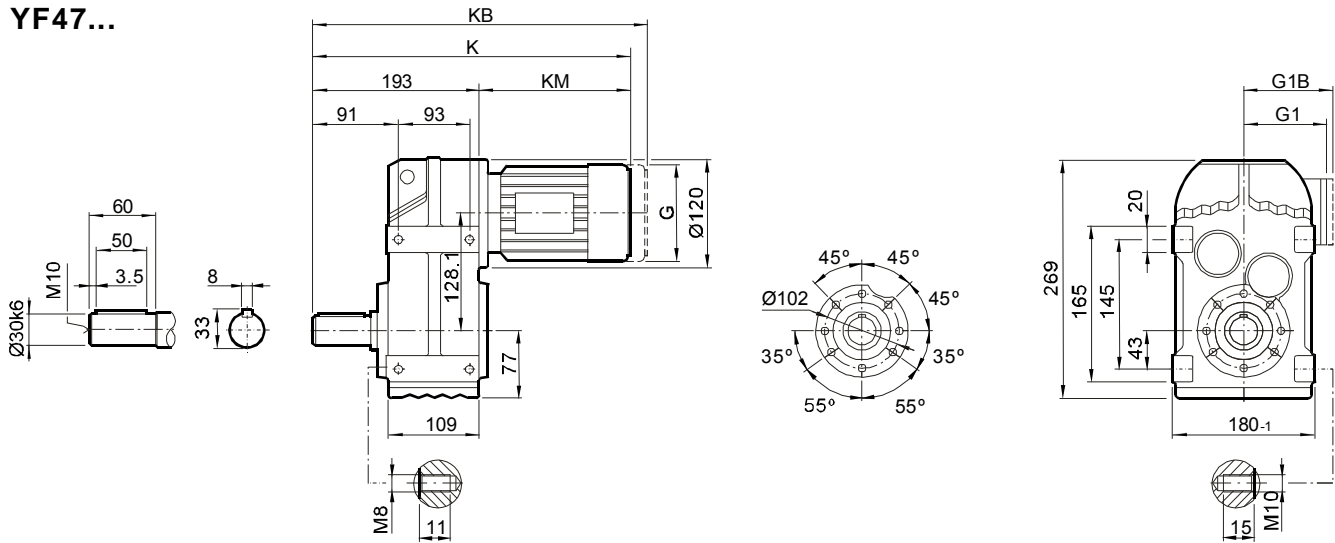

YFA47B...

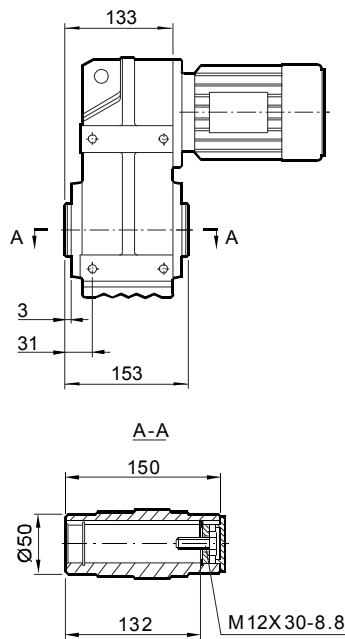

YFH47B...

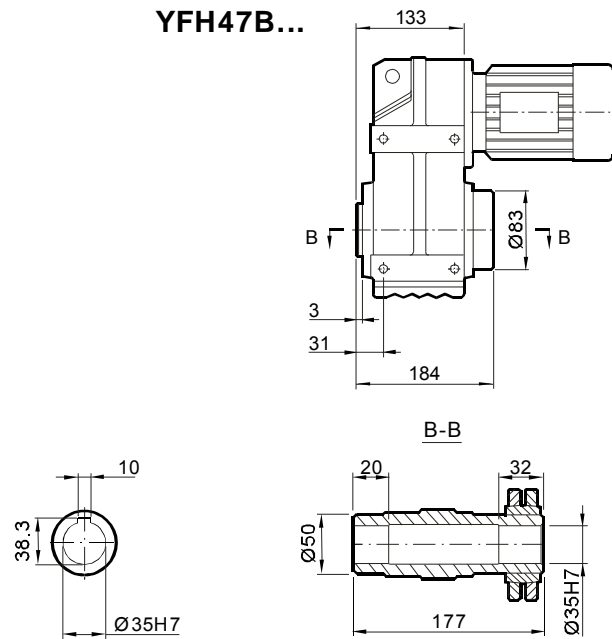

尺寸 Dimensions	电机规格 Motor frame									
	63	71	80	90	100M	100L				
G	132	145	145	197	197	197				
G1	105	122	122	154	166	166				
G1B	105	127	127	161	166	166				
K	384	399	449	469	521	551				
KB	439	462	512	554	606	636				
KM	191	206	256	276	328	358				

尺寸说明

以上尺寸为直联普通电机和制动电机尺寸；  
G1B,KB为制动电机尺寸,其余为普通电机尺寸；  
防爆电机, 辊道电机, 船用电机等须加过渡法兰, 见243页。

ATTENTION

Dimensions of general and brake motor shown in upon table,  
the others like explosion, roller, or marine motor coupled by  
adaptor, the dimensions on page 243.



安装尺寸

Mounting Dimensions

YFF47...

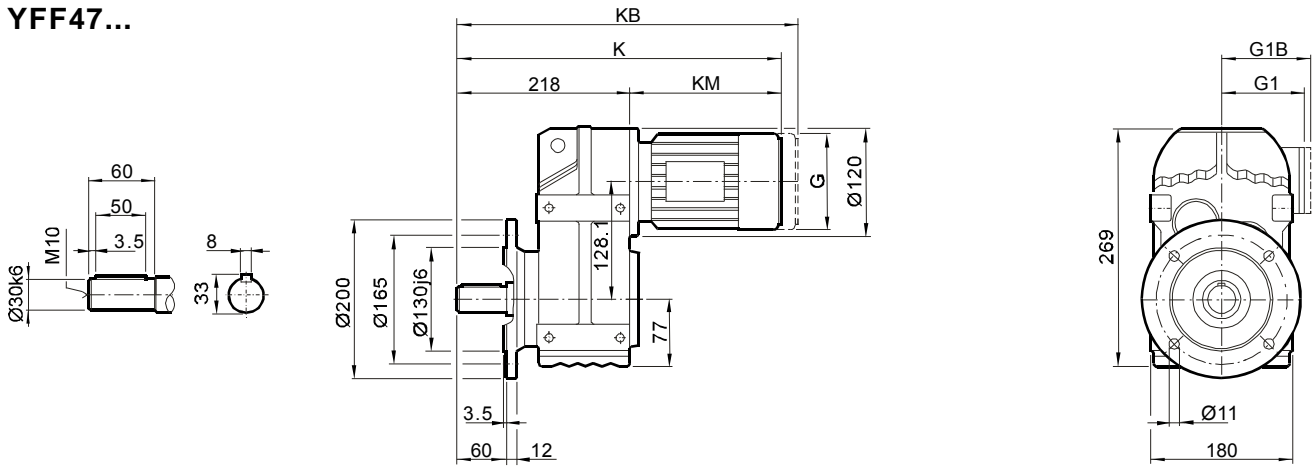

YFAF47...

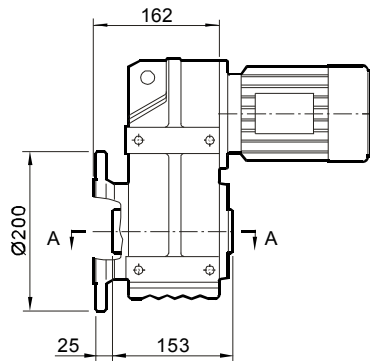

YFHF47...

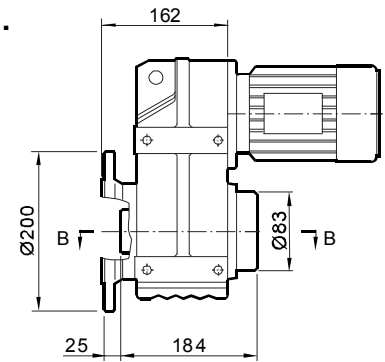

A-A

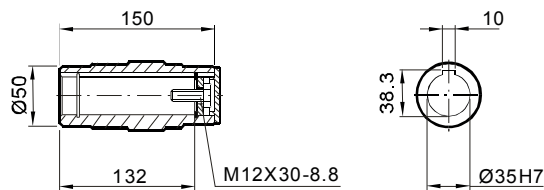

B-B

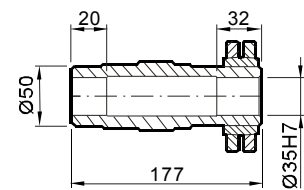

尺寸 Dimensions	电机规格 Motor frame									
	63	71	80	90	100M	100L				
G	132	145	145	197	197	197				
G1	105	122	122	154	166	166				
G1B	105	127	127	161	166	166				
K	409	424	474	494	546	576				
KB	464	487	537	579	631	661				
KM	191	206	256	276	328	358				

尺寸说明

以上尺寸为直联普通电机和制动电机尺寸；  
G1B,KB为制动电机尺寸,其余为普通电机尺寸；  
防爆电机, 辊道电机, 船用电机等须加过渡法兰, 见243页。

ATTENTION

Dimensions of general and brake motor shown in upon table, the others like explosion, roller, or marine motor coupled by adaptor, the dimensions on page 243.



安装尺寸

Mounting Dimensions

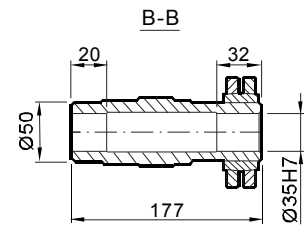
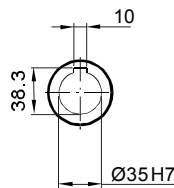
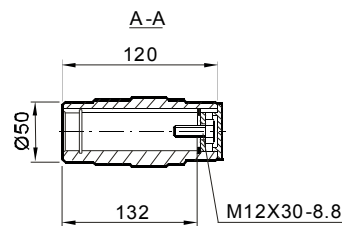
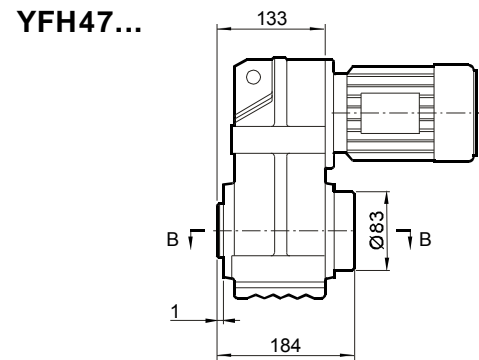
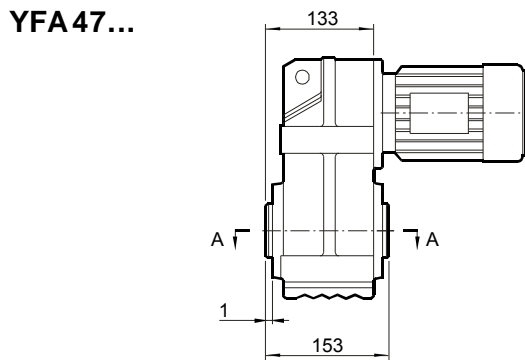
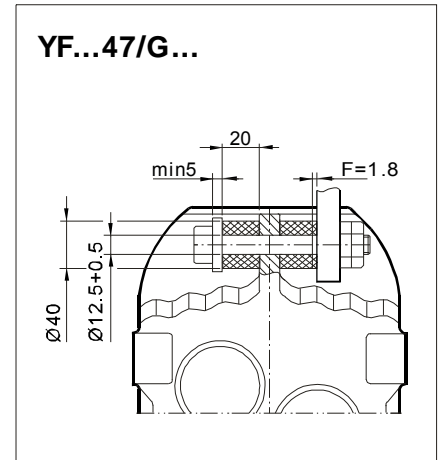
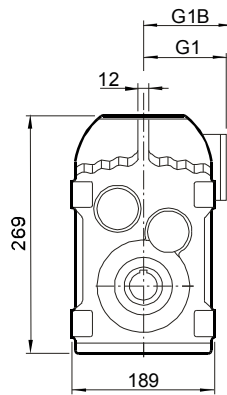
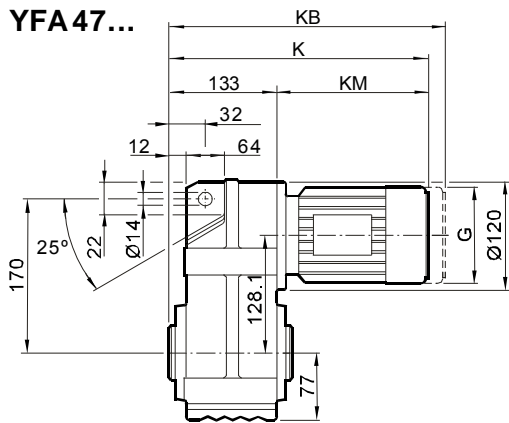

尺寸 Dimensions	电机规格 Motor frame										
	63	71	80	90	100M	100L					
G	132	145	145	197	197	197					
G1	105	122	122	154	166	166					
G1B	105	127	127	161	166	166					
K	324	339	389	409	461	491					
KB	379	402	452	494	546	576					
KM	191	206	256	276	328	358					

尺寸说明

以上尺寸为直联普通电机和制动电机尺寸；  
G1B,KB为制动电机尺寸,其余为普通电机尺寸；  
防爆电机, 辊道电机, 船用电机等须加过渡法兰, 见243页。

ATTENTION

Dimensions of general and brake motor shown in upon table, the others like explosion, roller, or marine motor coupled by adaptor, the dimensions on page 243.



安装尺寸

Mounting Dimensions

YFAZ47...

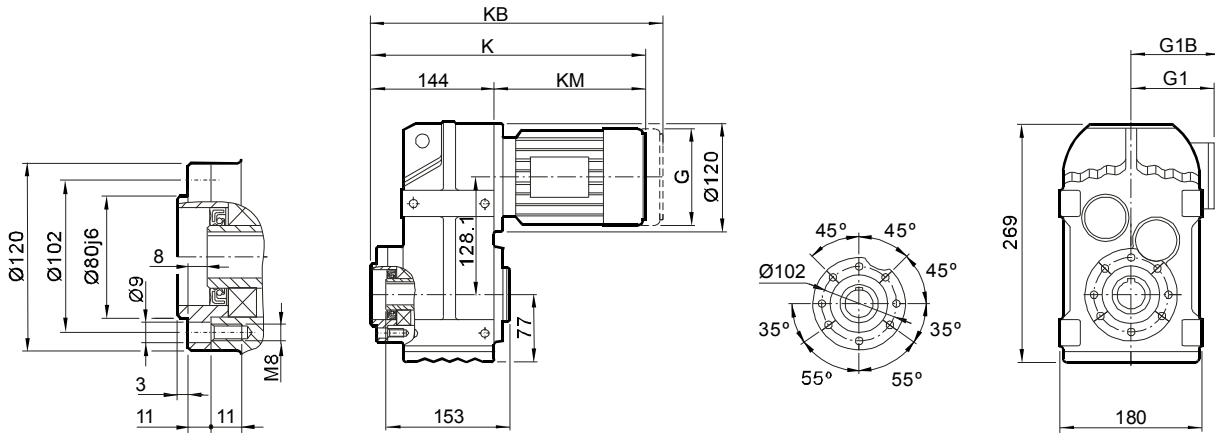

YFAZ47...

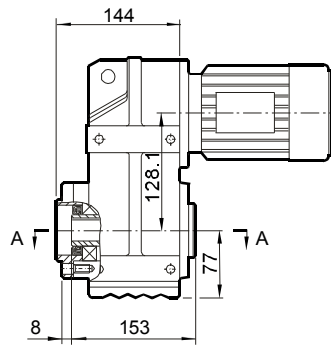

YFHZ47...

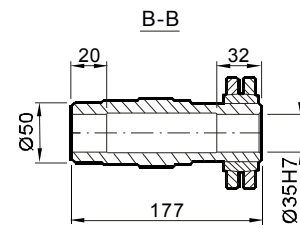
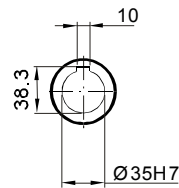
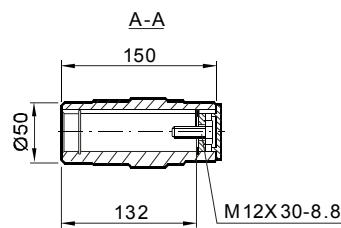
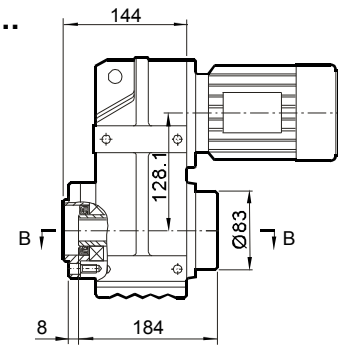

尺寸 Dimensions	电机规格 Motor frame									
	63	71	80	90	100M	100L				
G	132	145	145	197	197	197				
G1	105	122	122	154	166	166				
G1B	105	127	127	161	166	166				
K	335	350	400	420	472	502				
KB	390	413	463	505	557	587				
KM	191	206	256	276	328	358				

尺寸说明

以上尺寸为直联普通电机和制动电机尺寸；  
G1B,KB为制动电机尺寸,其余为普通电机尺寸；  
防爆电机, 辊道电机, 船用电机等须加过渡法兰, 见243页。

ATTENTION

Dimensions of general and brake motor shown in upon table,  
the others like explosion, roller, or marine motor coupled by  
adaptor, the dimensions on page 243.



安装尺寸

Mounting Dimensions

YF57...

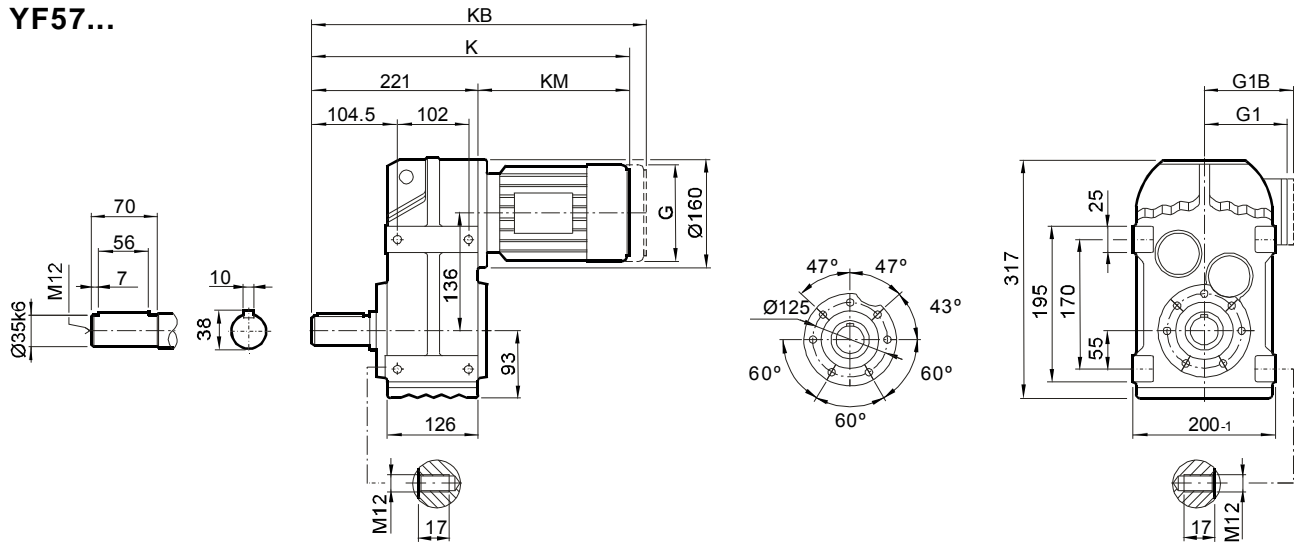

YFA57B...

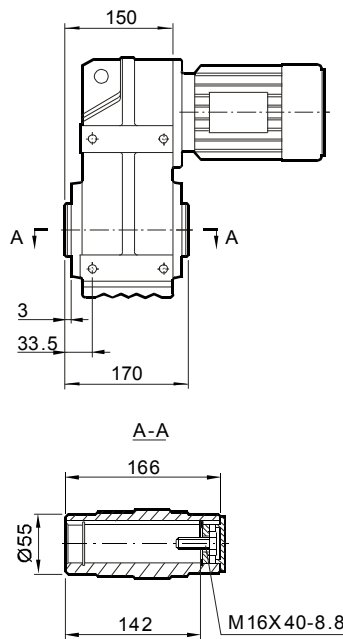

YFH57B...

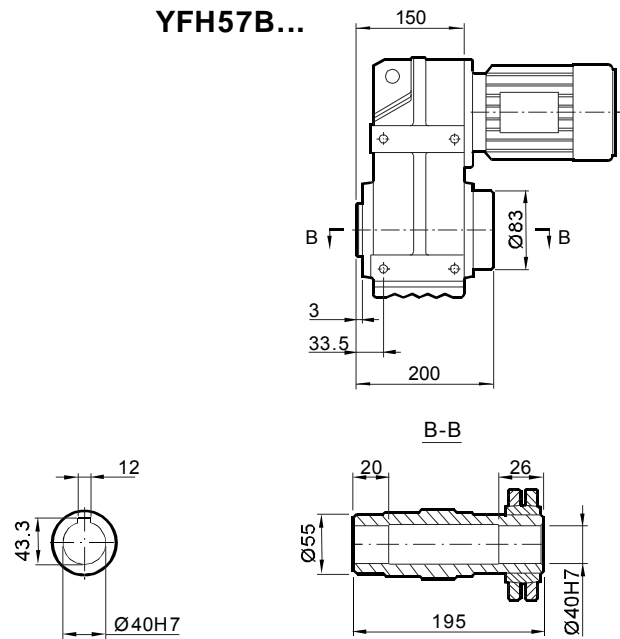

尺寸 Dimensions	电机规格 Motor frame										
	63	71	80	90	100M	100L	112M	132S			
G	132	145	145	197	197	197	221	221			
G1	105	122	122	154	166	166	179	179			
G1B	105	127	127	161	166	166	182	182			
K	406	420	470	490	540	570	575	623			
KB	461	484	534	575	625	655	655	703			
KM	185	199	249	269	319	349	354	402			

尺寸说明

以上尺寸为直联普通电机和制动电机尺寸；  
G1B,KB为制动电机尺寸,其余为普通电机尺寸；  
防爆电机, 辊道电机, 船用电机等须加过渡法兰, 见243页。

ATTENTION

Dimensions of general and brake motor shown in upon table,  
the others like explosion, roller, or marine motor coupled by  
adaptor, the dimensions on page 243.



安装尺寸

Mounting Dimensions

YFF57...

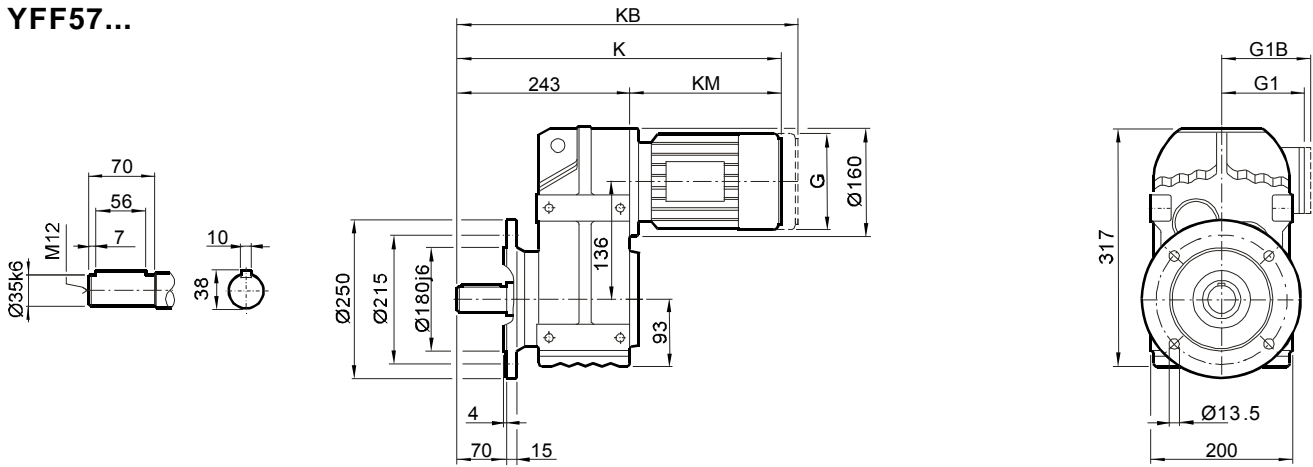

YFAF57...

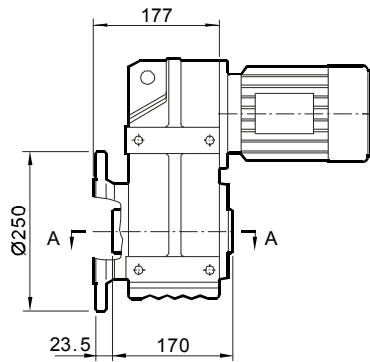

YFHF57...

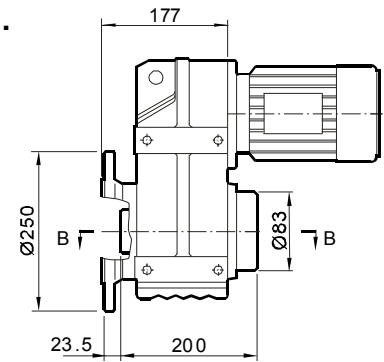

A-A

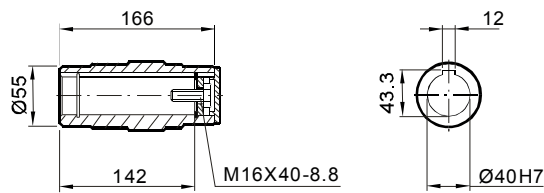

B-B

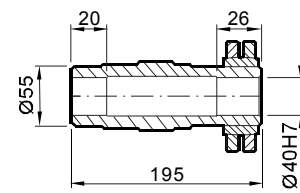

尺寸 Dimensions	电机规格 Motor frame							
	63	71	80	90	100M	100L	112M	132S
G	132	145	145	197	197	197	221	221
G1	105	122	122	154	166	166	179	179
G1B	105	127	127	161	166	166	182	182
K	428	442	492	512	562	592	597	645
KB	483	506	556	597	647	677	677	725
KM	185	199	249	269	319	349	354	402

尺寸说明

以上尺寸为直联普通电机和制动电机尺寸；  
G1B,KB为制动电机尺寸,其余为普通电机尺寸；  
防爆电机, 辊道电机, 船用电机等须加过渡法兰, 见243页。

ATTENTION

Dimensions of general and brake motor shown in upon table, the others like explosion, roller, or marine motor coupled by adaptor, the dimensions on page 243.



安装尺寸

Mounting Dimensions

YFA57...

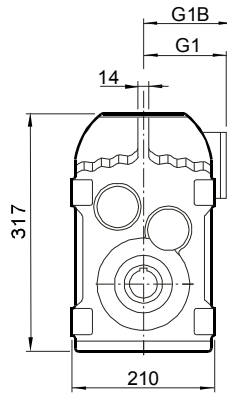
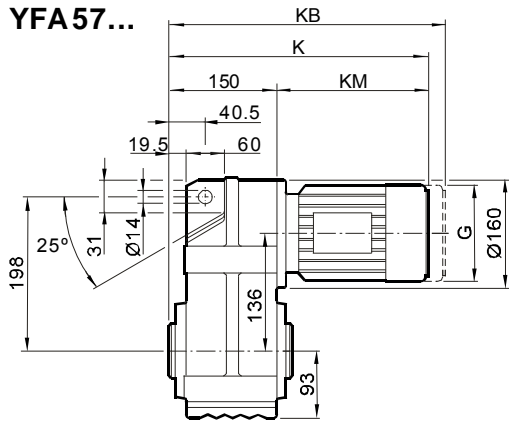

YF...57/G...

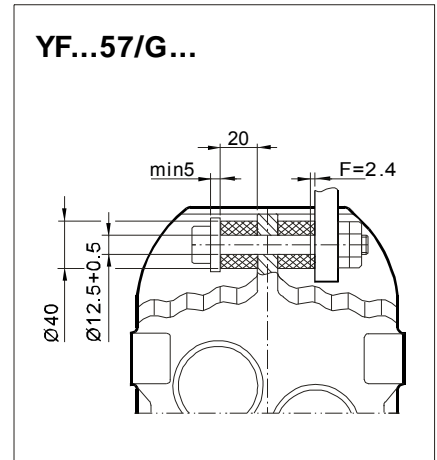

YFA57...

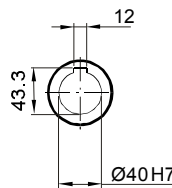
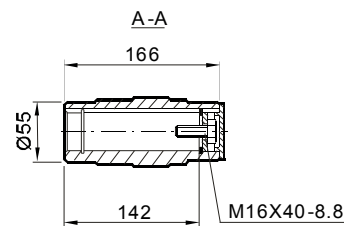
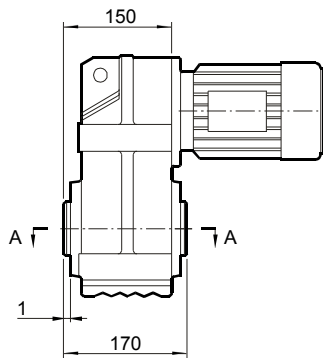

YFH57...

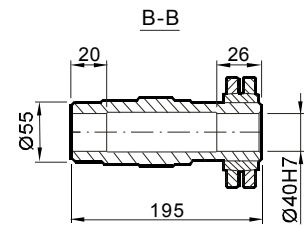
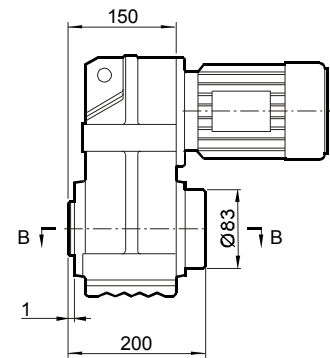

尺寸 Dimensions	电机规格 Motor frame							
	63	71	80	90	100M	100L	112M	132S
G	132	145	145	197	197	197	221	221
G1	105	122	122	154	166	166	179	179
G1B	105	127	127	161	166	166	182	182
K	335	349	399	419	469	499	504	552
KB	390	413	463	504	554	584	584	632
KM	185	199	249	269	319	349	354	402

尺寸说明

以上尺寸为直联普通电机和制动电机尺寸；  
G1B,KB为制动电机尺寸,其余为普通电机尺寸；  
防爆电机, 辊道电机, 船用电机等须加过渡法兰, 见243页。

ATTENTION

Dimensions of general and brake motor shown in upon table, the others like explosion, roller, or marine motor coupled by adaptor, the dimensions on page 243.



安装尺寸

Mounting Dimensions

YFAZ57...

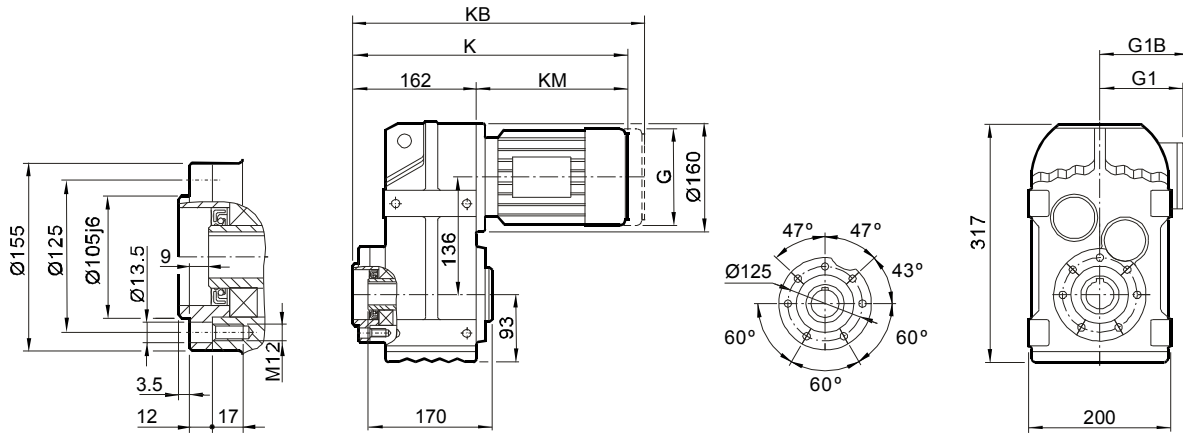

YFAZ57...

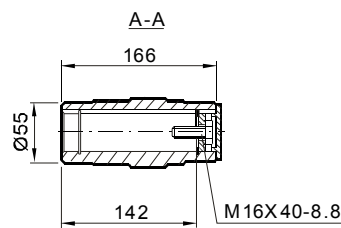
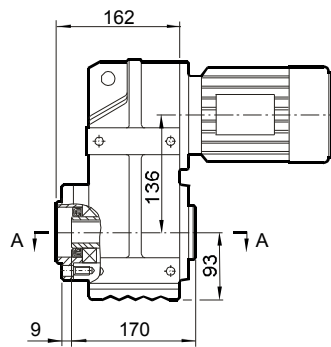

YFHZ57...

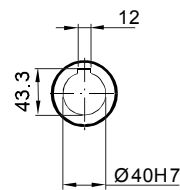
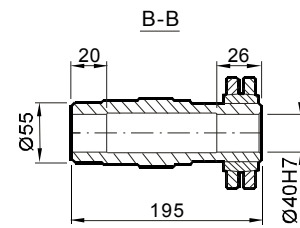
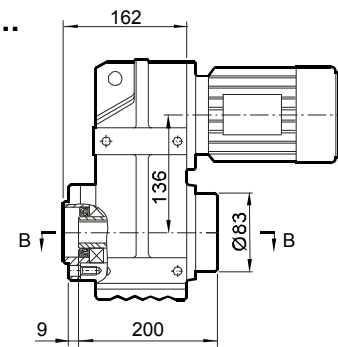

尺寸 Dimensions	电机规格 Motor frame							
	63	71	80	90	100M	100L	112M	132S
G	132	145	145	197	197	197	221	221
G1	105	122	122	154	166	166	179	179
G1B	105	127	127	161	166	166	182	182
K	347	361	411	431	481	511	516	564
KB	402	425	475	516	566	596	596	644
KM	185	199	249	269	319	349	354	402

尺寸说明

以上尺寸为直联普通电机和制动电机尺寸；  
G1B,KB为制动电机尺寸,其余为普通电机尺寸；  
防爆电机, 辊道电机, 船用电机等须加过渡法兰, 见243页。

ATTENTION

Dimensions of general and brake motor shown in upon table, the others like explosion, roller, or marine motor coupled by adaptor, the dimensions on page 243.



安装尺寸

Mounting Dimensions

YF67...

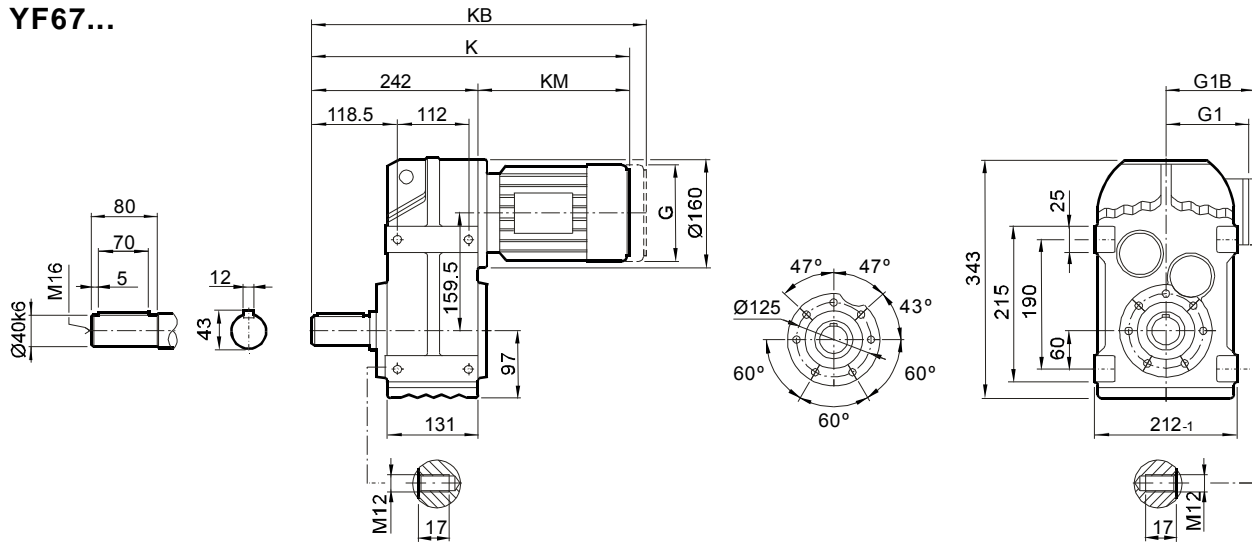

YFA67B...

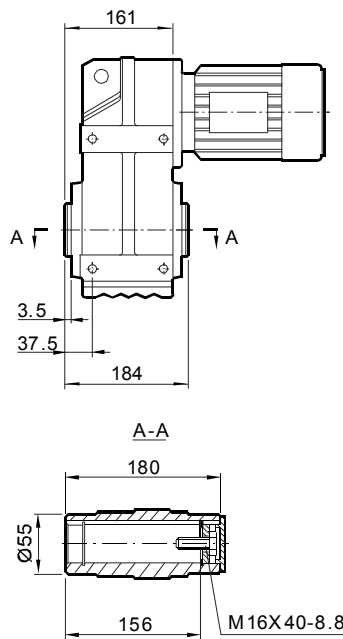

YFH67B...

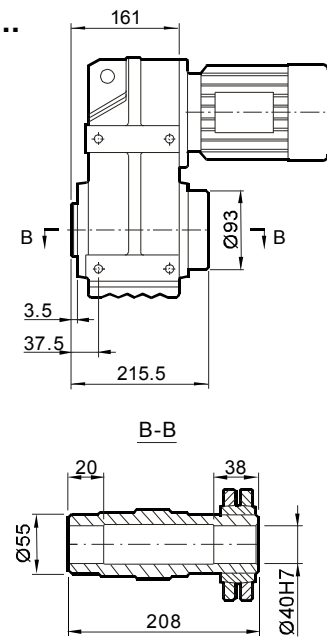

尺寸 Dimensions	电机规格 Motor frame							
	63	71	80	90	100M	100L	112M	132S
G	132	145	145	197	197	197	221	221
G1	105	122	122	154	166	166	179	179
G1B	105	127	127	161	166	166	182	182
K	427	441	491	511	561	591	596	644
KB	482	505	555	596	646	676	676	724
KM	185	199	249	269	319	349	354	402

尺寸说明

以上尺寸为直联普通电机和制动电机尺寸；  
G1B,KB为制动电机尺寸,其余为普通电机尺寸；  
防爆电机, 辊道电机, 船用电机等须加过渡法兰, 见243页。

ATTENTION

Dimensions of general and brake motor shown in upon table,  
the others like explosion, roller, or marine motor coupled by  
adaptor, the dimensions on page 243.



安装尺寸

Mounting Dimensions

YFF67...

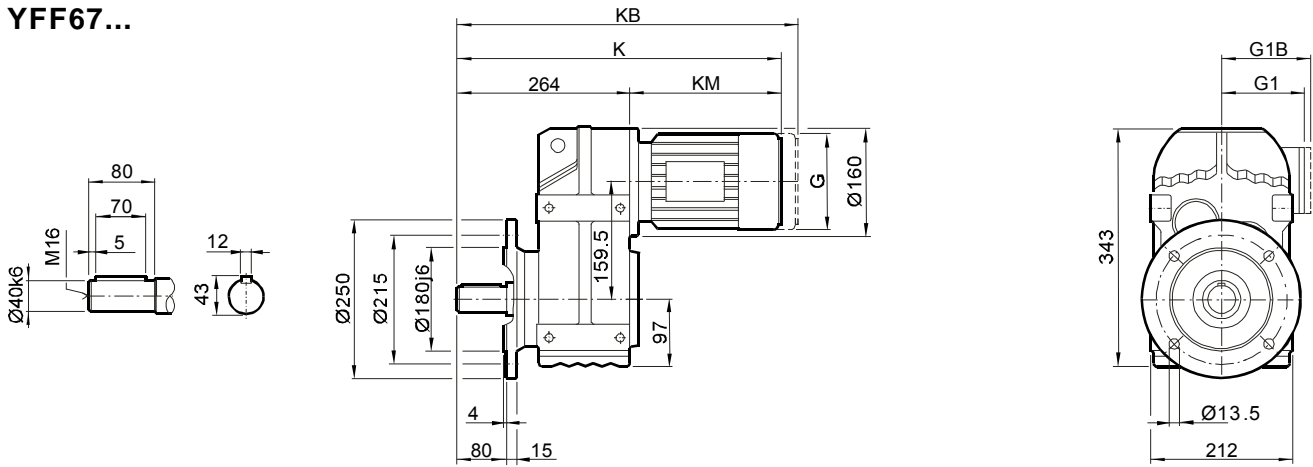

YFAF67...

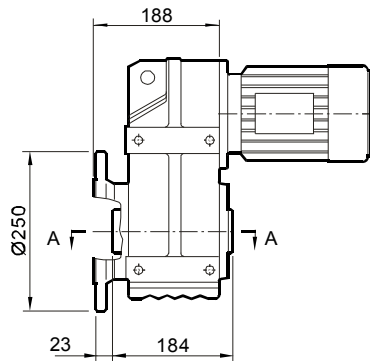

YFHF67...

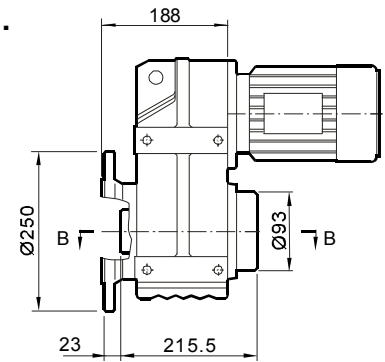

A-A

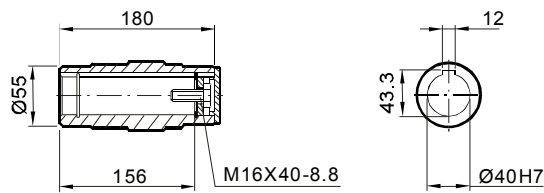

B-B

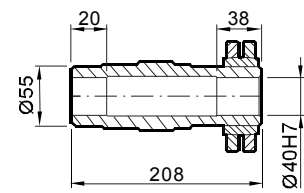

尺寸 Dimensions	电机规格 Motor frame							
	63	71	80	90	100M	100L	112M	132S
G	132	145	145	197	197	197	221	221
G1	105	122	122	154	166	166	179	179
G1B	105	127	127	161	166	166	182	182
K	449	463	513	533	583	613	618	666
KB	504	527	577	618	668	698	698	746
KM	185	199	249	269	319	349	354	402

尺寸说明

以上尺寸为直联普通电机和制动电机尺寸；  
G1B,KB为制动电机尺寸,其余为普通电机尺寸；  
防爆电机, 辊道电机, 船用电机等须加过渡法兰, 见243页。

ATTENTION

Dimensions of general and brake motor shown in upon table, the others like explosion, roller, or marine motor coupled by adaptor, the dimensions on page 243.



安装尺寸

Mounting Dimensions

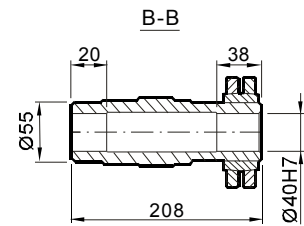
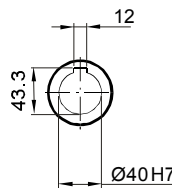
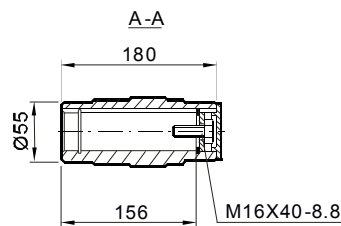
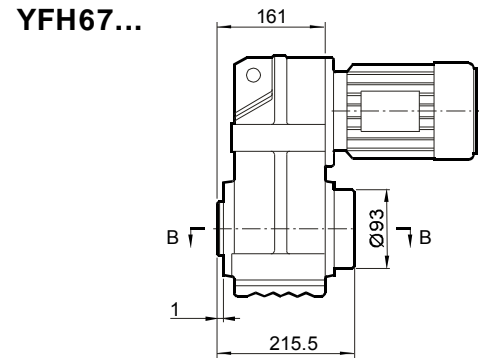
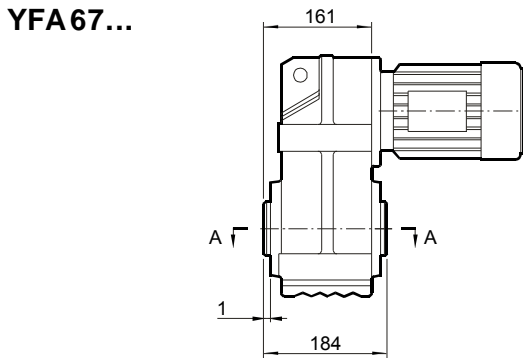
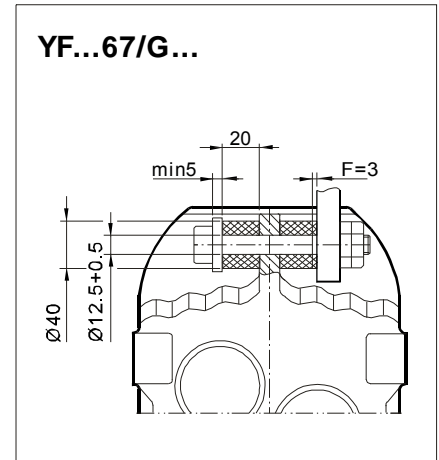
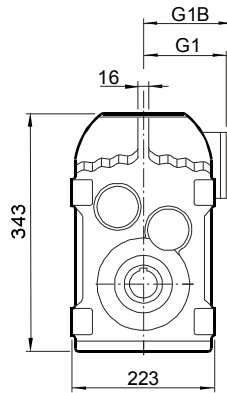
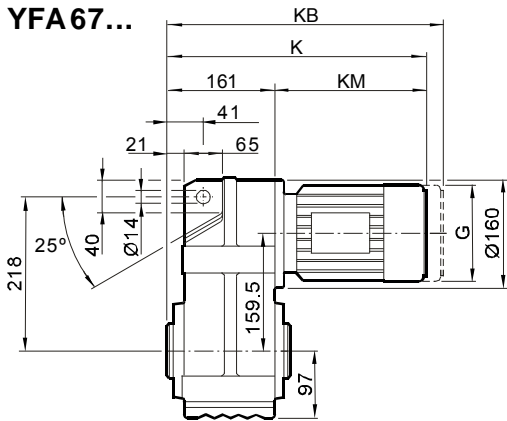

尺寸 Dimensions	电机规格 Motor frame							
	63	71	80	90	100M	100L	112M	132S
G	132	145	145	197	197	197	221	221
G1	105	122	122	154	166	166	179	179
G1B	105	127	127	161	166	166	182	182
K	346	360	410	430	480	510	515	563
KB	401	424	474	515	565	595	595	643
KM	185	199	249	269	319	349	354	402

尺寸说明

以上尺寸为直联普通电机和制动电机尺寸；  
G1B,KB为制动电机尺寸,其余为普通电机尺寸；  
防爆电机, 辊道电机, 船用电机等须加过渡法兰, 见243页。

ATTENTION

Dimensions of general and brake motor shown in upon table,  
the others like explosion, roller, or marine motor coupled by  
adaptor, the dimensions on page 243.



安装尺寸

Mounting Dimensions

YFAZ67...

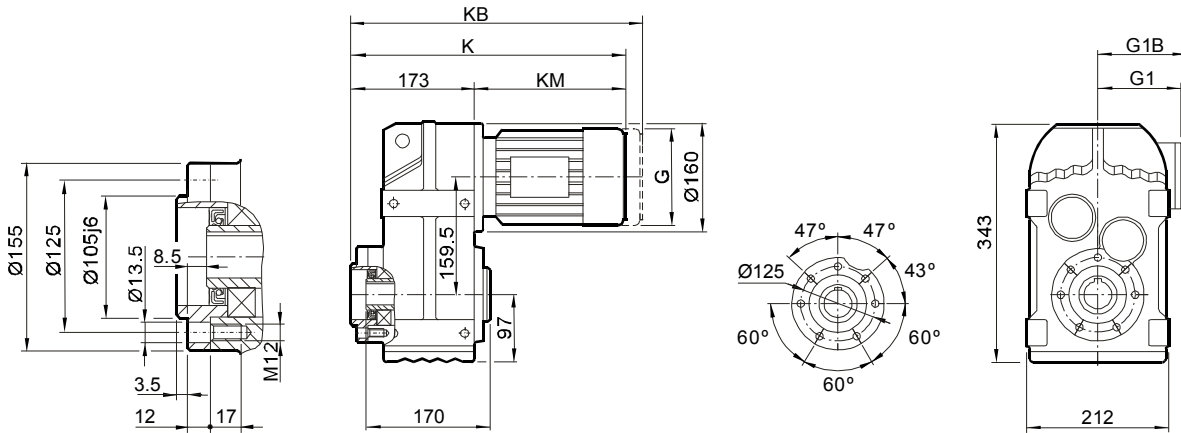

YFAZ67...

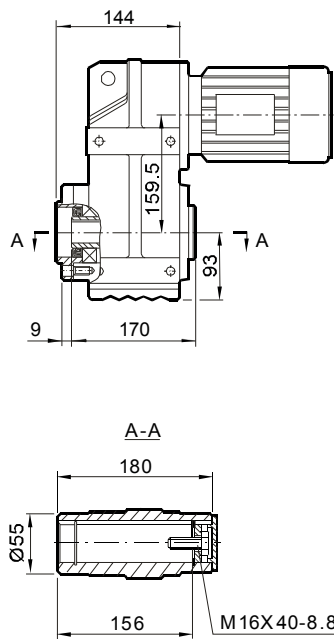

YFHZ67...

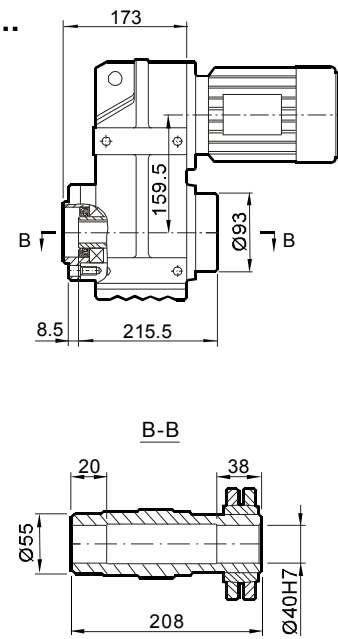

尺寸 Dimensions	电机规格 Motor frame								
	63	71	80	90	100M	100L	112M	132S	
G	132	145	145	197	197	197	221	221	
G1	105	122	122	154	166	166	179	179	
G1B	105	127	127	161	166	166	182	182	
K	358	372	422	442	492	522	527	575	
KB	413	436	486	527	577	607	607	655	
KM	185	199	249	269	319	349	354	402	

尺寸说明

以上尺寸为直联普通电机和制动电机尺寸；  
G1B,KB为制动电机尺寸,其余为普通电机尺寸；  
防爆电机, 辊道电机, 船用电机等须加过渡法兰, 见243页。

ATTENTION

Dimensions of general and brake motor shown in upon table,  
the others like explosion, roller, or marine motor coupled by  
adaptor, the dimensions on page 243.



安装尺寸

Mounting Dimensions

**YF77...**

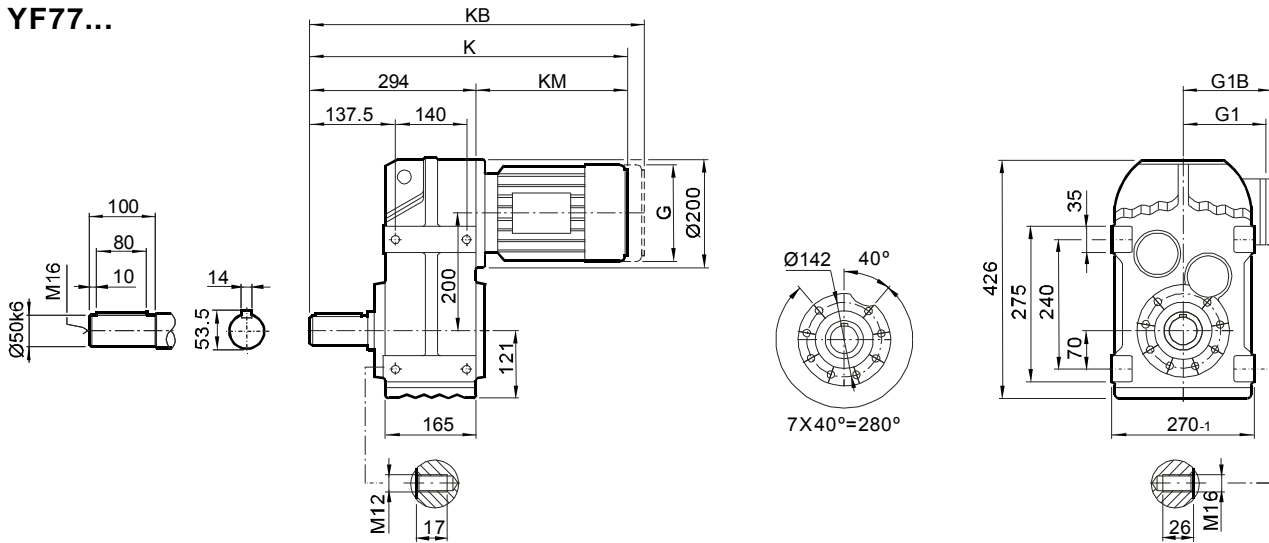

**YFA77B...**

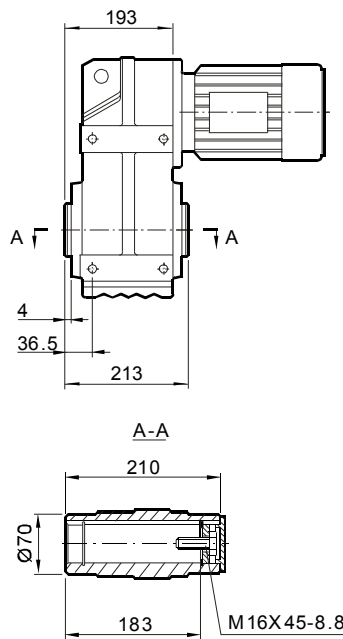

**YFH77B...**

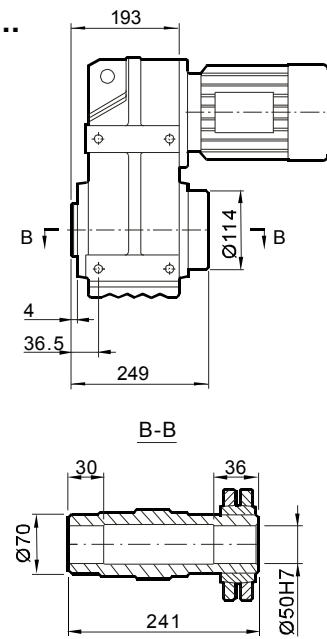

尺寸 Dimensions	电机规格 Motor frame									
	63	71	80	90	100M	100L	112M	132S	132M	160M
<b>G</b>	132	145	145	197	197	197	221	221	275	275
<b>G1</b>	105	122	122	154	166	166	179	179	230	230
<b>G1B</b>	105	127	127	161	166	166	182	182	230	230
<b>K</b>	473	487	537	555	605	635	639	684	706	766
<b>KB</b>	528	551	601	640	690	720	719	764	818	878
<b>KM</b>	179	193	243	261	311	341	345	390	412	472

尺寸说明

以上尺寸为直联普通电机和制动电机尺寸；  
G1B,KB为制动电机尺寸,其余为普通电机尺寸；  
防爆电机, 辊道电机, 船用电机等须加过渡法兰, 见243页。

**ATTENTION**

Dimensions of general and brake motor shown in upon table,  
the others like explosion, roller, or marine motor coupled by  
adaptor, the dimensions on page 243.



安装尺寸

Mounting Dimensions

YFF77...

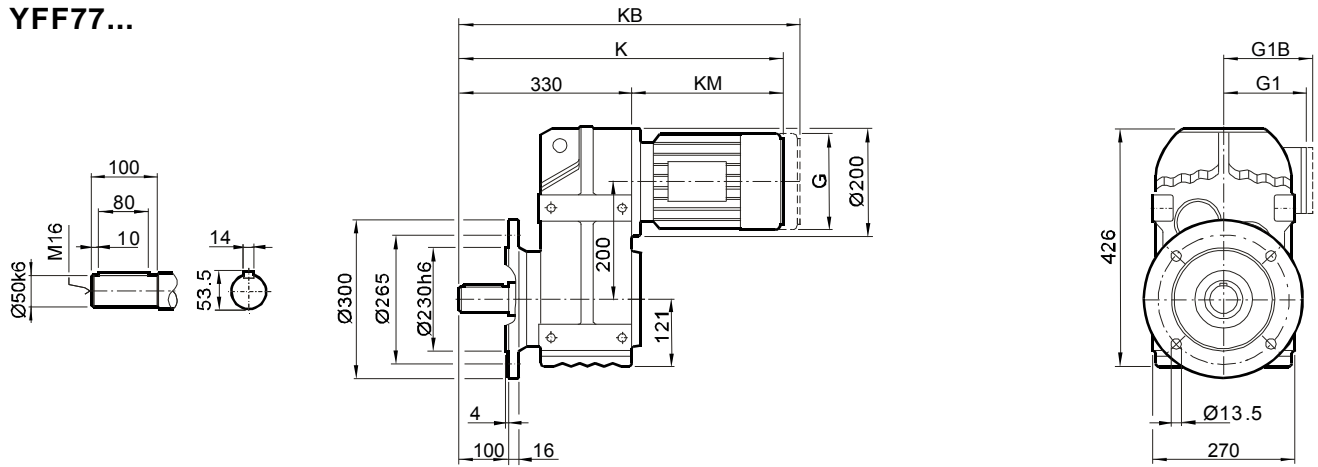

YFAF77...

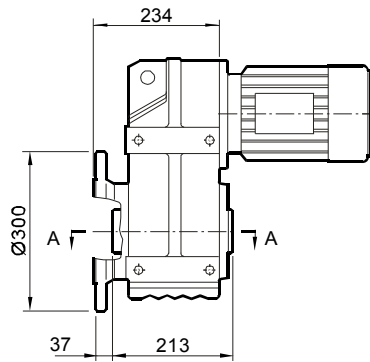

YFHF77...

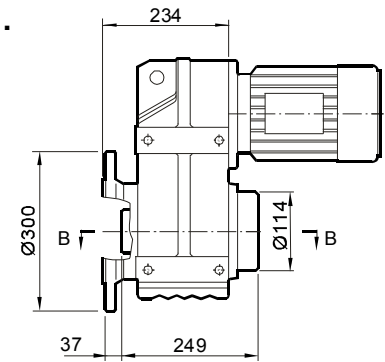

A-A

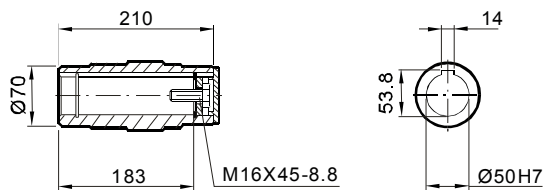

B-B

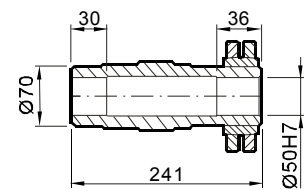

尺寸 Dimensions	电机规格 Motor frame									
	63	71	80	90	100M	100L	112M	132S	132M	160M
G	132	145	145	197	197	197	221	221	275	275
G1	105	122	122	154	166	166	179	179	230	230
G1B	105	127	127	161	166	166	182	182	230	230
K	509	523	573	591	641	671	675	720	742	802
KB	564	587	637	676	726	756	755	800	854	914
KM	179	193	243	261	311	341	345	390	412	472

尺寸说明

以上尺寸为直联普通电机和制动电机尺寸；  
G1B,KB为制动电机尺寸,其余为普通电机尺寸；  
防爆电机, 辊道电机, 船用电机等须加过渡法兰, 见243页。

ATTENTION

Dimensions of general and brake motor shown in upon table, the others like explosion, roller, or marine motor coupled by adaptor, the dimensions on page 243.



安装尺寸

Mounting Dimensions

YFA77...

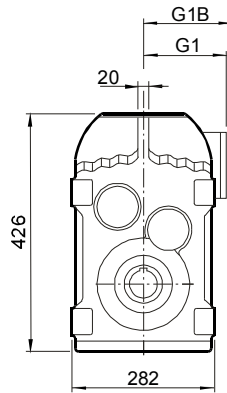
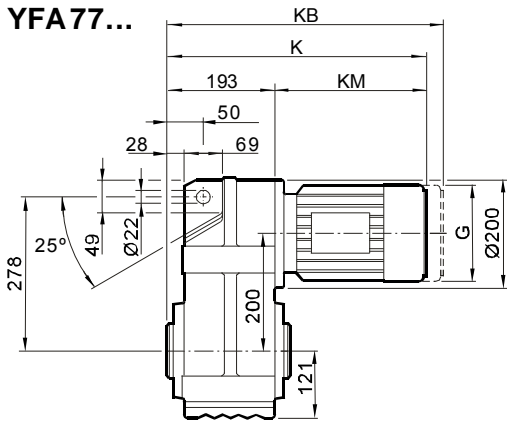

YF...77/G...

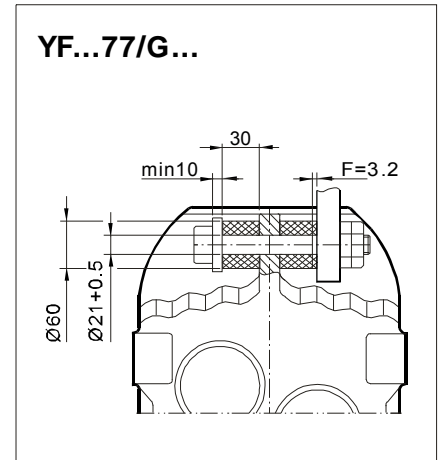

YFA77...

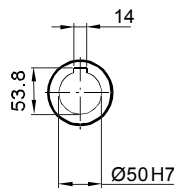
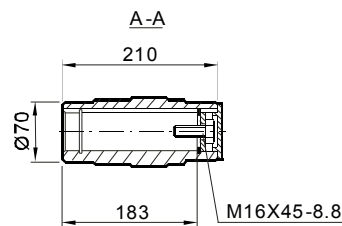
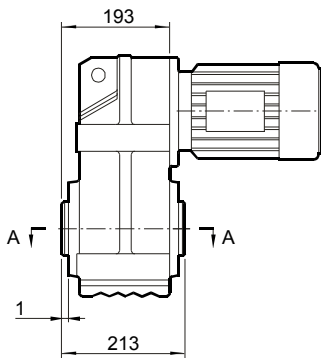

YFH77...

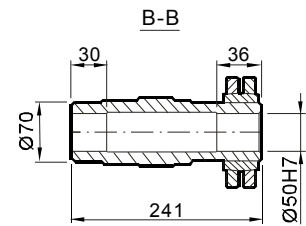
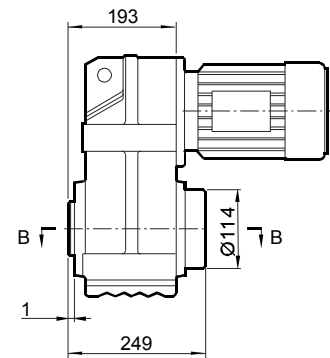

尺寸 Dimensions	电机规格 Motor frame									
	63	71	80	90	100M	100L	112M	132S	132M	160M
G	132	145	145	197	197	197	221	221	275	275
G1	105	122	122	154	166	166	179	179	230	230
G1B	105	127	127	161	166	166	182	182	230	230
K	372	386	436	454	504	534	538	583	605	665
KB	427	450	500	539	589	619	618	663	717	777
KM	179	193	243	261	311	341	345	390	412	472

尺寸说明

以上尺寸为直联普通电机和制动电机尺寸；  
G1B,KB为制动电机尺寸,其余为普通电机尺寸；  
防爆电机, 辊道电机, 船用电机等须加过渡法兰, 见243页。

ATTENTION

Dimensions of general and brake motor shown in upon table, the others like explosion, roller, or marine motor coupled by adaptor, the dimensions on page 243.



安装尺寸

Mounting Dimensions

YFAZ77...

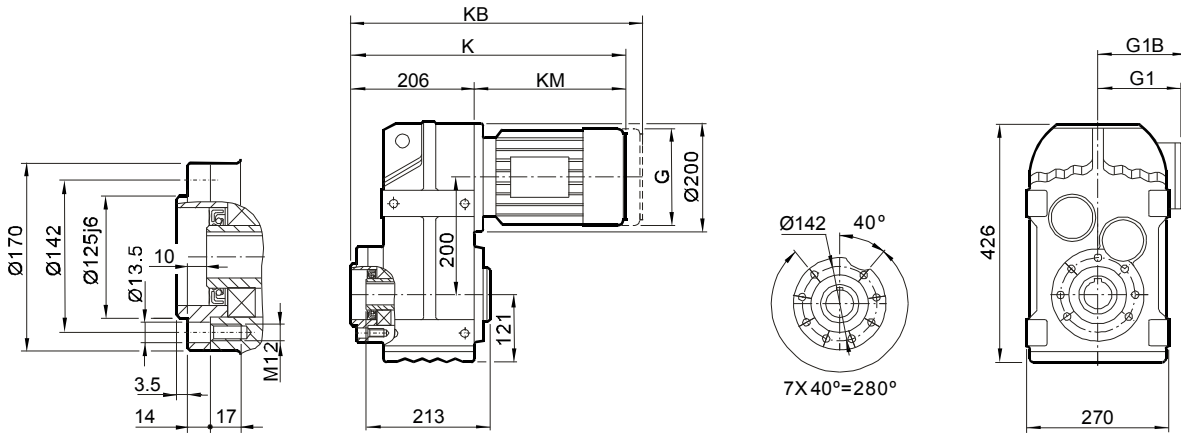

YFAZ77...

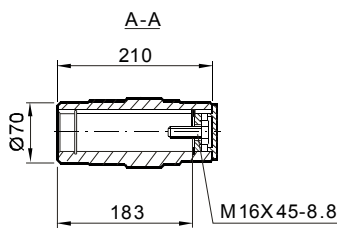
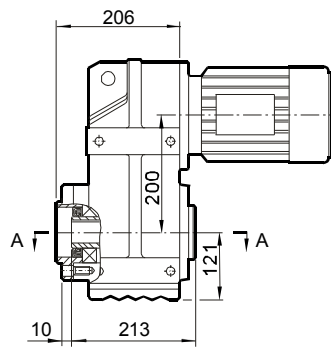

YFHZ77...

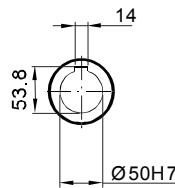
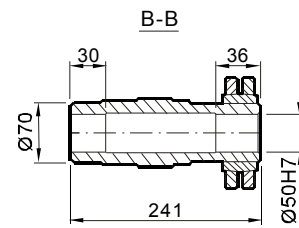
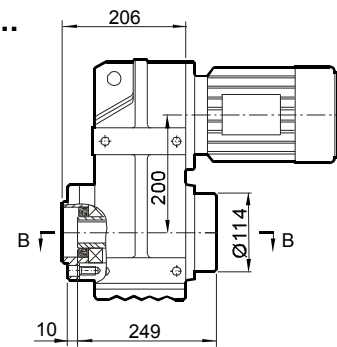

尺寸 Dimensions	电机规格 Motor frame									
	63	71	80	90	100M	100L	112M	132S	132M	160M
G	132	145	145	197	197	197	221	221	275	275
G1	105	122	122	154	166	166	179	179	230	230
G1B	105	127	127	161	166	166	182	182	230	230
K	385	399	449	467	517	547	551	596	618	678
KB	440	463	513	552	602	632	631	676	730	790
KM	179	193	243	261	311	341	345	390	412	472

尺寸说明

以上尺寸为直联普通电机和制动电机尺寸；  
G1B,KB为制动电机尺寸,其余为普通电机尺寸；  
防爆电机, 辊道电机, 船用电机等须加过渡法兰, 见243页。

ATTENTION

Dimensions of general and brake motor shown in upon table, the others like explosion, roller, or marine motor coupled by adaptor, the dimensions on page 243.



安装尺寸

Mounting Dimensions

**YF87...**

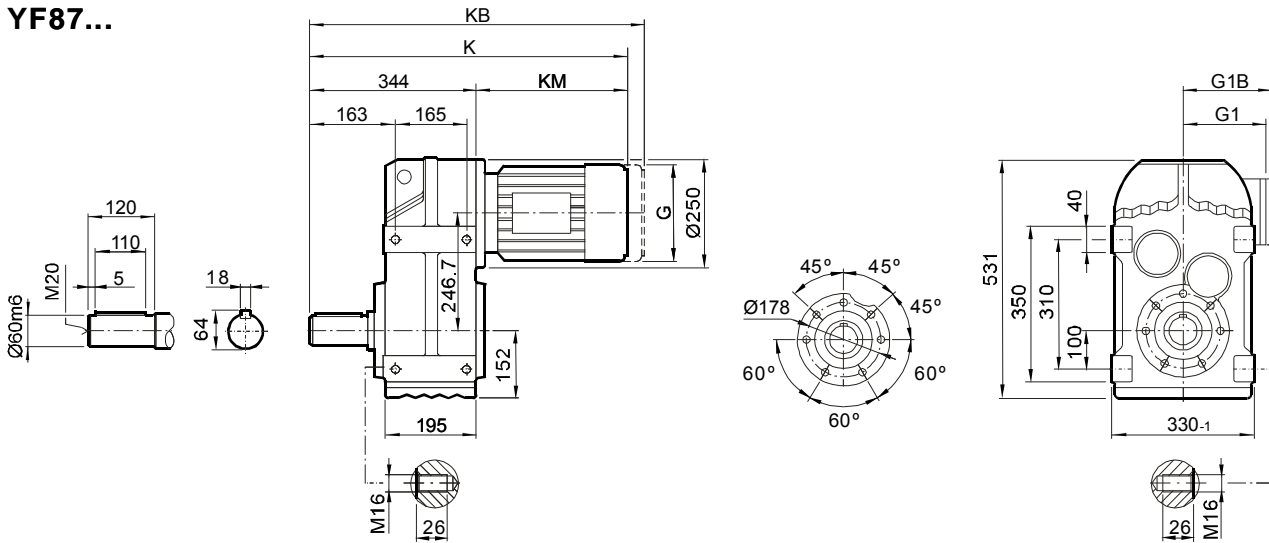

**YFA87B...**

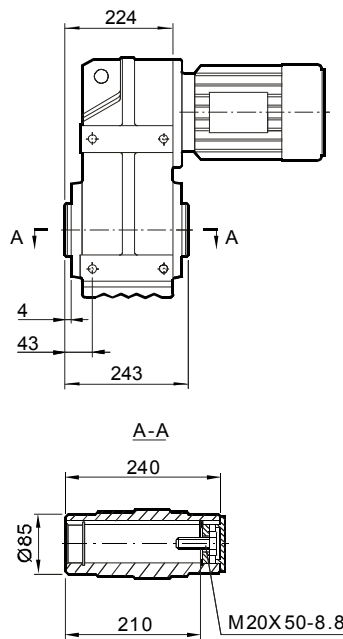

**YFH87B...**

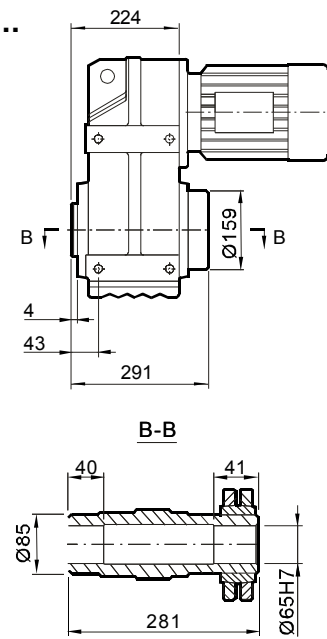

尺寸 Dimensions	电机规格 Motor frame									
	80	90	100M	100L	112M	132S	132M	160M	160L	180
<b>G</b>	145	197	197	197	221	221	275	275	275	275
<b>G1</b>	122	154	166	166	179	179	230	230	230	230
<b>G1B</b>	127	161	166	166	182	182	230	230	230	230
<b>K</b>	582	601	651	681	684	729	751	811	858	930
<b>KB</b>	646	686	736	766	764	809	863	923	1014	1086
<b>KM</b>	238	257	307	337	340	385	407	467	514	586

尺寸说明

以上尺寸为直联普通电机和制动电机尺寸；  
G1B,KB为制动电机尺寸,其余为普通电机尺寸；  
防爆电机, 辊道电机, 船用电机等须加过渡法兰, 见243页。

**ATTENTION**

Dimensions of general and brake motor shown in upon table,  
the others like explosion, roller, or marine motor coupled by  
adaptor, the dimensions on page 243.



安装尺寸

Mounting Dimensions

YFF87...

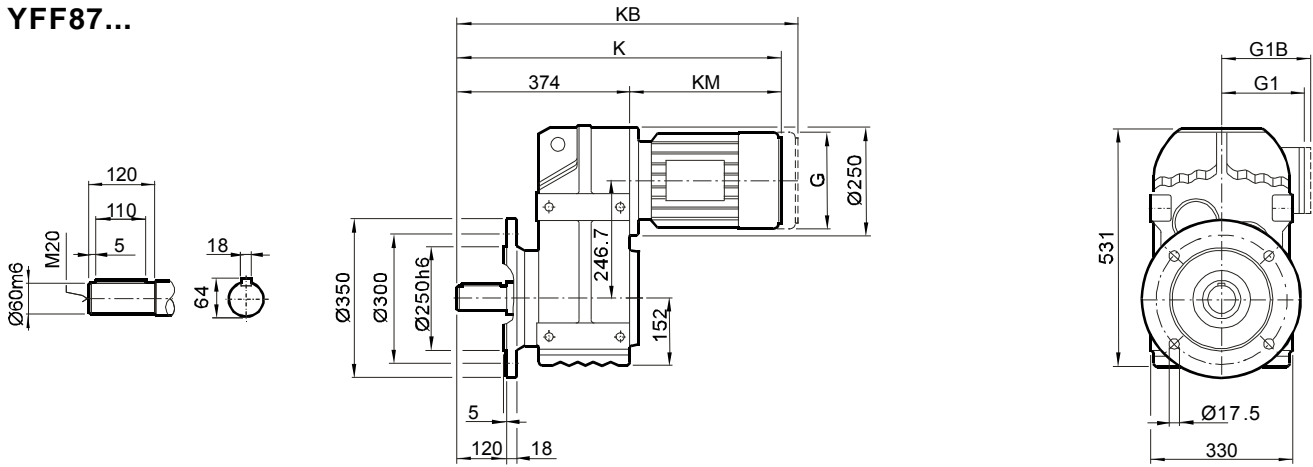

YFAF87...

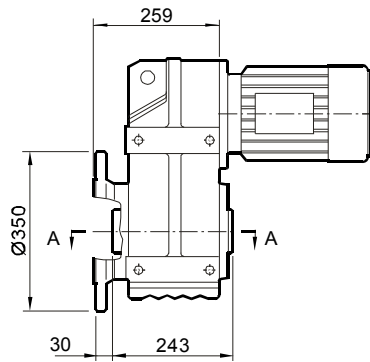

YFHF87...

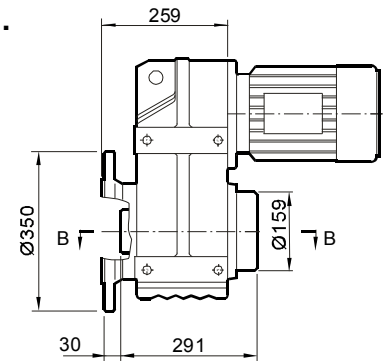

A-A

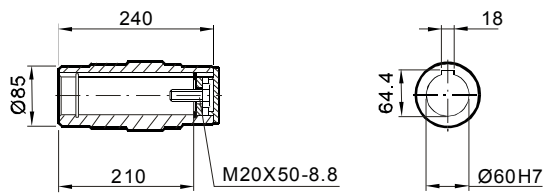

B-B

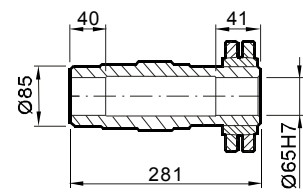

尺寸 Dimensions	电机规格 Motor frame									
	80	90	100M	100L	112M	132S	132M	160M	160L	180
G	145	197	197	197	221	221	275	275	275	275
G1	122	154	166	166	179	179	230	230	230	230
G1B	127	161	166	166	182	182	230	230	230	230
K	612	631	681	711	714	759	781	841	888	960
KB	676	716	766	796	794	839	893	953	1044	1116
KM	238	257	307	337	340	385	407	467	514	586

尺寸说明

以上尺寸为直联普通电机和制动电机尺寸；  
G1B,KB为制动电机尺寸,其余为普通电机尺寸；  
防爆电机, 辊道电机, 船用电机等须加过渡法兰, 见243页。

ATTENTION

Dimensions of general and brake motor shown in upon table, the others like explosion, roller, or marine motor coupled by adaptor, the dimensions on page 243.



安装尺寸

Mounting Dimensions

YFA87...

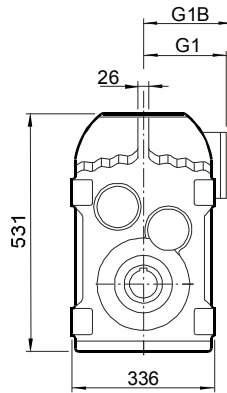
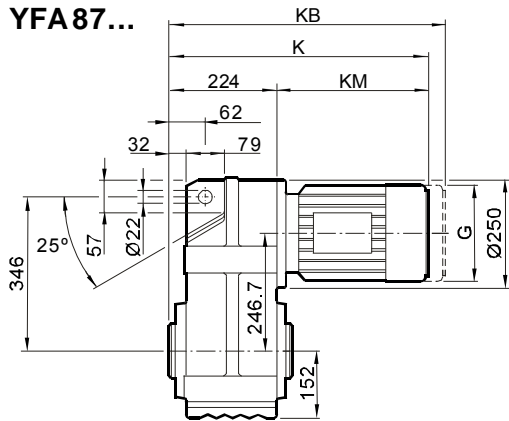

YF...87/G...

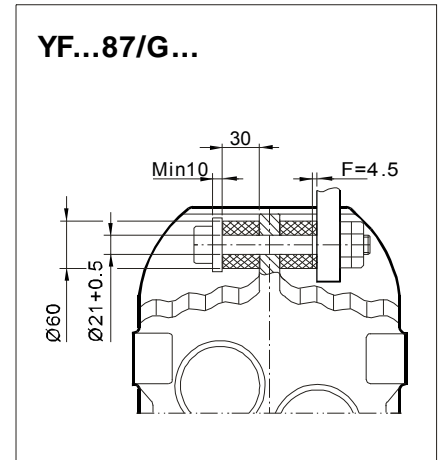

YFA87...

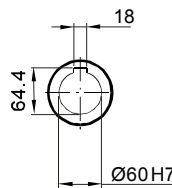
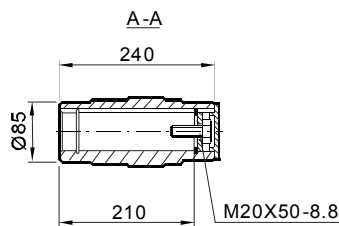
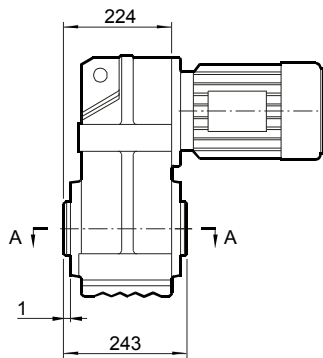

YFH87...

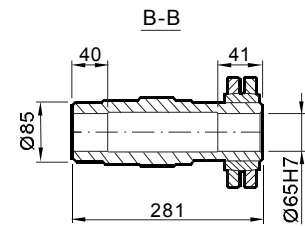
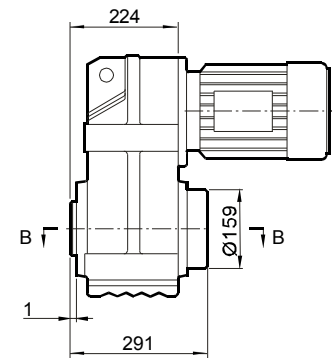

尺寸 Dimensions	电机规格 Motor frame									
	80	90	100M	100L	112M	132S	132M	160M	160L	180
G	145	197	197	197	221	221	275	275	275	275
G1	122	154	166	166	179	179	230	230	230	230
G1B	127	161	166	166	182	182	230	230	230	230
K	462	481	561	564	609	631	691	691	738	810
KB	526	566	646	644	689	743	803	803	894	966
KM	238	257	307	337	340	385	407	467	514	586

尺寸说明

以上尺寸为直联普通电机和制动电机尺寸；  
G1B,KB为制动电机尺寸,其余为普通电机尺寸；  
防爆电机, 辊道电机, 船用电机等须加过渡法兰, 见243页。

ATTENTION

Dimensions of general and brake motor shown in upon table, the others like explosion, roller, or marine motor coupled by adaptor, the dimensions on page 243.



安装尺寸

Mounting Dimensions

YFAZ87...

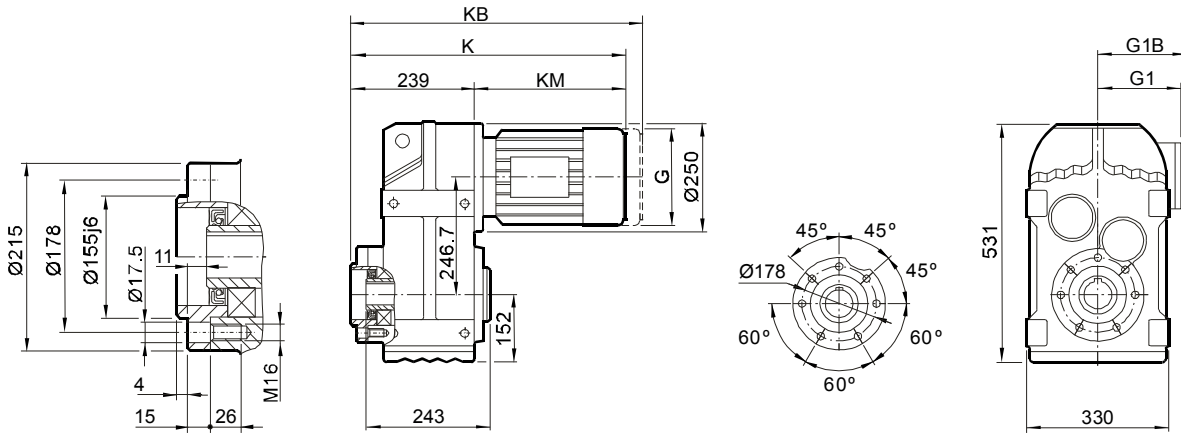

YFAZ87...

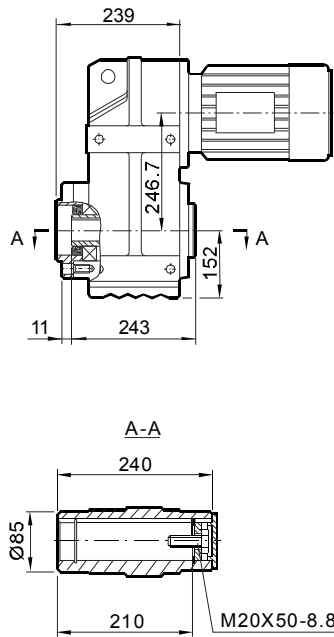

YFHZ87...

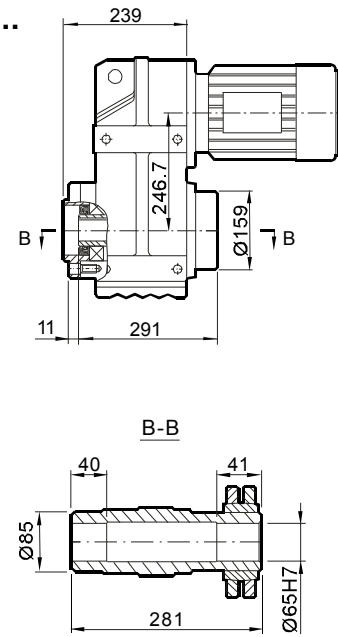

尺寸 Dimension s	电机规格 Motor frame									
	80	90	100M	100L	112M	132S	132M	160M	160L	180
G	145	197	197	197	221	221	275	275	275	275
G1	122	154	166	166	179	179	230	230	230	230
G1B	127	161	166	166	182	182	230	230	230	230
K	477	496	546	576	579	624	646	706	753	825
KB	541	581	631	661	659	704	758	818	909	981
KM	238	257	307	337	340	385	407	467	514	586

尺寸说明

以上尺寸为直联普通电机和制动电机尺寸；  
G1B,KB为制动电机尺寸,其余为普通电机尺寸；  
防爆电机, 辊道电机, 船用电机等须加过渡法兰, 见243页。

ATTENTION

Dimensions of general and brake motor shown in upon table,  
the others like explosion, roller, or marine motor coupled by  
adaptor, the dimensions on page 243.



安装尺寸

Mounting Dimensions

YF97...

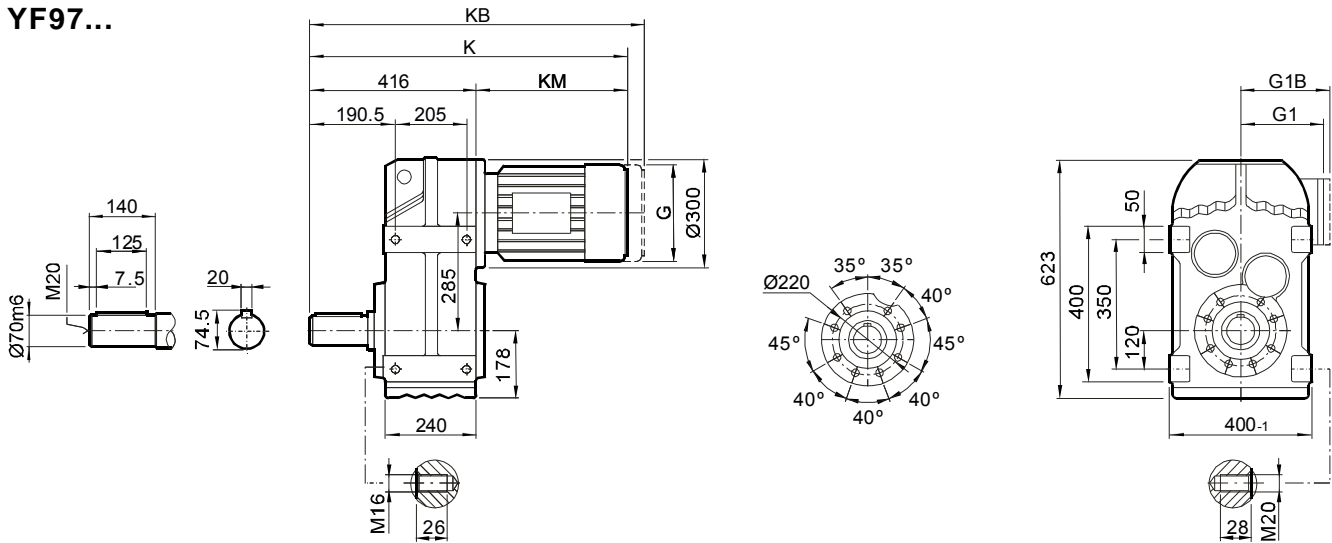

YFA97B...

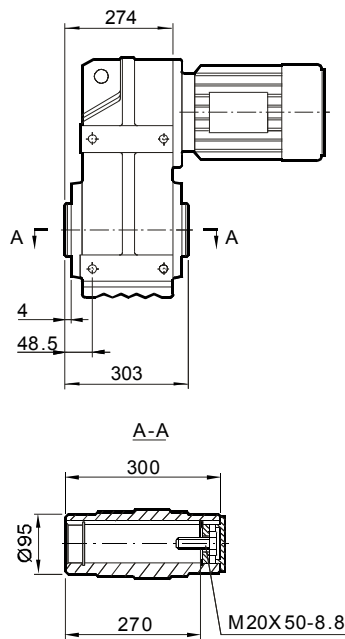

YFH97B...

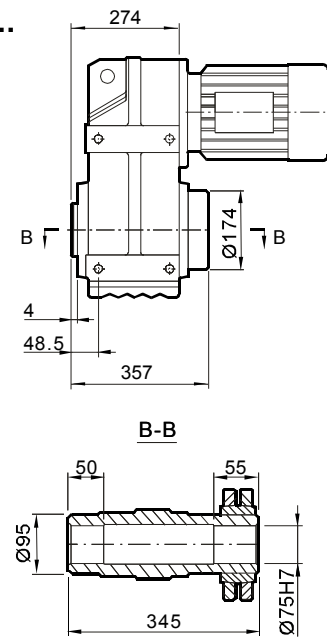

尺寸 Dimensions	电机规格 Motor frame									
	90	100M	100L	112M	132S	132M	160M	160L	180	200
G	197	197	197	221	221	275	275	275	275	275
G1	154	166	166	179	179	230	230	230	230	230
G1B	161	166	166	182	182	230	230	230	230	230
K	667	717	747	751	796	818	878	925	997	1045
KB	752	802	832	831	876	930	990	1081	1153	1201
KM	251	301	331	335	380	402	462	509	581	629

尺寸说明

以上尺寸为直联普通电机和制动电机尺寸；  
G1B,KB为制动电机尺寸,其余为普通电机尺寸；  
防爆电机, 辊道电机, 船用电机等须加过渡法兰, 见243页。

ATTENTION

Dimensions of general and brake motor shown in upon table,  
the others like explosion, roller, or marine motor coupled by  
adaptor, the dimensions on page 243.



安装尺寸

Mounting Dimensions

YFF97...

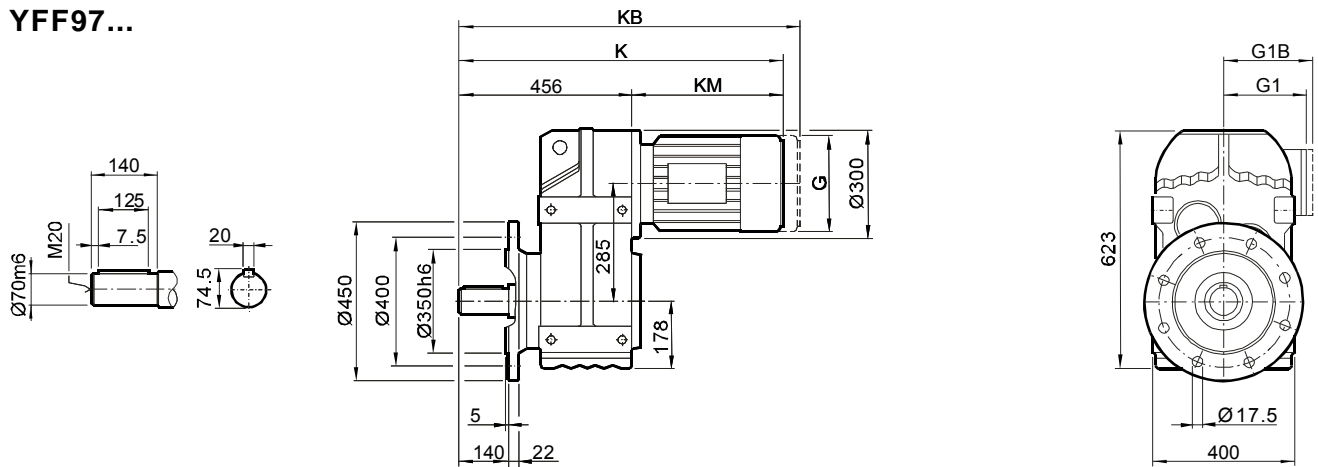

YFAF97...

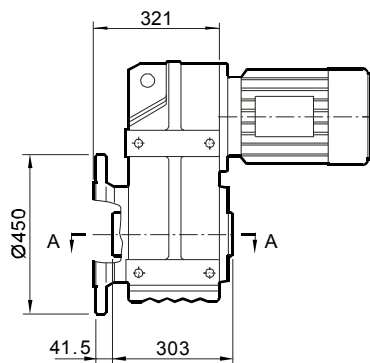

YFHF97...

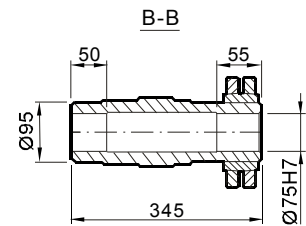
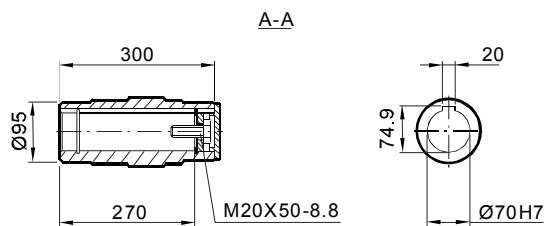
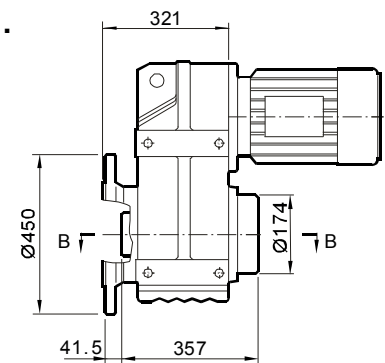

尺寸 Dimensions	电机规格 Motor frame									
	90	100M	100L	112M	132S	132M	160M	160L	180	200
G	197	197	197	221	221	275	275	275	275	275
G1	154	166	166	179	179	230	230	230	230	230
G1B	161	166	166	182	182	230	230	230	230	230
K	707	757	787	791	836	858	918	965	1037	1085
KB	792	842	872	871	916	970	1030	1121	1193	1241
KM	251	301	331	335	380	402	462	509	581	629

尺寸说明

以上尺寸为直联普通电机和制动电机尺寸；  
G1B,KB为制动电机尺寸,其余为普通电机尺寸；  
防爆电机, 辊道电机, 船用电机等须加过渡法兰, 见243页。

ATTENTION

Dimensions of general and brake motor shown in upon table, the others like explosion, roller, or marine motor coupled by adaptor, the dimensions on page 243.



安装尺寸

Mounting Dimensions

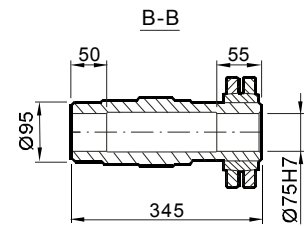
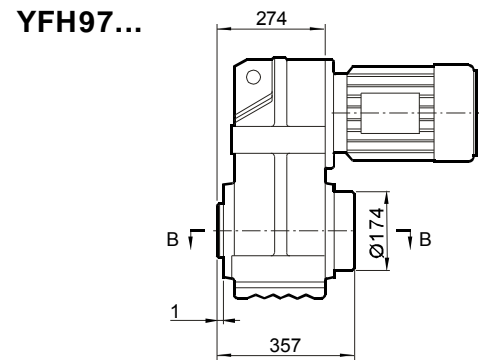
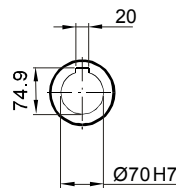
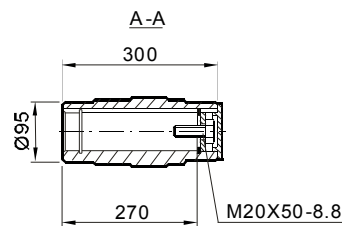
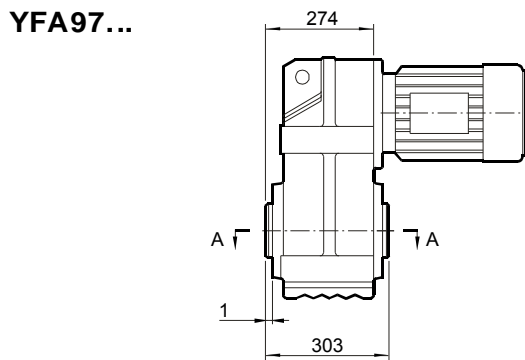
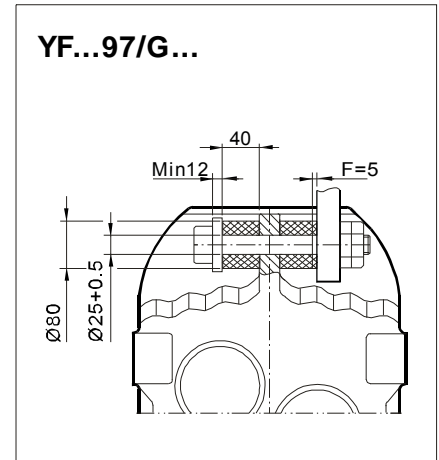
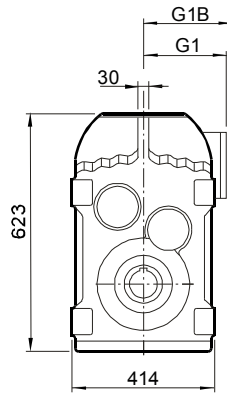
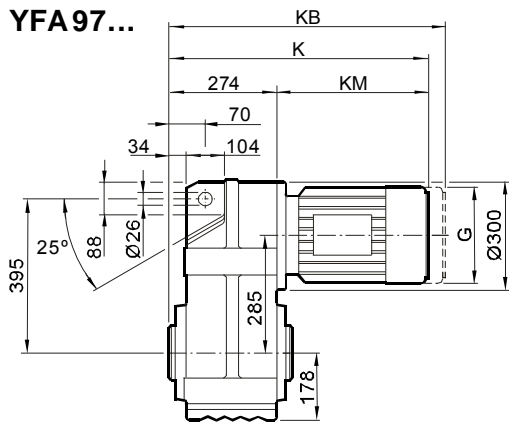

尺寸 Dimensions	电机规格 Motor frame									
	90	100M	100L	112M	132S	132M	160M	160L	180	200
<b>G</b>	197	197	197	221	221	275	275	275	275	275
<b>G1</b>	154	166	166	179	179	230	230	230	230	230
<b>G1B</b>	161	166	166	182	182	230	230	230	230	230
<b>K</b>	525	575	605	609	654	676	736	783	855	903
<b>KB</b>	610	660	690	689	734	788	848	939	1011	1059
<b>KM</b>	251	301	331	335	380	402	462	509	581	629

尺寸说明

以上尺寸为直联普通电机和制动电机尺寸；  
G1B,KB为制动电机尺寸,其余为普通电机尺寸；  
防爆电机, 辊道电机, 船用电机等须加过渡法兰, 见243页。

ATTENTION

Dimensions of general and brake motor shown in upon table, the others like explosion, roller, or marine motor coupled by adaptor, the dimensions on page 243.



安装尺寸

Mounting Dimensions

YFAZ97...

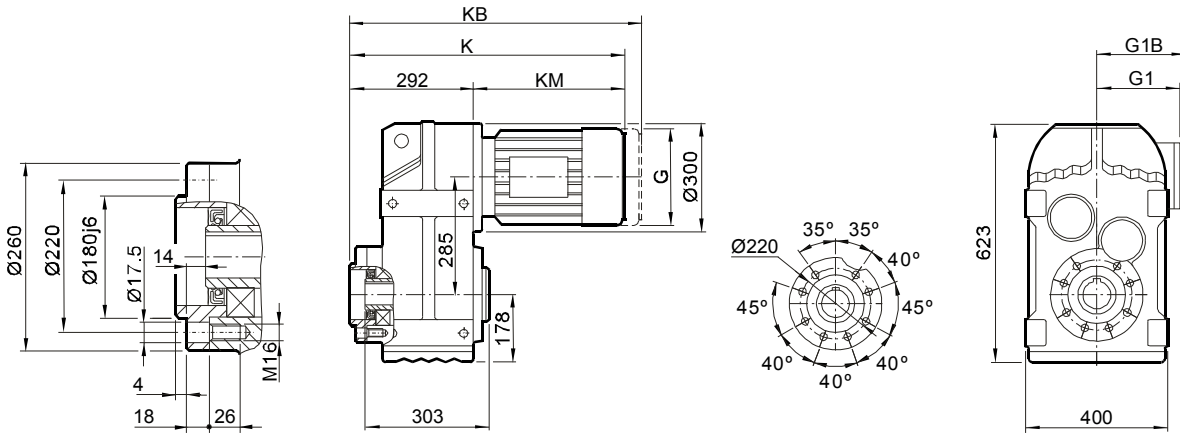

YFAZ97...

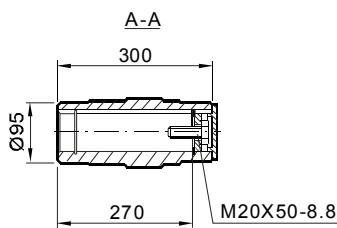
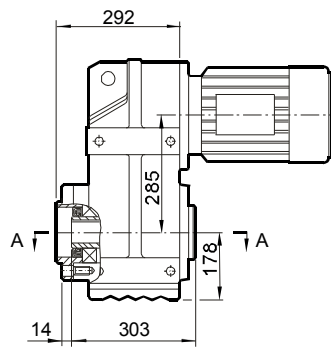

YFHZ97...

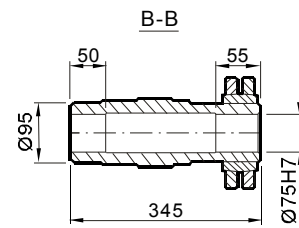
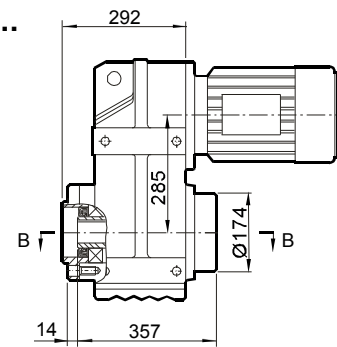

尺寸 Dimensions	电机规格 Motor frame									
	90	100M	100L	112M	132S	132M	160M	160L	180	200
<b>G</b>	197	197	197	221	221	275	275	275	275	275
<b>G1</b>	154	166	166	179	179	230	230	230	230	230
<b>G1B</b>	161	166	166	182	182	230	230	230	230	230
<b>K</b>	543	593	623	627	672	694	754	801	873	921
<b>KB</b>	628	678	708	707	752	806	866	957	1029	1077
<b>KM</b>	251	301	331	335	380	402	462	509	581	629

尺寸说明

以上尺寸为直联普通电机和制动电机尺寸；  
G1B,KB为制动电机尺寸,其余为普通电机尺寸；  
防爆电机, 辊道电机, 船用电机等须加过渡法兰, 见243页。

ATTENTION

Dimensions of general and brake motor shown in upon table,  
the others like explosion, roller, or marine motor coupled by  
adaptor, the dimensions on page 243.



安装尺寸

Mounting Dimensions

YF107...

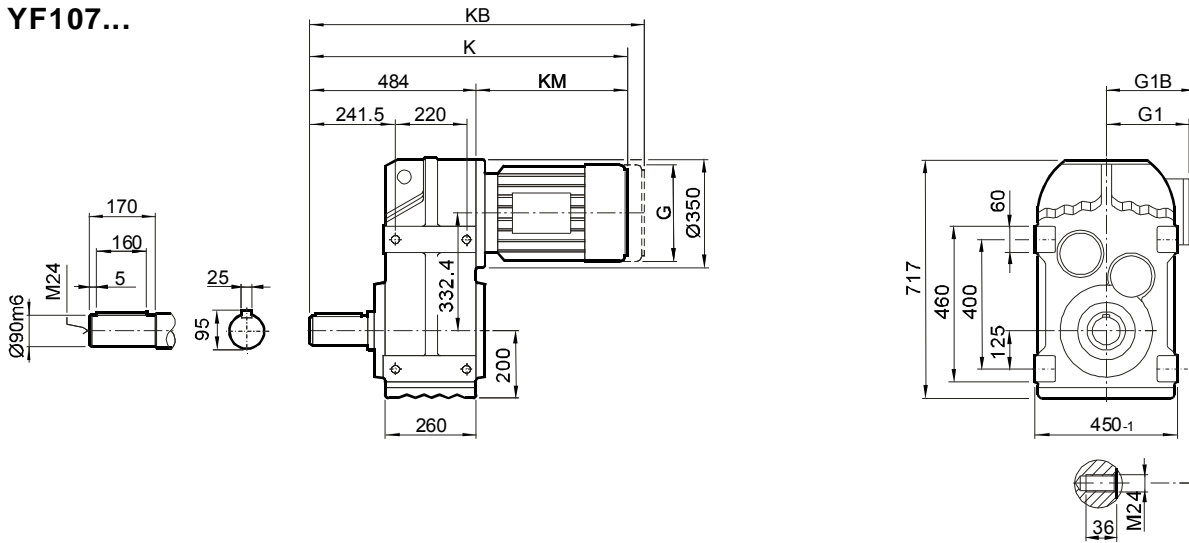

YFA107B...

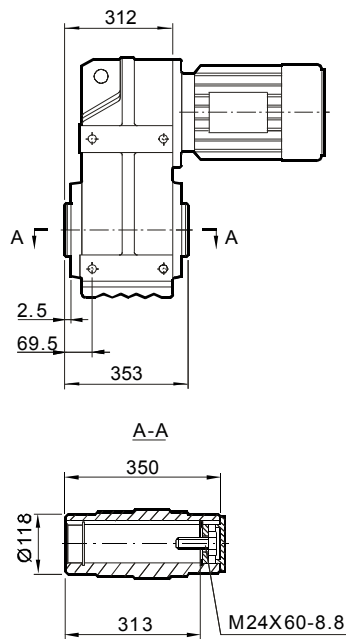

YFH107B...

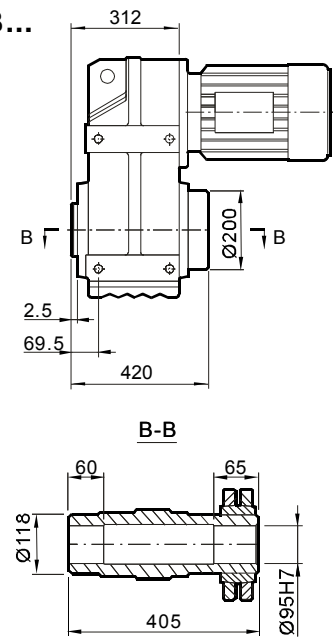

尺寸 Dimensions	电机规格 Motor frame									
	100M	100L	112M	132S	132M	160M	160L	180	200	225
G	197	197	221	221	275	275	275	275	275	275
G1	166	166	179	179	230	230	230	230	230	230
G1B	166	166	182	182	230	230	230	230	230	230
K	779	809	813	858	880	940	987	1059	1107	1189
KB	864	894	893	938	992	1052	1143	1215	1263	1345
KM	295	325	329	374	396	456	503	575	623	705

尺寸说明

以上尺寸为直联普通电机和制动电机尺寸；  
G1B,KB为制动电机尺寸,其余为普通电机尺寸；  
防爆电机, 辊道电机, 船用电机等须加过渡法兰, 见244页。

ATTENTION

Dimensions of general and brake motor shown in upon table,  
the others like explosion, roller, or marine motor coupled by  
adaptor, the dimensions on page 244.



安装尺寸

Mounting Dimensions

**YFF107...**

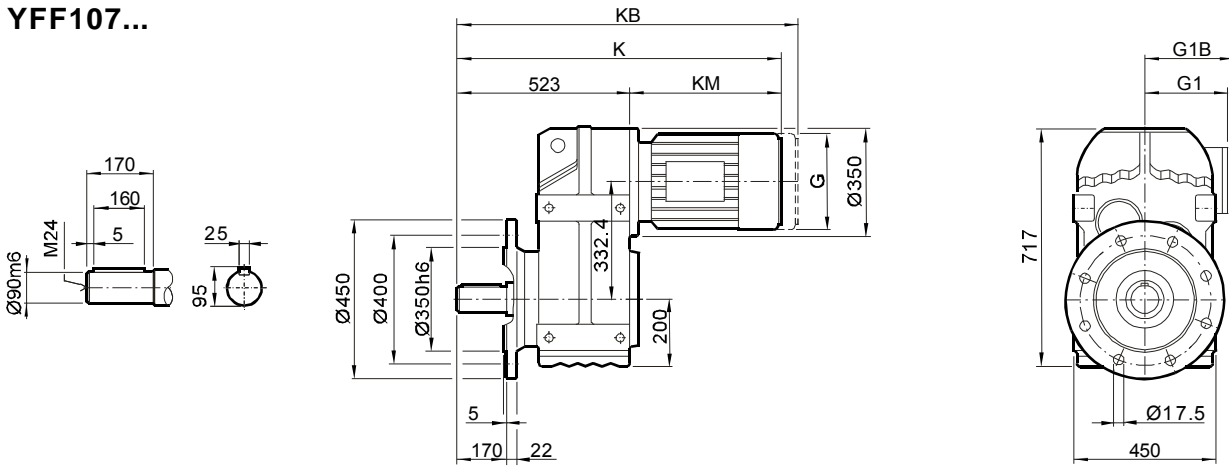

**YFAF107...**

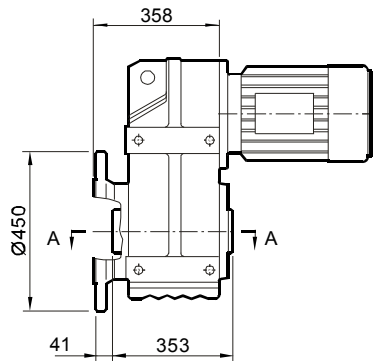

**YFHF107...**

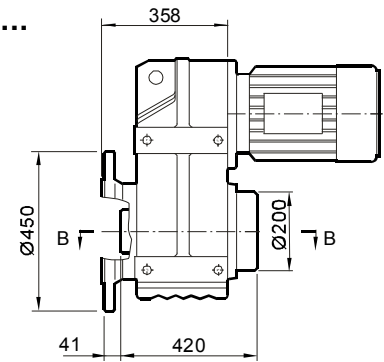

A-A

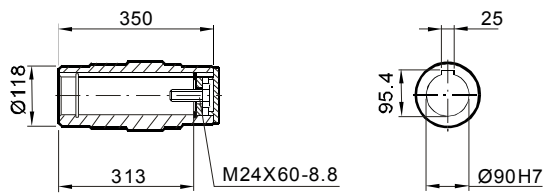

B-B

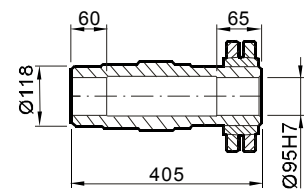

尺寸 Dimensions	电机规格 Motor frame									
	100M	100L	112M	132S	132M	160M	160L	180	200	225
<b>G</b>	197	197	221	221	275	275	275	275	275	275
<b>G1</b>	166	166	179	179	230	230	230	230	230	230
<b>G1B</b>	166	166	182	182	230	230	230	230	230	230
<b>K</b>	818	848	852	897	919	979	1026	1098	1146	1228
<b>KB</b>	903	933	932	977	1031	1091	1182	1254	1302	1384
<b>KM</b>	295	325	329	374	396	456	503	575	623	705

尺寸说明

以上尺寸为直联普通电机和制动电机尺寸；  
G1B,KB为制动电机尺寸,其余为普通电机尺寸；  
防爆电机, 辊道电机, 船用电机等须加过渡法兰, 见244页。

ATTENTION

Dimensions of general and brake motor shown in upon table, the others like explosion, roller, or marine motor coupled by adaptor, the dimensions on page 244.



安装尺寸

Mounting Dimensions

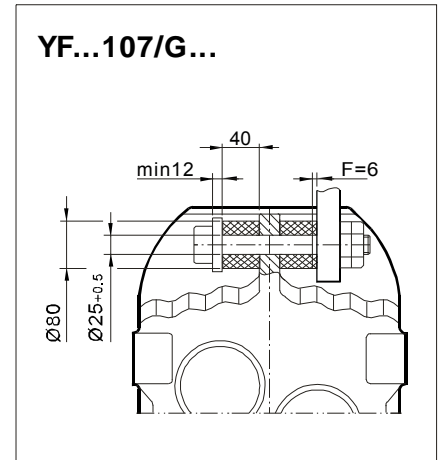
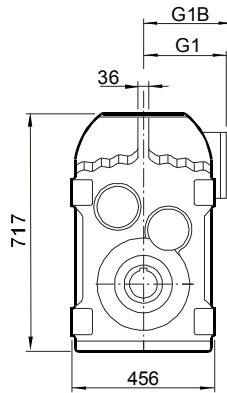
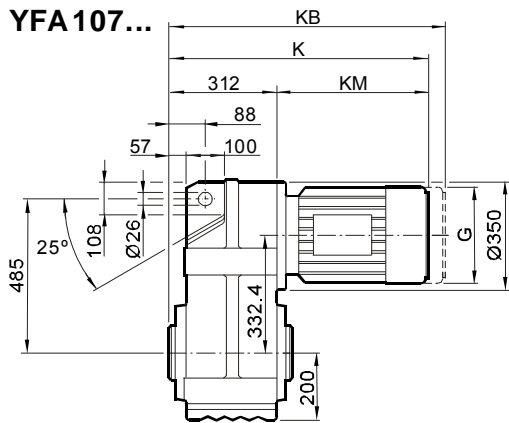

YFA107...

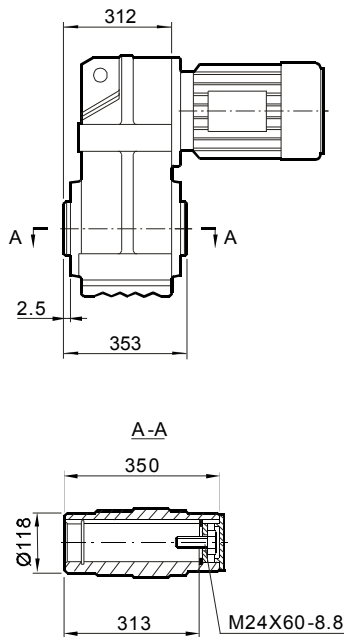

YFH107...

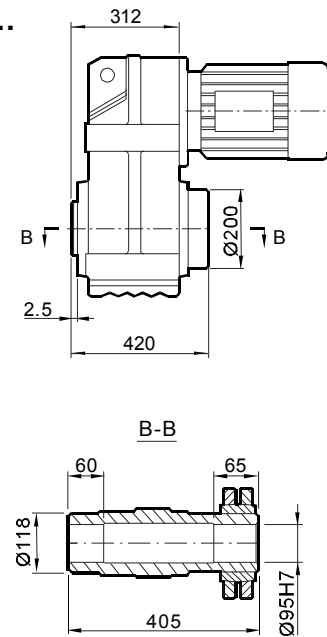

尺寸 Dimensions	电机规格 Motor frame									
	100M	100L	112M	132S	132M	160M	160L	180..	200..	225..
G	197	197	221	221	275	275	331	331	394	394
G1	166	166	176	176	230	230	259	253	285	289
G1B	166	166	182	182	230	230	259	253	285	289
K	607	637	641	686	708	768	815	887	935	1017
KB	692	722	721	766	820	880	971	1043	1091	1173
KM	295	325	329	374	396	456	503	575	623	705

尺寸说明

以上尺寸为直联普通电机和制动电机尺寸；  
G1B,KB为制动电机尺寸,其余为普通电机尺寸；  
防爆电机, 辊道电机, 船用电机等须加过渡法兰, 见244页。

ATTENTION

Dimensions of general and brake motor shown in upon table,  
the others like explosion, roller, or marine motor coupled by  
adaptor, the dimensions on page 244.



安装尺寸

Mounting Dimensions

YFAZ107...

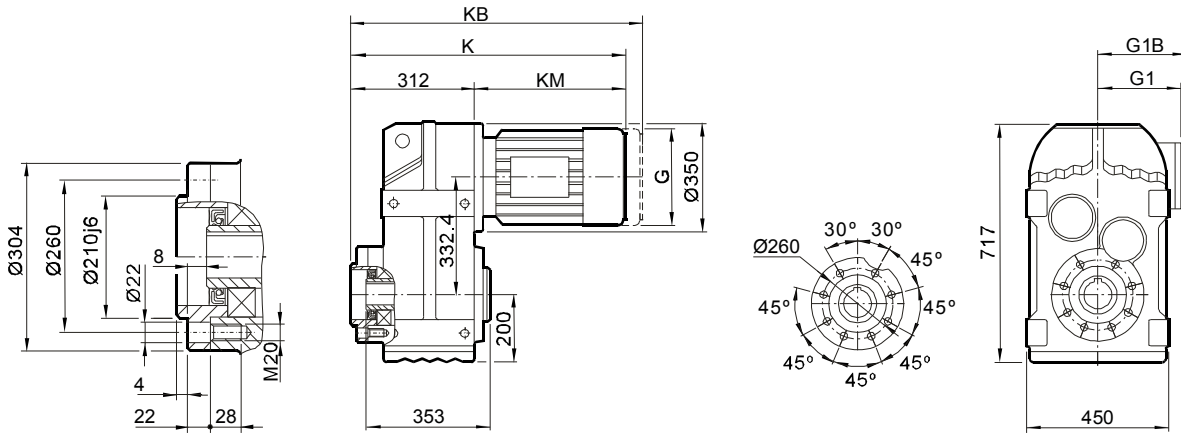

YFAZ107...

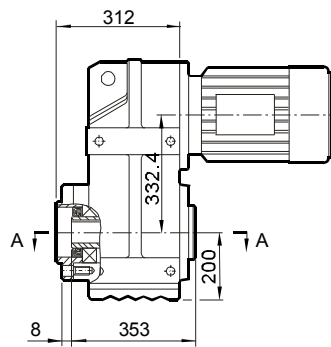

YFHZ107...

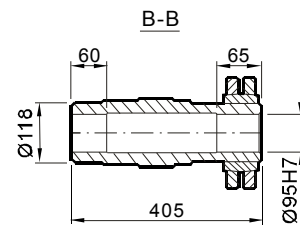
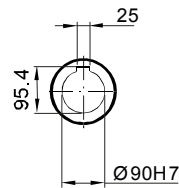
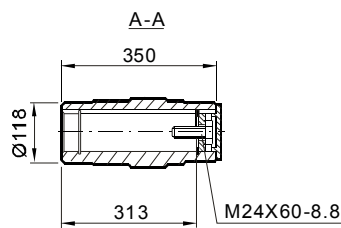
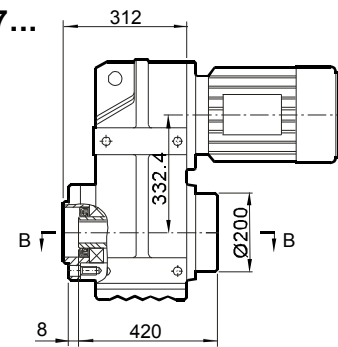

尺寸 Dimensions	电机规格 Motor frame									
	100M	100L	112M	132S	132M	160M	160L	180	200	225
G	197	197	221	221	275	275	275	275	275	275
G1	166	166	179	179	230	230	230	230	230	230
G1B	166	166	182	182	230	230	230	230	230	230
K	607	637	641	686	708	768	815	887	935	1017
KB	692	722	721	766	820	880	971	1043	1091	1173
KM	295	325	329	374	396	456	503	575	623	705

尺寸说明

以上尺寸为直联普通电机和制动电机尺寸；  
G1B,KB为制动电机尺寸,其余为普通电机尺寸；  
防爆电机, 辊道电机, 船用电机等须加过渡法兰, 见244页。

ATTENTION

Dimensions of general and brake motor shown in upon table,  
the others like explosion, roller, or marine motor coupled by  
adaptor, the dimensions on page 244.



安装尺寸

Mounting Dimensions

YF127...

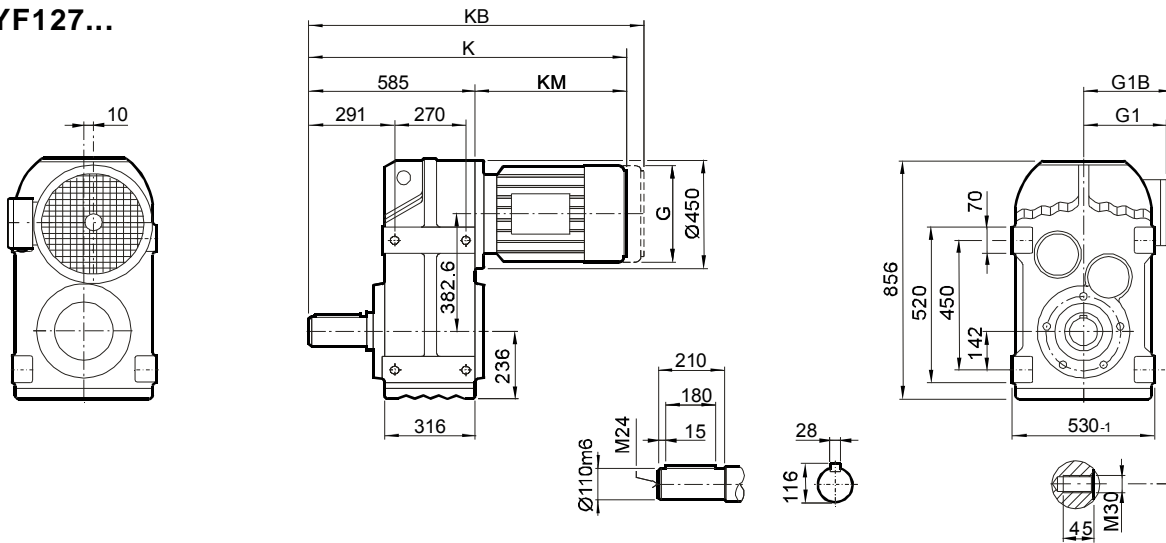

YFA127B...

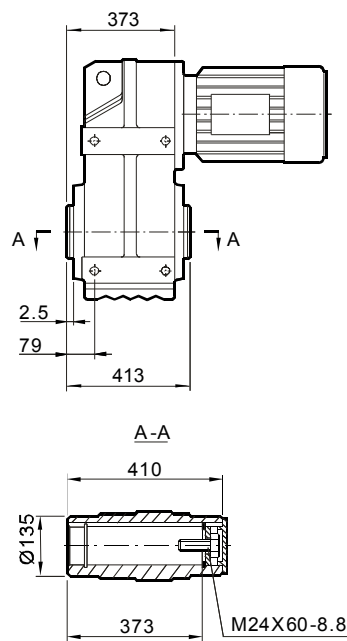

YFH127B...

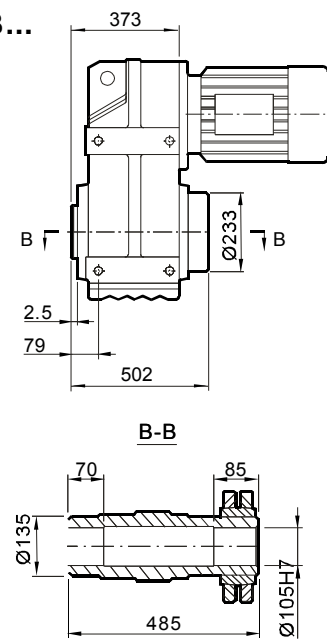

尺寸 Dimensions	电机规格 Motor frame									
	132M	160M	160L	180..	200..	225..	250M	280S	280M	
G	275	275	331	275	394	394	480	537	537	
G1	230	230	259	253	285	289	350	382	382	
G1B	230	230	259	253	285	289	350	382	382	
K	966	1026	1073	1145	1193	1275	1362	1440	1491	
KB	1078	1138	1229	1301	1349	1431	1582	1651	1702	
KM	381	441	488	560	608	690	777	855	906	

尺寸说明

以上尺寸为直联普通电机和制动电机尺寸；  
G1B,KB为制动电机尺寸,其余为普通电机尺寸；  
防爆电机, 辊道电机, 船用电机等须加过渡法兰, 见244页。

ATTENTION

Dimensions of general and brake motor shown in upon table,  
the others like explosion, roller, or marine motor coupled by  
adaptor, the dimensions on page 244.



安装尺寸

Mounting Dimensions

**YFF127...**

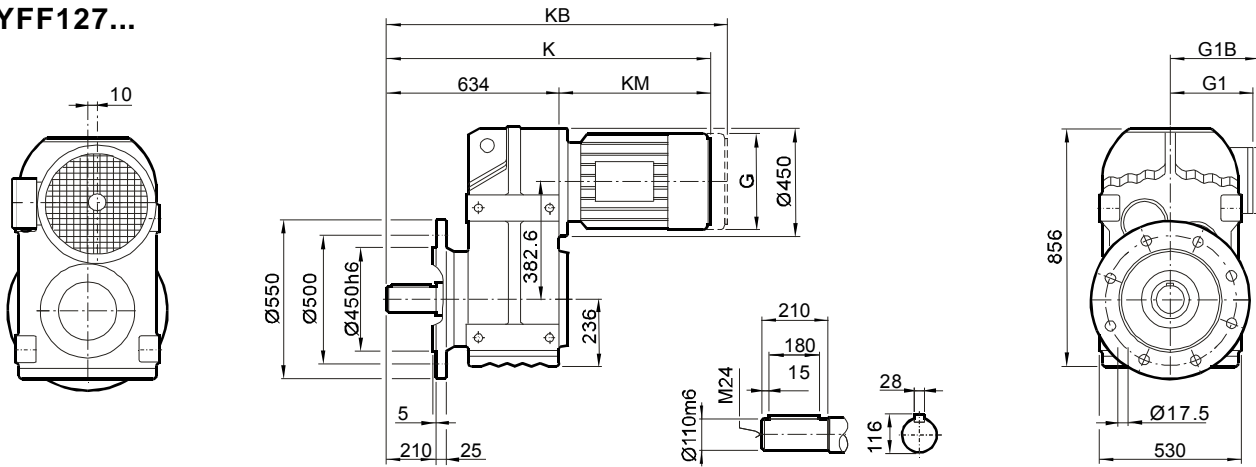

**YFAF127...**

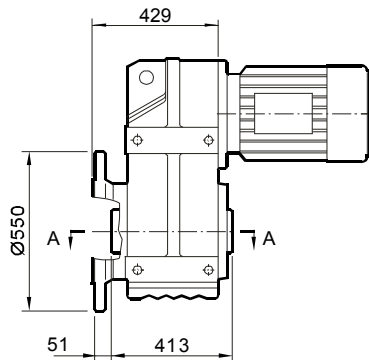

**YFHF127...**

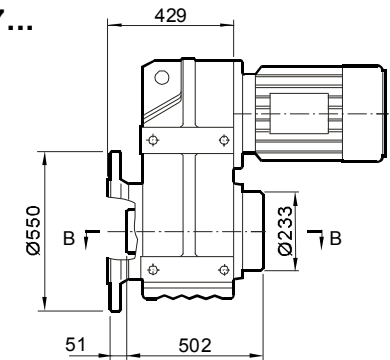

尺寸 Dimensions	电机规格 Motor frame									
	132M	160M	160L	180..	200..	225..	250M	280S	280M	
<b>G</b>	275	275	331	331	394	394	480	537	537	
<b>G1</b>	230	230	259	253	285	289	350	382	382	
<b>G1B</b>	230	230	259	253	285	289	350	382	382	
<b>K</b>	1015	1075	1122	1194	1242	1324	1411	1489	1540	
<b>KB</b>	1127	1187	1278	1350	1398	1480	1632	1700	1751	
<b>KM</b>	381	441	488	560	608	690	777	855	906	

尺寸说明

以上尺寸为直联普通电机和制动电机尺寸；  
G1B,KB为制动电机尺寸,其余为普通电机尺寸；  
防爆电机, 辊道电机, 船用电机等须加过渡法兰, 见244页。

**ATTENTION**

Dimensions of general and brake motor shown in upon table, the others like explosion, roller, or marine motor coupled by adaptor, the dimensions on page 244.



安装尺寸

Mounting Dimensions

YFA127...

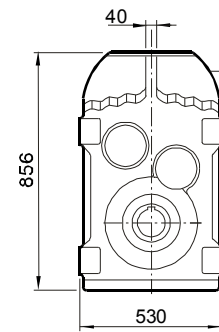
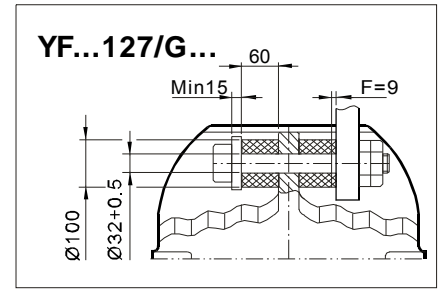
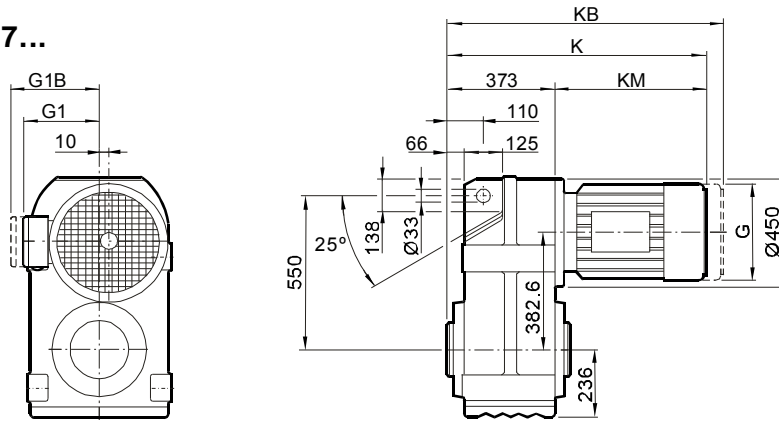

YFA127...

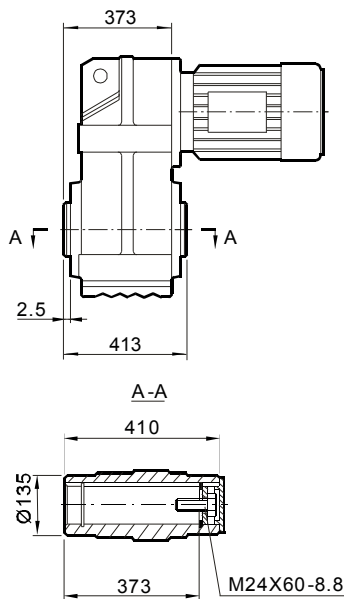

YFH127...

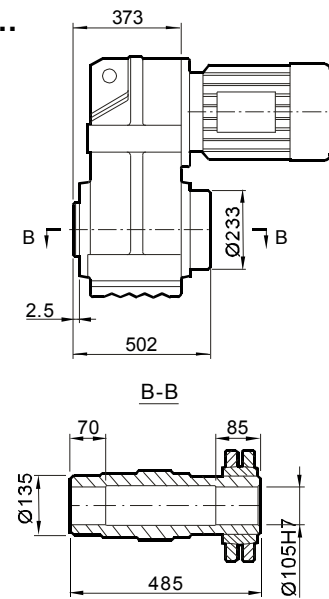

尺寸 Dimensions	电机规格 Motor frame									
	132M	160M	160L	180..	200..	225..	250M	280S	280M	
G	275	275	331	331	394	394	480	537	537	
G1	230	230	259	253	285	289	350	382	382	
G1B	230	230	259	253	285	289	350	382	382	
K	754	814	861	933	981	1063	1150	1228	1279	
KB	866	926	1017	1089	1137	1219	1371	1439	1490	
KM	381	441	488	560	608	780	777	855	906	

尺寸说明

以上尺寸为直联普通电机和制动电机尺寸；  
G1B,KB为制动电机尺寸,其余为普通电机尺寸；  
防爆电机, 辊道电机, 船用电机等须加过渡法兰, 见244页。

ATTENTION

Dimensions of general and brake motor shown in upon table,  
the others like explosion, roller, or marine motor coupled by  
adaptor, the dimensions on page 244.



安装尺寸

Mounting Dimensions

YFAZ127...

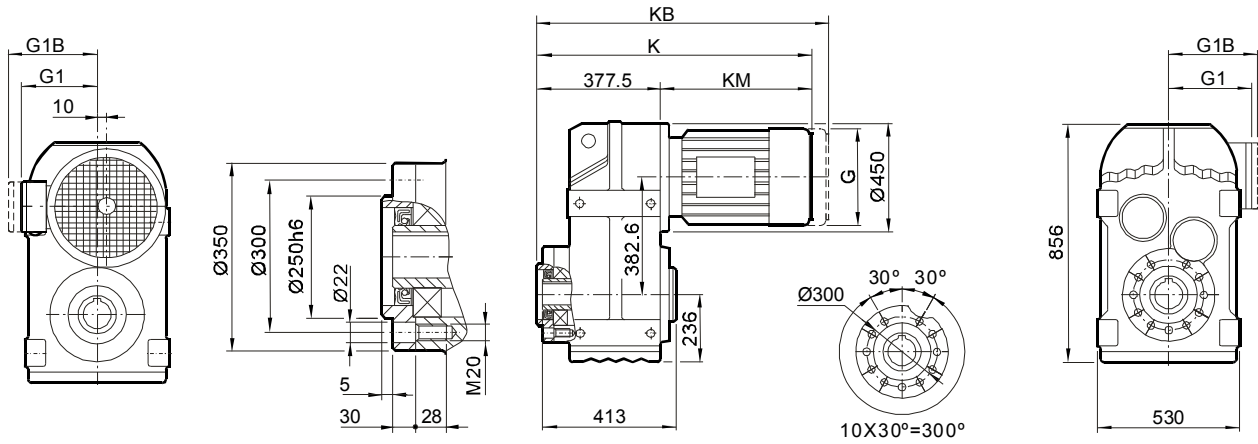

YFAZ127...

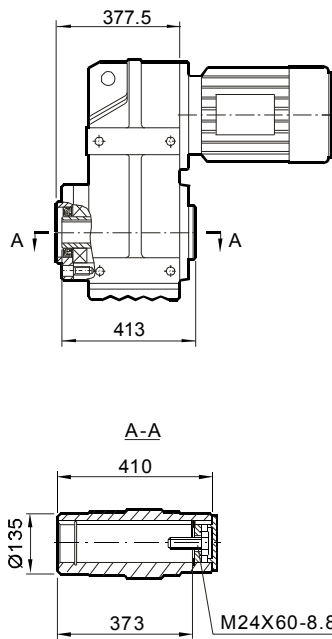

YFHZ127...

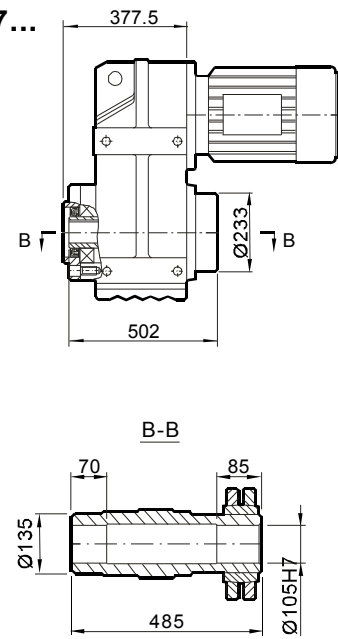

尺寸 Dimensions	电机规格 Motor frame									
	132M	160M	160L	180..	200..	225..	250M	280S	280M	
G	275	275	331	331	394	394	480	537	537	
G1	230	230	259	253	285	289	350	382	382	
G1B	230	230	259	253	285	289	350	382	382	
K	759	819	866	938	986	1068	1155	1233	1284	
KB	871	931	1022	1094	1142	1224	1376	1444	1495	
KM	381	441	488	560	608	780	777	855	906	

尺寸说明

以上尺寸为直联普通电机和制动电机尺寸；  
G1B,KB为制动电机尺寸,其余为普通电机尺寸；  
防爆电机, 辊道电机, 船用电机等须加过渡法兰, 见244页。

ATTENTION

Dimensions of general and brake motor shown in upon table, the others like explosion, roller, or marine motor coupled by adaptor, the dimensions on page 244.



安装尺寸

Mounting Dimensions

YF157...

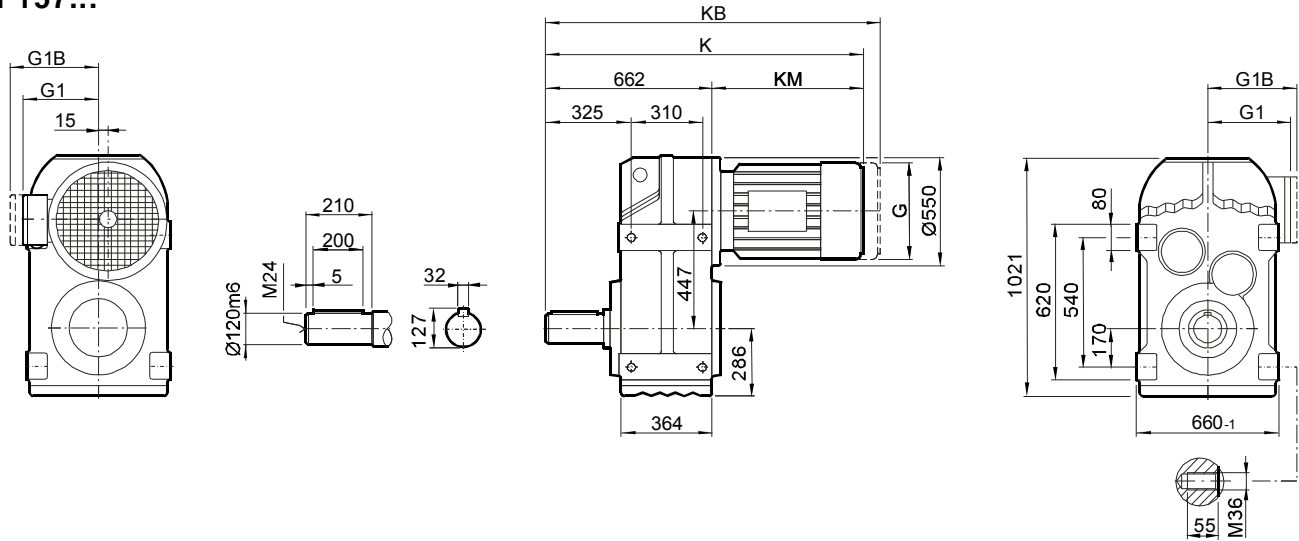

YFA157B...

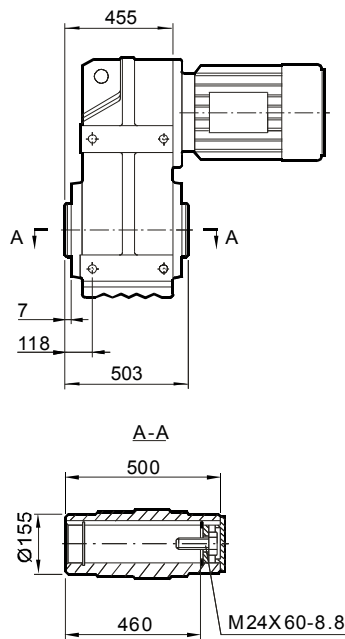

YFH157B...

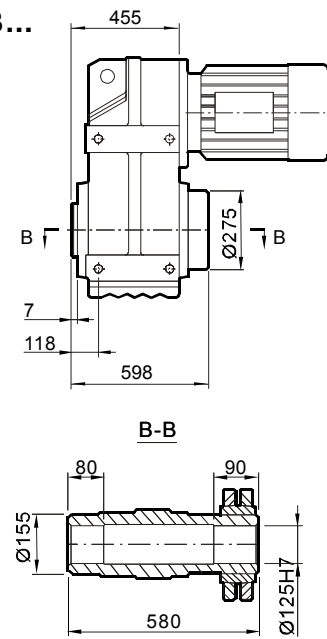

尺寸 Dimensions	电机规格 Motor frame									
	160M	160L	180..	200..	225..	250M	280S	280M	315S	315M
G	275	331	331	394	394	480	537	537	612	612
G1	230	259	253	285	289	350	382	382	430	430
G1B	230	259	253	285	289	350	382	382	430	430
K	1095	1142	1214	1262	1344	1461	1535	1586	1637	1688
KB	1207	1298	1370	1418	1500	1618	1746	1797	1865	1916
KM	433	480	552	600	682	771	873	924	975	1026

尺寸说明

以上尺寸为直联普通电机和制动电机尺寸；  
G1B,KB为制动电机尺寸,其余为普通电机尺寸；  
防爆电机, 辊道电机, 船用电机等须加过渡法兰, 见244页。

ATTENTION

Dimensions of general and brake motor shown in upon table,  
the others like explosion, roller, or marine motor coupled by  
adaptor, the dimensions on page 244.



安装尺寸

Mounting Dimensions

**YFF157...**

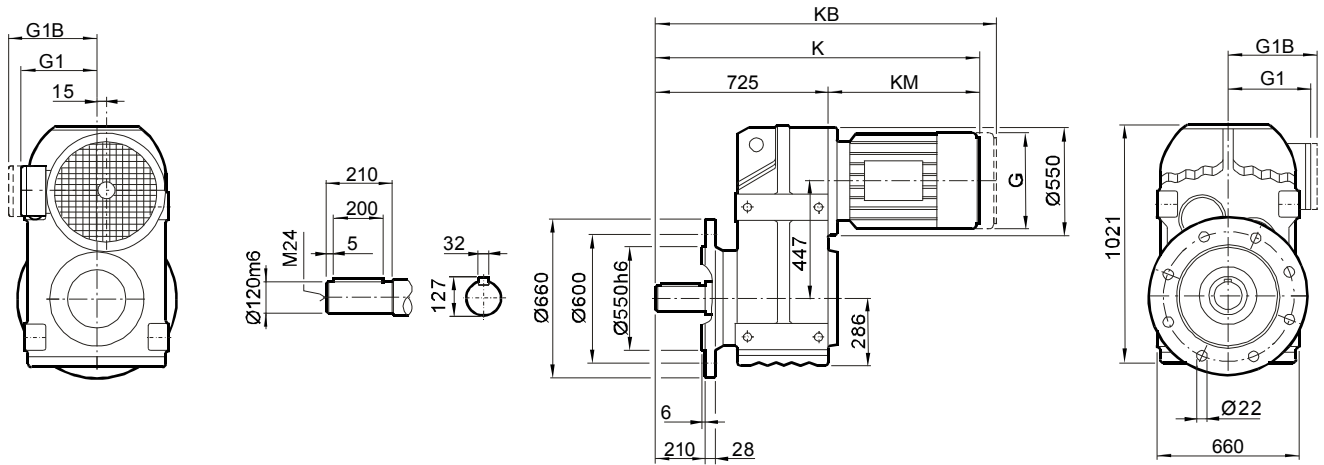

**YFAF157...**

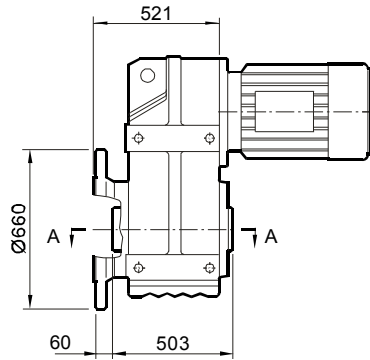

**YFHF157...**

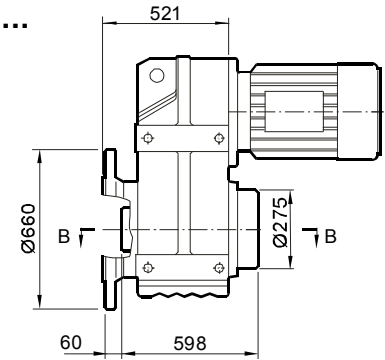

A-A

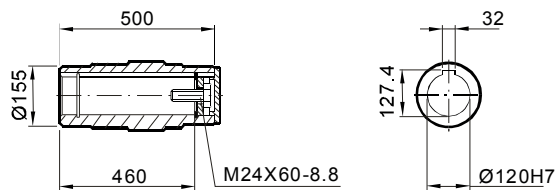

B-B

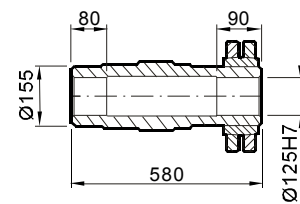

尺寸 Dimensions	电机规格 Motor frame									
	160M	160L	180	200	225	250M	280S	280M	315S	315M
<b>G</b>	275	275	275	275	275	275	275	275	275	275
<b>G1</b>	230	230	230	230	230	230	230	230	230	230
<b>G1B</b>	230	230	230	230	230	230	230	230	230	230
<b>K</b>	1158	1205	1277	1325	1407	1469	1469	1649	1700	1751
<b>KB</b>	1270	1361	1433	1481	1563	1681	1681	1860	1928	1979
<b>KM</b>	433	480	552	600	682	771	771	924	975	1026

尺寸说明

以上尺寸为直联普通电机和制动电机尺寸；  
G1B,KB为制动电机尺寸,其余为普通电机尺寸；  
防爆电机, 辊道电机, 船用电机等须加过渡法兰, 见244页。

**ATTENTION**

Dimensions of general and brake motor shown in upon table,  
the others like explosion, roller, or marine motor coupled by  
adaptor, the dimensions on page 244.



安装尺寸

Mounting Dimensions

YFA157...

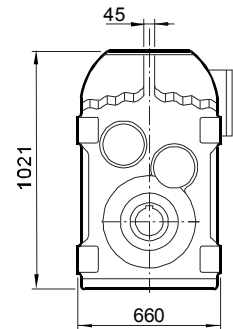
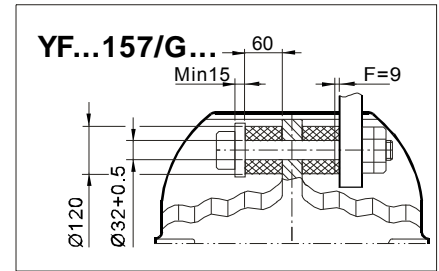
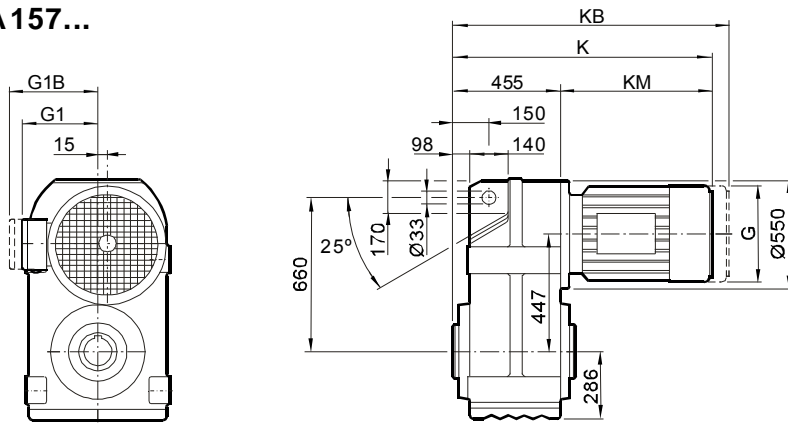

YFA157...

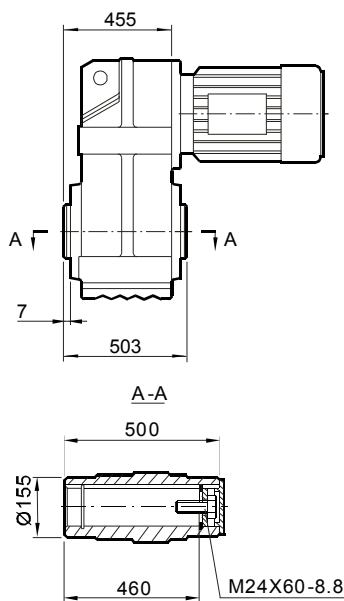

YFH157...

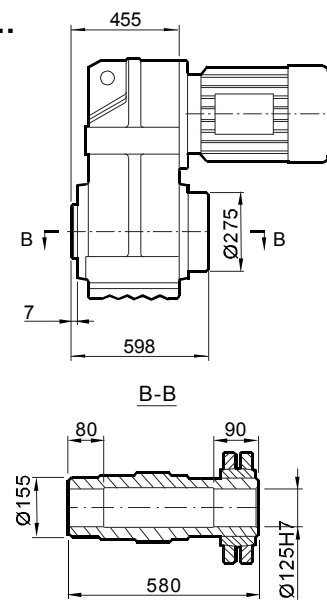

尺寸 Dimensions	电机规格 Motor frame									
	160M	160L	180..	200..	225..	250M	280S	280M	315S	315M
G	275	331	331	394	394	480	537	537	612	612
G1	230	259	259	285	289	350	382	382	430	430
G1B	230	259	259	285	289	350	382	382	430	430
K	888	935	1007	1055	1137	1254	1328	1379	1430	1481
KB	1000	1091	1163	1211	1293	1475	1539	1590	1658	1709
KM	433	480	552	600	682	799	873	924	975	1026

尺寸说明

以上尺寸为直联普通电机和制动电机尺寸；  
G1B,KB为制动电机尺寸,其余为普通电机尺寸；  
防爆电机, 辊道电机, 船用电机等须加过渡法兰, 见244页。

ATTENTION

Dimensions of general and brake motor shown in upon table,  
the others like explosion, roller, or marine motor coupled by  
adaptor, the dimensions on page 244.



安装尺寸

Mounting Dimensions

**YFAZ157...**

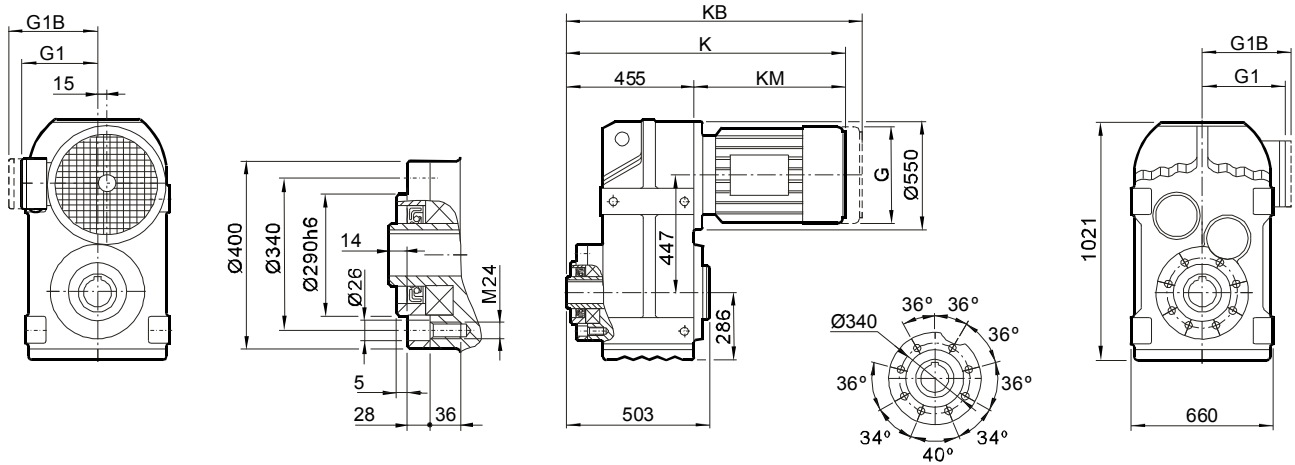

**YFAZ157...**

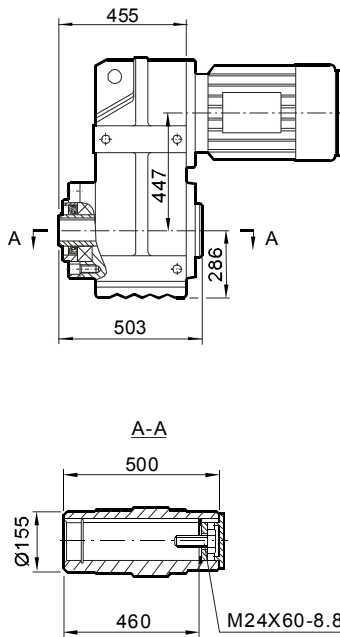

**YFHZ157...**

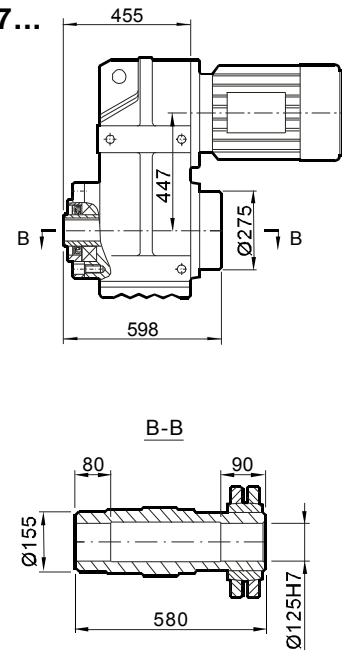

尺寸 Dimensions	电机规格 Motor frame									
	160M	160L	180..	200..	225..	250M	280S	280M	315S	315M
<b>G</b>	275	331	331	394	394	480	537	537	612	612
<b>G1</b>	230	259	259	285	289	350	382	382	430	430
<b>G1B</b>	230	259	259	285	289	350	382	382	430	430
<b>K</b>	888	935	1007	1055	1137	1254	1328	1379	1430	1481
<b>KB</b>	1000	1091	1163	1211	1293	1475	1539	1590	1658	1709
<b>KM</b>	433	480	552	600	682	799	873	924	975	1026

尺寸说明

以上尺寸为直联普通电机和制动电机尺寸；  
G1B,KB为制动电机尺寸,其余为普通电机尺寸；  
防爆电机, 辊道电机, 船用电机等须加过渡法兰, 见244页。

ATTENTION

Dimensions of general and brake motor shown in upon table,  
the others like explosion, roller, or marine motor coupled by  
adaptor, the dimensions on page 244.



安装尺寸

Mounting Dimensions

组合型尺寸

Combinations

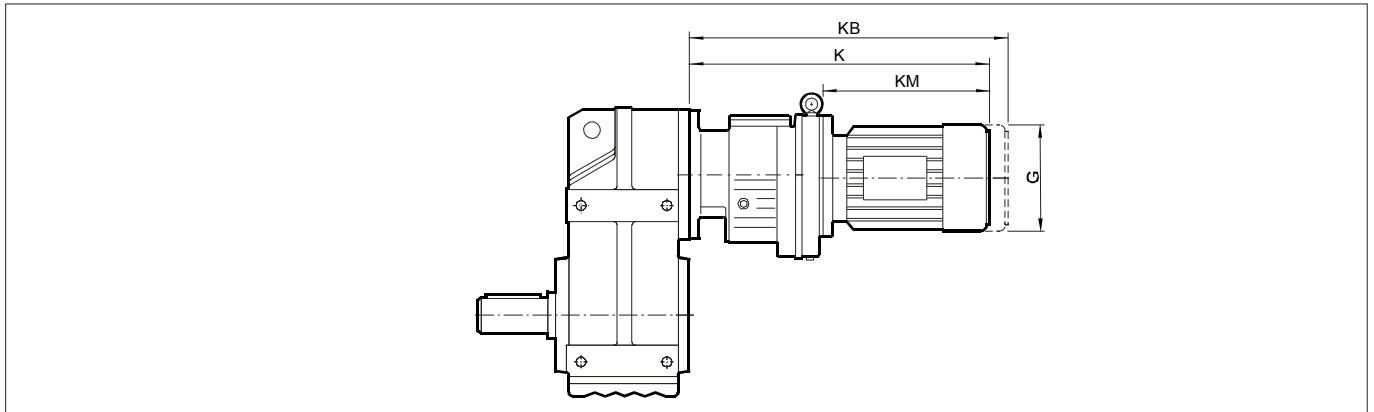

减速机规格 Gear unit size	电机规格 Motor frame	G	K	KB	KM
YF..37YR17 YF..47YR17	63..	132	338	395	163
	71..	145	339	403	164
	80..	145	389	453	214
YF..57YR37	63..	132	370	427	205
	71..	145	371	435	206
	80..	145	421	485	256
YF..67YR37	63..	132	362	419	205
	71..	145	363	427	206
	80..	145	413	477	256
YF..87YR57	63..	132	410	467	199
	71..	145	410	474	199
	80..	145	460	524	249
YF..97YR57	90..	197	480	565	269
	100L1	197	530	615	319
	100L2	197	560	645	349
	112M	221	588	673	341
	132S	221	630	710	390
YF..107YR77	63..	132	433	490	193
	71..	145	433	497	193
	80..	145	483	547	243
	90..	197	501	586	261
	100L1	197	551	636	311
	100L2	197	581	666	341
	112M	221	585	665	345
	132S	221	630	710	390
	132M	275	652	764	412
	160M	275	712	824	472

减速机规格 Gear unit size	电机规格 Motor frame	G	K	KB	KM
YF..127YR77	63..	132	425	482	193
	71..	145	425	489	193
	80..	145	475	539	243
	90..	197	493	578	261
	100L1	197	543	628	311
	100L2	197	573	658	341
	112M	221	577	657	345
	132S	221	622	702	390
	132M	275	644	756	472
	160M	275	704	816	472
YF..127YR87	90..	197	537	622	257
	100L1	197	587	672	307
	100L2	197	617	702	337
	112M	221	620	700	340
	132S	221	665	745	385
	132M	275	687	799	407
	160M	275	747	859	467
	160L	331	794	950	514
	180..	331	866	1022	586
	YF..157YR97	80..	145	556	620
90..		197	576	661	251
100L1		197	626	711	301
100L2		197	656	741	331
112M		221	660	740	335
132S		221	705	785	380
132M		275	727	839	402
160M		275	787	899	462
160L		331	834	990	509
180..		331	906	1062	581
200..	394	954	1110	629	



安装尺寸

Mounting Dimensions

联结法兰尺寸

Adapter dimensions

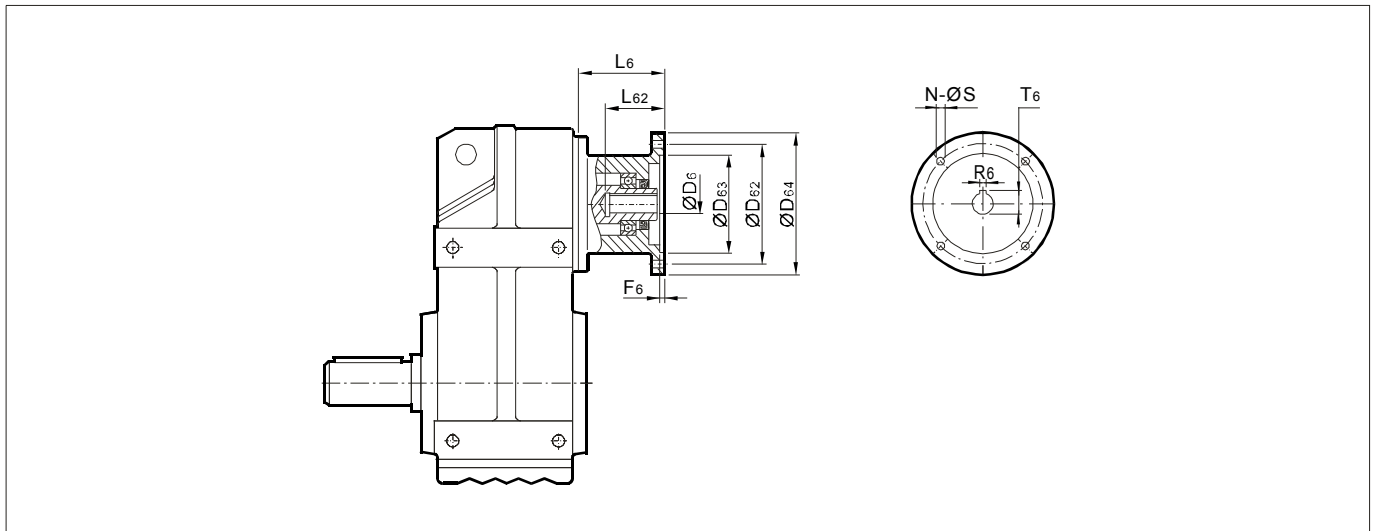

减速机型号 Gear unit size	法兰规格 Motor frame	D <sub>6</sub>	T <sub>6</sub>	R <sub>6</sub>	F <sub>6</sub>	L <sub>6</sub>	L <sub>62</sub>	D <sub>64</sub>	D <sub>62</sub>	D <sub>63</sub>	N	S
YF..37 YF..47	63B5	11	12.8	4	3.5	83	26	140	115	95	4	10
	71B5	14	16.3	5	3.5	83	33	160	130	110	4	10
	80B5	19	21.8	6	4.5	103	43	200	165	130	4	12
	90B5	24	27.3	8	4.5	103	53	200	165	130	4	12
YF..57 YF..67	63B5	11	12.8	4	3.5	83	26	140	115	95	4	10
	71B5	14	16.3	5	3.5	83	33	160	130	110	4	10
	80B5	19	21.8	6	4.5	103	43	200	165	130	4	12
	90B5	24	27.3	8	4.5	103	53	200	165	130	4	12
	100B5	28	31.3	8	5	110	63	250	215	180	4	15
	112B5	28	31.3	8	5	110	63	250	215	180	4	15
YF..77	63B5	11	12.8	4	3.5	83	26	140	115	95	4	10
	71B5	14	16.3	5	3.5	83	33	160	130	110	4	10
	80B5	19	21.8	6	4.5	103	43	200	165	130	4	12
	90B5	24	27.3	8	4.5	103	53	200	165	130	4	12
	100B5	28	31.3	8	5	110	63	250	215	180	4	15
	112B5	28	31.3	8	5	110	63	250	215	180	4	15
	132B5	38	41.3	10	5	133	85	300	265	230	4	15
YF..87	80B5	19	21.8	6	4.5	103	43	200	165	130	4	12
	90B5	24	27.3	8	4.5	103	53	200	165	130	4	12
	100B5	28	31.3	8	5	110	63	250	215	180	4	15
	112B5	28	31.3	8	5	110	63	250	215	180	4	15
	132B5	38	41.3	10	5	133	85	300	265	230	4	15
	160B5	42	45.3	12	6	171	115	350	300	250	4	19
	180B5	48	51.8	14	6	171	115	350	300	250	4	19
YF..97	100B5	28	31.3	8	5	110	63	250	215	180	4	15
	112B5	28	31.3	8	5	110	63	250	215	180	4	15
	132B5	38	41.3	10	5	133	85	300	265	230	4	15
	160B5	42	45.3	12	6	171	115	350	300	250	4	19
	180B5	48	51.8	14	6	171	115	350	300	250	4	19
	200B5	55	59.3	16	7	171	115	400	350	300	4	19
	225B5	60	64.4	18	7	215	145	450	400	350	8	19



安装尺寸

Mounting Dimensions

联结法兰尺寸

Adapter Dimensions

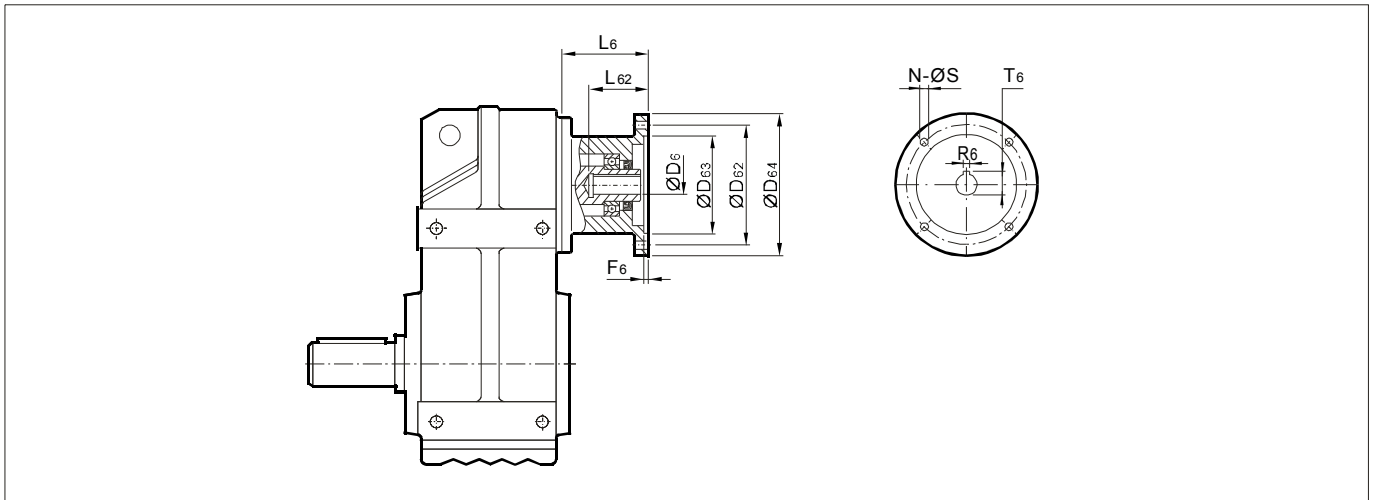

减速机型号 Gear unit size	法兰规格 Motorframe	D <sub>6</sub>	T <sub>6</sub>	R <sub>6</sub>	F <sub>6</sub>	L <sub>6</sub>	L <sub>62</sub>	D <sub>64</sub>	D <sub>62</sub>	D <sub>63</sub>	N	S
YF..107	100B5	28	31.3	8	5	110	63	250	215	180	4	15
	112B5	28	31.3	8	5	110	63	250	215	180	4	15
	132B5	38	41.3	10	5	133	85	300	265	230	4	15
	160B5	42	45.3	12	6	171	115	350	300	250	4	19
	180B5	48	51.8	14	6	171	115	350	300	250	4	19
	200B5	55	59.3	16	7	171	115	400	350	300	4	19
YF..127	225B5	60	64.4	18	7	215	145	450	400	350	8	19
	132B5	38	41.3	10	5	133	85	300	265	230	4	15
	160B5	42	45.3	12	6	171	115	350	300	250	4	19
	180B5	48	51.8	14	6	171	115	350	300	250	4	19
	200B5	55	59.3	16	7	171	115	400	350	300	4	19
	225B5	60	64.4	18	7	215	145	450	400	350	8	19
YF..157	250B5	65	69.4	18	7	215	145	550	500	450	8	19
	280B5	75	79.9	20	7	215	145	550	500	450	8	19
	132B5	38	41.3	10	5	133	85	300	265	230	4	15
	160B5	42	45.3	12	6	171	115	350	300	250	4	19
	180B5	48	51.8	14	6	171	115	350	300	250	4	19
	200B5	55	59.3	16	7	171	115	400	350	300	4	19

注意!

- 1 选用侧面安装减速机时, 尺寸 $\varnothing D_{64}$ 可能会超过侧面安装面, 请注意校核。
- 2 适配电机参照IEC B5法兰规格, 其它未注尺寸请参考相关机型号。

Attention!

- 1 Dimension  $\varnothing D_{64}$  may protrude past foot mounting surface if selecting foot-mounted type.
- 2 the motor flange follow IEC B5 type, dimensions is not indicated, please refer to correlative gear unit size



安装尺寸

Mounting Dimensions

输入轴尺寸

Input Shaft Dimensions

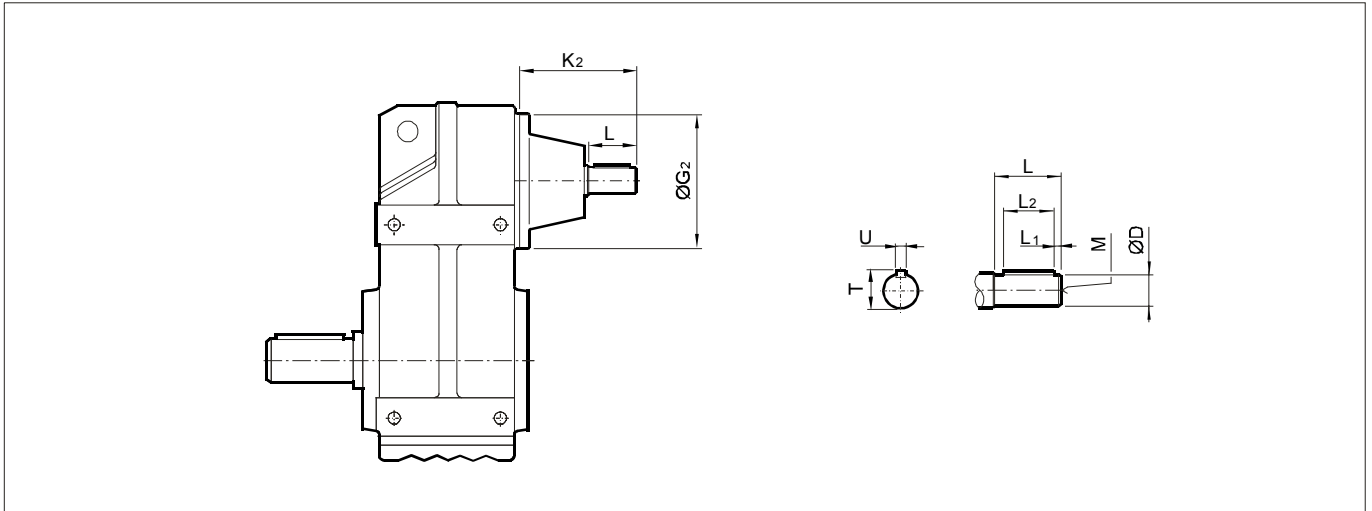

减速机型号 Gear unit size	D	G <sub>2</sub>	K <sub>2</sub>	L	M	L <sub>1</sub>	L <sub>2</sub>	T	U
<b>YF..37S</b>	16k6	120	115	40	M5	4	32	18	5
<b>YF..47S</b>	19k6	160	120	40	M6	4	32	21.5	6
<b>YF..57S</b>	19k6	160	120	40	M6	4	32	21.5	6
<b>YF..67S</b>	19k6	160	120	40	M6	4	32	21.5	6
<b>YF..77S</b>	24k6	200	140	50	M8	5	40	27	8
<b>YF..87S</b>	28k6	250	180	60	M10	5	50	31	8
<b>YF..97S</b>	38k6	300	220	80	M12	5	70	41	10
<b>YF..107S</b>	42k6	350	270	110	M16	10	90	45	12
<b>YF..127S</b>	55m6	450	297	110	M20	10	90	59	16
<b>YF..157S</b>	70m6	550	374	140	M20	15	110	74.5	20

注意!

其它未注尺寸请参考相关机型号.

**Attention!**

Dimensions is not indicated, please refer to correlative gear unit size

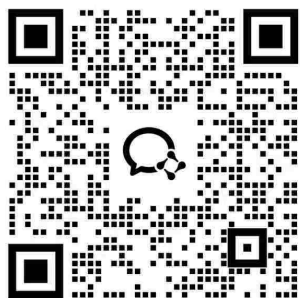

添加企业微信



微信选型小程序